



JIS University

Syllabus/ Curriculum

Regulation: 2016 (R-16)

Program Name:

B.Tech in Computer Science & Engineering

Department of

Computer Science & Engineering

**Department of Computer Science and
Engineering**

*Curriculum Structure & Syllabus
of
1st to 8th Semester under
to be effective from 2016-2017*

Curriculum for BTech in Computer Science and Engineering

1stSemester							
Sl No	Paper Code	Theory	Contact Hours /Week				Credit Points
			L	T	P	Total	
1	M 101	Mathematics -I	3	1	0	4	4
2	CH 101/ PH 101	Chemistry (Gr. A) / Physics - I(Gr. B)	3	1	0	4	4
3	EE 101/ EC 101	Basic Electrical Engineering (Gr. A) / Basic Electronics Engineering (Gr. B)	3	1	0	4	4
4	HU 101	Communicative English	2	0	0	2	2
5	ME 101	Engineering Mechanics	3	1	0	4	4
Total of Theory						18	18
A. PRACTICAL							
6	HU191	Lang. Lab. and Seminar Presentation	0	0	2	2	1
7	CH 191/ PH191	Chemistry Lab (Gr. A) / Physics -I Lab(Gr. B)	0	0	3	3	2
8	EE 191/ EC 191	Basic Electrical Engineering Lab (Gr. A) /Basic Electronics Engineering Lab(Gr. B)	0	0	3	3	2
9	ME 191/ ME 192	Engg Drawing & Graphics(Gr A)/ Workshop Practice (Gr-B)	0	0	3	3	2
B. SESSIONAL							
10	XC181	Extra Curricular Activity (NSS/ NCC)	0	0	2	2	1
Total of Practical &Sessional						13	08

2 nd Semester							
Sl No	Paper Code	Theory	Contact Hours/Week				Credit Points
			L	T	P	Total	
1	M 201	Mathematics -II	3	1	0	4	4
2	CH 201/ PH 201	Chemistry (Gr. B) / Physics - I(Gr. A)	3	1	0	4	4
3	EE 201/ EC 201	Basic Electrical Engineering (Gr. B) / Basic Electronics Engineering (Gr. A)	3	1	0	4	4
4	CS 201	Computer Fundamentals & Principle of Computer Programming	3	1	0	4	4
5	ME 201	Engineering Thermodynamics & Fluid Mechanics	3	1	0	4	4
Total of Theory						20	20
B. PRACTICAL							
6	CS291	Computer Fundamentals & Principle of Computer Programming Lab	0	0	3	3	2
7	CH 291/ PH291	Chemistry Lab (Gr. B) / Physics -I Lab(Gr. A)	0	0	3	3	2
8	EE 291/ EC 291	Basic Electrical Engineering Lab (Gr. B) /Basic Electronics Engineering Lab(Gr. A)	0	0	3	3	2
9	ME 291/ ME 292	Engg Drawing & Graphics(Gr B)/ Workshop Practice (Gr-A)	0	0	3	3	2
Total of Practical						12	08
C.SESSIONAL							
10	MC 281	Soft Skill Development	0	0	2	2	0

3 rd Semester								
SL No	Type	Code	A. THEORY	Contact hours				Cr. Points
				L	T	P	Total	
1	BS	M(CSE)301	Mathematics-III	3	1	0	4	4
2	BS	PH301	Physics-II	3	0	0	3	3
3	ES	EE(CSE)301	Circuit Theory and Network	3	0	0	3	3
4	PC	CS301	Data Structures	3	0	0	3	3
5	PC	CS302	Digital Electronics and Computer Organization	3	0	0	3	3
Total Theory							16	16
B. PRACTICAL								
6	BS	PH391	Physics-II Lab	0	0	3	3	2
7	ES	EE(CSE)391	Circuit Theory and Network Lab	0	0	3	3	2
8	PC	CS391	Data Structures Lab	0	0	3	3	2
9	PC	CS392	Digital Electronics and Computer Organization Lab	0	0	3	3	2
Total Practical							12	8
C. SESSIONAL								
10	HU	HU381	Technical Report writing and Language Practice Lab	0	0	2	2	1
Total							30	25

4 th Semester								
SL No	Type	Code	A. THEORY	Contact hours				Cr. Points
				L	T	P	Total	
1	BS	M(CSE)401	Numerical Methods and Statistics	3	0	0	3	3
2	HS	HU401	Environmental science	2	0	0	2	2
3	PC	CS401	Computer Architecture	3	0	0	3	3
4	PC	CS402	Design and Analysis of Algorithms	3	0	0	3	3
5	PC	CS 403	Formal Language And Automata Theory	3	0	0	3	3
Total Theory							14	14
			<u>B. PRACTICAL</u>					
6	BS	M(CSE)491	Numerical Methods and Statistics Lab	0	0	3	3	2
7	PC	CS491	Computer Architecture Lab	0	0	3	3	2
8	PC	CS492	Algorithms Lab	0	0	3	3	2
9	PC	CS493	Programming with C++ Lab	1	0	2	3	2
Total Practical							12	8
			<u>C. MANDATORY COURSES</u>					
10	MC	MC 481	Technical Communication & Soft Skills	0	0	3	3	2 Unit
Total							29	22

<u>SL No</u>			5 th Semester					Cr. Points
			Contact hours					
	<u>Type</u>	<u>Code</u>	<u>A. THEORY</u>	L	T	P	Total	
1	PC	CS501	Computer Graphics	3	0	0	3	3
2	PC	CS502	Operating System	3	0	0	3	3
3	HS	HU 503	Economics for Engineers	2	0	0	2	2
4	PC	CS503	Data Base Management System	3	0	0	3	3
5	FE	CS(IT)504A	Object Oriented Programming using Java	3	0	0	3	3
		CS(IT)504B	Multimedia Technology					
		CS(ECE)504C	Communication Engineering					
6	PE	CS505A	Operations Research	3	0	0	3	3
		CS505A	Computational Geometry					
		CS505A	Digital Signal Processing					
Total Theory							17	17
			<u>B. PRACTICAL</u>					
7	PC	CS591	Computer Graphics Lab	0	0	3	3	2
8	PC	CS592	Operating System Lab	0	0	3	3	2
9	PC	CS 593	Data Base Management System Lab	0	0	3	3	2
10	FE	CS(IT)594A	Object Oriented Programming Lab	0	0	3	3	2
		CS(IT)594B	Multimedia Technology Lab					
		CS(ECE)594C	Communication Engineering Lab					
Total Practical							12	8
			<u>C. MANDATORY COURSES</u>					
11	MC	MC581	General Aptitude /Foreign Language	0	0	3	3	2 Unit
Total							32	25

6TH SEMESTER								
SL No	Type	Code	A. THEORY	Contact hours				Cr. Points
				L	T	P	Total	
1	PC	CS601	Computer Network	3	0	0	3	3
2	PC	CS602	Microprocessor and Microcontroller	3	0	0	3	3
3	PC	CS603	Software Engineering	3	0	0	3	3
4	PE	CS604A	Compiler Design	3	0	0	3	3
		CS604B	Robotics					
		CS604C	Simulation and modeling					
5	FE	IT(CSE)605A	Pattern Recognition	3	0	0	3	3
		IT(CSE)605B	Distributed Operating System					
		IT(CSE)605C	Distributed Database					
		IT(CSE)605D	Computer Vision					
6	FE	IT(CSE)606A	Data Warehousing and Data Mining	3	0	0	3	3
		IT(CSE)606B	Digital Image Processing					
		IT(CSE)606C	E-commerce and ERP					
Total Theory							18	18
			<u>B. PRACTICAL</u>					
7	PC	CS691	Computer Network Lab	0	0	3	3	2
8	PC	CS692	Microprocessor and Microcontroller Lab	0	0	3	3	2
9	PC	CS693	Software Engineering Lab	0	0	3	3	2
10		CS682	Mini Project	0	0	3	3	2
Total Practical							12	8
<u>C. SESSIONAL</u>								
10		CS681	Group Discussion and Seminar	0	0	3	3	2
Total							33	28

7TH SEMESTER								
				Contact hours				Cr. Points
<u>SL No</u>	<u>Type</u>	<u>Code</u>	<u>A. THEORY</u>	L	T	P	Total	
1	PC	CS701	Artificial Intelligence	3	0	0	3	3
2	HS	HU702	Values & Ethics in Profession	2	0	0	2	2
3	PE	CS702A	Soft Computing	3	0	0	3	3
		CS702B	Natural Language Processing					
		CS702C	Web technology					
4	PE	CS703A	Cloud Computing	3	0	0	3	3
		CS703B	Data Analytics					
		CS703C	Sensor Network and IOT					
5	PE	CS704A	Distributed Algorithms	3	0	0	3	3
		CS704B	Bio-informatics					
		CS704C	Cryptography and Network Security					
Total Theory							14	14
<u>B. PRACTICAL</u>								
6	PC	CS791	Artificial Intelligence Lab	0	0	3	3	2
7	PE	CS792A	Soft Computing Lab	0	0	3	3	2
		CS792B	Natural Language Processing Lab					
		CS792C	Web Technology Lab					
8		CS795	Project-1	0	0	3	3	2
Total Practical							9	6
<u>C. SESSIONAL</u>								
9		CS781	Industrial Training	0	0	0	0	2
Total Sessional								
<u>D. MANDATORY COURSES</u>								
10	MC	MC781	Technical Skill Development	0	0	3	3	2Unit
Total							26	22

8TH SEMESTER								
				Contact hours				Cr. Points
8th Semester				L	T	P	Total	
<u>SL No</u>	<u>Type</u>	<u>Code</u>	<u>A. THEORY</u>					
1	HS	HU804	Principles of Management	2	0	0	2	2
2	PE	CS801A	Mobile Computing	3	0	0	3	3
		CS801B	Human computer Interaction					
		CS801C	Cyber Law and Security Policy					
		CS801D	VLSI Design					
3	PE	CS802A	Parallel Computing	3	0	0	3	3
		CS802B	Machine Learning					
		CS802C	Real Time Operating System and Embedded System					
		CS802D	Advanced Computer Architecture					
Total Theory							8	8
<u>B. PRACTICAL</u>								
4	PC	CS891	Design lab	0	0	3	3	2
5		CS892	Project 2	0	0	12	9	6
6		CS893	Seminar Presentation	0	0	3	3	2
Total Practical							15	10
<u>C. SESSIONAL</u>								
7		CS881	Grand Viva	0	0	0	0	4
Total							26	22
Grand Total								198

Department of Computer Science and
Engineering

Curriculum Structure

& Syllabus

(2016-2017)

(Autonomy)

of

1st Semester

Curriculum for BTech in Computer Science and Engineering

1stSemester							
Sl No	Paper Code	Theory	Contact Hours /Week				Credit Points
			L	T	P	Total	
1	M 101	Mathematics -I	3	1	0	4	4
2	CH 101/ PH 101	Chemistry (Gr. A) / Physics - I(Gr. B)	3	1	0	4	4
3	EE 101/ EC 101	Basic Electrical Engineering (Gr. A) / Basic Electronics Engineering (Gr. B)	3	1	0	4	4
4	HU 101	Communicative English	2	0	0	2	2
5	ME 101	Engineering Mechanics	3	1	0	4	4
Total of Theory						18	18
A. PRACTICAL							
6	HU191	Lang. Lab. and Seminar Presentation	0	0	2	2	1
7	CH 191/ PH191	Chemistry Lab (Gr. A) / Physics -I Lab(Gr. B)	0	0	3	3	2
8	EE 191/ EC 191	Basic Electrical Engineering Lab (Gr. A) /Basic Electronics Engineering Lab(Gr. B)	0	0	3	3	2
9	ME 191/ ME 192	Engg Drawing & Graphics(Gr A)/ Workshop Practice (Gr-B)	0	0	3	3	2
B. SESSIONAL							
10	XC181	Extra Curricular Activity (NSS/ NCC)	0	0	2	2	1
Total of Practical &Sessional						13	08

Syllabus:

Theory

Paper Name: Mathematics –I

Paper Code: M101

Total Contact Hours: 40

Credit: 4

Prerequisite: Any introductory course on matrix algebra, calculus, geometry.

Course Objective: The purpose of this course is to provide fundamental concepts matrix algebra, Calculus of Single and Several Variables and Vector Analysis.

Course outcome:

On successful completion of the learning sessions of the course, the learner will be able to:

M 101.1: Recall the distinctive characteristics of Matrix Algebra, Calculus of Single and Several Variables and Vector Analysis.

M 101.2: Understand the theoretical concept of Matrix Algebra, Calculus of Single and Several Variables and Vector Analysis.

M 101.3: Apply the principles of Matrix Algebra, Calculus of Single and Several Variables and Vector Analysis to solve various problems.

Course contents:

MODULE I [10L]

Matrix Algebra: Elementary row and column operations on a matrix, Rank of matrix, Normal form, Inverse of a matrix using elementary operations, Consistency and solutions of systems of linear equations using elementary operations, Linear dependence and independence of vectors, Concept & Properties of different matrices (unitary, orthogonal, symmetric, skew-symmetric, hermitian, skew-hermitian), Eigen values and Eigen vectors of a square matrix (of order 2 or 3), Characteristic polynomials, Caley-Hamilton theorem and its applications, Reduction to diagonal form (upto 3rd order).

MODULE II [10L]

Calculus-I (Functions of single variable): Rolle's theorem, Mean value theorem- Lagrange & Cauchy, Taylor's and Maclaurin's theorems, Expansion of simple functions by Taylor's and Maclaurin's Theorems, Fundamental theorem of integral calculus, Evaluation of plane areas, volume and surface area of a solid of revolution and lengths, Convergence of Improper integrals, Beta and Gamma Integrals - Elementary properties and the Inter relations.

MODULE III [12L]

Calculus-II (Functions of several variables): Introduction to functions of several variables with examples, Knowledge of limit and continuity, Partial derivatives, Total Differentiation, Derivatives of composite and implicit functions, Euler's theorem on homogeneous functions, Chain rule, Maxima and

minima of functions of two variables – Lagrange’s method of Multipliers, Change of variables-Jacobians (up to three variables), Double and triple integrals.

MODULE IV [8L]

Vector Calculus: Scalar and vector triple products, Scalar and Vector fields, Vector Differentiation, Level surfaces, Directional derivative, Gradient of scalar field, Divergence and Curl of a vector field and their physical significance, Line, surface and volume integrals, Green’s theorem in plane, Gauss Divergence theorem, Stokes’ theorem, Applications related to Engineering problems.

Text Books:

1. E. Kreyszig, Advanced engineering mathematics (8th Edition), John Wiley, 1999.
2. B.S.Grewal, Higher Engineering Mathematics, Khanna Publications, 2009.
3. R.K.Jain and S.R.K.Iyengar, Advanced Engineering Mathematics, Narosa Pub. House, 2008.
4. H. Anton, Elementary linear algebra with applications (8th Edition), John Wiley, 1995.
5. G. Strang, Linear algebra and its applications (4th Edition), Thomson, 2006.

ReferenceBooks:

6. S. Kumaresan, Linear algebra - A Geometric approach, Prentice Hall of India, 2000.
7. M. Apostol, Calculus, Volumes 1 and 2 (2nd Edition), Wiley Eastern, 1980.
8. TG. B. Thomas and R. L. Finney, Calculus and Analytic Geometry (9th Edition), ISE Reprint, Addison-Wesley, 1998.
9. Hughes-Hallett et al., Calculus - Single and Multivariable (3rd Edition), John-Wiley and Sons, 2003.
10. J. Stewart, Calculus (5th Edition), Thomson, 2003.
11. J. Bird, Higher Engineering Mathematics (4th Edition, 1st India Reprint), Elsevier,2006.
12. L.Rade and B.Westergen, Mathematics Handbook: for Science and Engineering (5th edition, 1st Indian Edition), Springer, 2009.
13. [Murray R Spiegel](#) and [Seymour Lipschutz](#), Schaum's Outline of Vector Analysis.
14. [Richard Bronson](#), Schaum's Outline of Matrix Operations.

CO-PO mapping:

CO \ PO	PO1	PO2	PO3	PO4	PO5	PO6	PO7	PO8	PO9	P10	P11	P12
M 101.1	3	2	-	-	-	-	-	-	-	-	-	1
M 101.2	3	2	-	-	-	-	-	-	-	-	-	1
M 101.3	3	2	2	-	-	-	-	-	-	-	-	1

FOR GROUP A: EE, ECE, EIE/AEIE, BME

Paper Name: Chemistry
Paper Code: CH 101
Total Contact Hours: 40
Credit: 4

Pre requisites: 10+2 science with chemistry

Course Objective

Understanding of the fundamental theories and applications of thermodynamics, electrochemical principles in modern electrochemical cells and to get an insight into electronic structure of crystals and nanomaterials. Learning about the Synthesis, properties and applications of polymers, fuels and alternative energy sources & their significance in petrochemical industries. Analyzing water quality for its various parameters & its significance in industries.

Course Outcome

CH101.1: Able to apply fundamental concepts of thermodynamics in different engineering applications.

CH101.2: Able to analyze & design simple and technologically advanced electrical and energy storage devices.

CH101.3: Able to synthesize nanomaterials, composites, polymers.

CH101.4: Able to apply the basic concept of Organic Chemistry and knowledge of chemical reactions to industries, and technical fields.

CH101.5: Able to apply the knowledge of different fuels and corrosion to different industries

CH101.6: Able to analyse water quality parameter for its various parameters & its significance in industries.

Course contents

Module 1 [8L]

Chemical Thermodynamics –I

1.1 Concept of Thermodynamic system: Definition with example of diathermal wall, adiabatic wall, isolated system, closed system, open system, extensive property, intensive property.

Introduction to first law of thermodynamics: Different statements, mathematical form.

Internal energy: Definition, Example, Characteristics, Physical significance, Mathematical expression for change in internal Energy, Expression for change in internal energy for ideal gas.

2L

1.2 Enthalpy: Definition, Characteristics, Physical significance, Mathematical expression for change in Enthalpy, Expression for change in enthalpy for ideal gas.

Heat Capacity: Definition, Classification of Heat Capacity (Cp and CV): Definition and General expression of Cp - CV. Expression of Cp - CV for ideal gas.

Reversible and Irreversible processes: Definition, Work done in Isothermal Reversible and Isothermal Irreversible process for Ideal gas, Adiabatic changes: Work done in adiabatic process, Interrelation between thermodynamic parameters (P, V and T), slope of P-V curve in adiabatic and isothermal process.

Application of first law of thermodynamics to chemical processes: exothermic, endothermic processes, law of Lavoisier and Laplace, Hess's law of constant heat summation.

3L

1.3 2nd law of thermodynamics: Statement, Mathematical form of 2nd law of thermodynamics (Carnot cycle). Joule Thomson and throttling processes; Joule Thomson coefficient for Ideal gas, Concept of inversion temperature (brief).

Evaluation of entropy: characteristics and expression, physical significance. Work function and free energy: Definition, characteristics, physical significance, mathematical expression of ΔA and ΔG for ideal gas, standard free energy and chemical potential, Condition of spontaneity and equilibrium reaction. **3L**

Module 2 [7L]

2.1 Reaction Dynamics

Reaction laws: rate and order; molecularity; zero and first order kinetics, second order kinetics (same reactant concentration), Pseudounimolecular reaction, Arrhenius equation. **3L**

Mechanism and theories of reaction rates (Content beyond the syllabus)

2.2 Solid state Chemistry

Introduction to stoichiometric defects (Schottky & Frenkel) and non – stoichiometric defects (Metal excess and metal deficiency).

Role of silicon and germanium in the field of semiconductor, n-type, p-type semiconductor, photo voltaic cell, fabrication of integrated circuits. **4L**

Module 3 [8L]

Electrochemistry

3.1 Conductance

Conductance of electrolytic solutions, specific conductance, equivalent conductance, molar conductance and ion conductance, effect of temperature and concentration (Strong and Weak electrolyte). **1L**

3.2 Electrochemical cell

Cell EMF and its Thermodynamic derivation of the EMF of a Galvanic cell (Nernst equation), single electrode potentials, hydrogen half cell, calomel half cell (representation, cell reaction, expression of potential, Discussion, Application). **3L**

3.3 Concept of battery

Battery and Commercial electrochemical cell: Dry cell, acid storage cell, alkaline storage cell, fuel cell (construction, representation, cell reaction, expression of potential, discussion, application). **2L**

3.4 Corrosion and its control

Introduction, cause and effect of corrosion, types of corrosion: dry, wet and other: Electrochemical corrosion, galvanic corrosion, passivation and protective measure. **2L**

Module 4 [12L]

4.1 Structure and reactivity of Organic molecule

Electronegativity, electron affinity, hybridisation, Inductive effect, resonance, hyperconjugation, electromeric effect, carbocation, carbanion and free radicals. Brief study of some addition, eliminations and substitution reactions. **3L**

4.2 Polymers

Concepts, classifications and industrial applications. Polymer molecular weight (number avg. weight avg.: Theory and mathematical expression only), Poly dispersity index (PDI).

Polymerization processes: addition and condensation polymerization (mechanism not required), degree of polymerization, Copolymerization, stereo-regularity of polymer, crystallinity (concept of T_m) and amorphicity (Concept of T_g) of polymer.

Preparation, structure and use of some common polymers: plastic (HDPE, LDPE, PVC, PP, PMMA, Polyester, PTFE, Bakelite), rubber (natural rubber, SBR), fibre (nylon 6, nylon 6,6), Vulcanization of rubber, Conducting polymers and bio-polymers. **7L**

4.3 Nano material

Basic principles of nano science and technology, classification, preparation, properties and application of nano material. **2L**

Module 5 [5L]

5.1 Industrial Chemistry

Fuels

Solid Fuel: Coal, Classification of coal, constituents of coal, carbonization of coal (HTC and LTC), Proximate analysis of coal, Calorific value.

Liquid fuel: Petroleum, classification of petroleum, Refining, Octane number, Cetane number, Aviation Fuel (Aviation Gasoline, Jet Gasoline), Biodiesel.

Gaseous fuels: Natural gas, water gas, Coal gas, bio gas, CNG, LPG **3L**

5.2 Water

Introduction, source of water, water quality parameter, specification for drinking water (BIS and WHO standards), Chlorination of Water, Types of hardness- Units, Brief Softening methods.

2L

Short overview of water treatment plants(Content beyond the syllabus)

Reference Books

1. Engineering Chemistry: Bandyopadhyay and Hazra
2. Physical Chemistry: P.C. Rakshit
3. Organic Chemistry: Finar, vol-1
4. Engineering Chemistry: B.Sivasankar, Tata Mc Graw Hill, 2008
5. A Text book of Engineering Chemistry: S.S.Dara, 10th Edition, S.Chand & Company Ltd., New Delhi, 2003.
6. Engineering Chemistry Simplified: S. Nandi and R. Bhattacharyya, Chayya Prakashani Pvt. Ltd.

CO-PO mapping:

	PO1	PO2	PO3	PO4	PO5	PO6	PO7	PO8	PO9	P10	P11	P12
CH101.1	3	1	-	-	-	-	-	-	-	-	-	-
CH101.2	3	2	1	-	-	-	-	-	-	-	-	-
CH101.3	-	-	2	-	2	-	-	-	-	-	-	1
CH101.4	2	-	1	-	2	-	-	-	-	-	-	-
CH101.5	2	-	-	-	-	-	2	-	-	-	-	1
CH101.6	-	-	2	-	-	-	1	-	-	-	-	-

FOR GROUP B: CSE, IT, FT, ME, CE

Paper Name: Physics -I
Paper Code: PH 101
Total Contact Hours: 41
Credit: 4

Pre requisites: Knowledge of Physics upto 12th standard.

Course Objective:

The aim of courses in Physics is to provide an adequate exposure and develop insight about the basic physics principles along with the possible applications. The acquaintance of basic principles of physics would help engineers to understand the tools and techniques used in the industry and provide the necessary foundations for inculcating innovative approaches. It can also create awareness of the vital role played by science and engineering in the development of new technologies. It also gives necessary exposure to the practical aspects, which is an essential component for learning sciences.

Course Outcome:

At the end of the course students' should have the

PH 101.1 : Ability to state and recall <ul style="list-style-type: none">➤ De-Broglie hypothesis, and Heisenberg's Uncertainty Principle➤ Amplitude and Velocity Resonance➤ Malus's Law, Brewster's Law➤ Characteristics of LASER light	PO1 Or GA1
PH 101.2 : Ability to understand and explain <ul style="list-style-type: none">➤ Polarizer and analyzer➤ basic principles and different types of LASER and Optical Fibre➤ structure of solids, Miller indices➤ theory of Matter Wave, equation of motion of Matter Wave➤ wave function and its role in representing wave nature of matter	PO2 Or GA2
PH 101. 3:Ability to apply the knowledge of <ul style="list-style-type: none">➤ mechanical vibration in electrical circuits	PO3 Or

<ul style="list-style-type: none"> ➤ superposition principle in Newton's ring phenomenon, diffraction phenomenon ➤ quantum nature of e.m. waves for production of laser ➤ total internal reflection in transmitting light through optical fibres ➤ x-ray diffraction in crystal structure ➤ probability interpretation in Heisenberg's uncertainty principle 	GA3
<p>PH 101.4:Ability to analyze</p> <ul style="list-style-type: none"> ➤ grating as many slit system ➤ role of Q factor in a resonating circuit, conditions of different types of resonance ➤ minimum requirements for lasing action ➤ importance of light as a carrier of information ➤ the failures of classical physics in microscopic situation and need of quantum physics ➤ Einstein's A, B coefficient and predict the wavelength domain of Lasing action ➤ Requirement of Miller indices for describing crystallographic planes 	PO2 Or GA2
<p>PH 101.5:Ability to evaluate / justify / compare</p> <ul style="list-style-type: none"> ➤ X-ray production process is inverse of the process of Photoelectric Effect. ➤ different crystallographic structures according to their Co-ordination number and packing factors ➤ the outcome of Photo-electric effect, Compton effect and Davission-Germer experiment to justify wave-particle duality of matter 	PO12 Or GA12

Course contents

Module 1 (8L):-

Oscillations

1.1 Simple harmonic motion: Concepts with examples, Superposition of SHMs in two mutually perpendicular directions:Lissajous' figures, Engineering Applications and related Numerical problems
2L

1.2 Damped vibration: Differential equation and its solution, Logarithmic decrement, quality factor, Engineering Applications and related Numerical problems. 3L

1.3 Forced vibration: Differential equation and solution, Amplitude and Velocity resonance, Sharpness of resonance, relevant applications including LCR circuits, Numerical problems 3L

Module 2 (10L):-

Classical Optics:

2.1 Interference of light: Wave nature of light (Huygen's principle), Conditions of sustained interference double slit as an example; qualitative idea of spatial and temporal coherence, conservation of energy and intensity distribution; Newton's ring (qualitative descriptions of working principles and procedures-no deduction required). Engineering applications, Numerical Problems. 3L

Fresnel's biprism (beyond the syllabus). 1L(ext)

2.2 Diffraction of light: Fresnel and Fraunhofer class, Fraunhofer diffraction for plane transmission grating (elementary treatment of intensity distribution for N-slits), single slit and double slits as examples, missing order, Rayleigh criterion, resolving power of grating and microscope (Definition and formula; no deduction required). Engineering Applications, Numerical Problems. 4L

2.3 Polarization: Definition, plane of polarization, plane of vibration, Malus law, fundamental concepts of plane, circular and elliptical polarizations (only qualitative idea) with examples, Brewster's law, Double refraction: ordinary and extraordinary rays, Nicol's prism, Engineering applications, Numerical problems. 3L

Module 3 (9L):-

Quantum Physics:

3.1 Quantum Theory: Inadequacy of classical physics; Planck's quantum hypothesis-Qualitative (without deductions), particle concept of electromagnetic wave (example: photoelectric and Compton effect; qualitative discussions only), wave particle duality; phase velocity and group velocity; de Broglie wave; Davisson and Germer experiment. 4L

3.2 Quantum Mechanics 1: Concept of wave function, Physical significance of wave function, Probability interpretation; wave function normalization condition and its simple numerical applications; uncertainty principle-applications, Schrödinger equation (no mathematical derivation). 4L

Module 4 (6L):

X-ray & Crystallography

4.1 X-rays – Origin of Characteristic and Continuous X-ray, Bragg's law (No derivation), Determination of lattice constant, Applications, Numerical problems. 2L

4.2 Elementary ideas of crystal structure - lattice, basis, unit cell, Fundamental types of lattices – Bravais lattice, Simple cubic, fcc and bcc, **hcp** lattices, (use of models in the class during teaching is desirable) Miller indices and miller planes, Co-ordination number and Atomic packing factor, Applications, Numerical problems. 4L

Module 5 (8L):

Modern Optics-I:

5.1 Laser: Concepts of various emission and absorption process, working principle of laser, metastable state, Population Inversion, condition necessary for active laser action, optical resonator, ruby laser, He-Ne laser, **semiconductor laser**, Einstein A and B coefficients and equations, industrial and medical applications of laser. 5L

5.2 Fibre optics and Applications: Principle and propagation of light in optical fibres- Numerical aperture and Acceptance angle, V number, Types of optical fibres (material, refractive index, mode), Losses in optical fibre- attenuation, dispersion, bending, Numerical problems. 3L

Recommended Text Books for Physics I (PH101//201):

Oscillations:

1. Classical Mechanics- J. C. Upadhyay (Himalya Publishers)
2. Classical Mechanics-Shrivastav
3. Classical Mechanics-Takwal & Puranik (TMH)
4. Sound-N. K. Bajaj (TMH)
5. Advanced Acoustics-D. P. Roy Chowdhury (Chayan Publisher)
6. Principles of Acoustics-B.Ghosh (Sridhar Publisher)
7. A text book of sound-M. Ghosh (S. Chand publishers)
8. Electricity Magnetism-Chattopadhyay & Rakshit (New Central Book Agency)
9. A text book of Light- K.G. Mazumder & B.Ghoshs, (Book& Allied Publisher)
10. R.P. Singh (Physics of Oscillations and Waves)
11. A.B. Gupta (College Physics Vol. II)
12. Chattopadhyaya and Rakshit(Vibration, Waves and Acoustics)

Classical Optics & Modern Optics-I:

13. A text book of Light- K.G. Mazumder & B.Ghoshs (Book& Allied Publisher)
14. A text book of Light-Brijlal & Subhramaniam, (S. Chand publishers)
15. Modern Optics-A. B. Gupta (Book& Allied Publisher)
16. Optics-Ajay Ghatak (TMH)
17. Optics-Hecht
18. Optics-R. Kar, Books Applied Publishers
19. Möler(Physical Optics)
20. E. Hecht (Optics)
21. E. Hecht (Schaum Series)
22. F.A. Jenkins and H.E White
23. C.R. Dasgupta (Degree Physics Vol 3)

Quantum Physics

24. Introduction to Quantum Mechanics-S. N. Ghoshal (Calcutta Book House)
25. Quantum Mechanics-Bagde Singh (S. Chand Publishers)
26. Perspective of Quantum Mechanics-S. P. Kuilla (New Central Book Agency)
27. Quantum Mechanics-Binayak Datta Roy (S. Chand Publishers)
28. Quantum Mechanics-Bransden (Pearson Education Ltd.)
29. Perspective of Modern Physics-A. Beiser (TMH)
30. Eisberg & Resnick is published by Wiley India
31. A.K. Ghatak and S Lokenathan
32. E.E. Anderson (Modern Physics)
33. Haliday, Resnick & Krane : Physics Volume 2 is Published by Wiley India
34. Binayak Dutta Roy [Elements of Quantum Mechanics]

X-ray & Crystallography

35. Solid state physics-Puri & Babbar (S. Chand publishers)
36. Materials Science & Engineering-Kakani Kakani
37. Solid state physics- S. O. Pillai
38. Introduction to solid state physics-Kittel (TMH)
39. Solid State Physics and Electronics-A. B. Gupta, Nurul Islam (Book & Allied Publisher)
40. S.O. Pillai (a. Solid state physics b. Problem in Solid state physics)

General Reference:

1. Refresher courses in physics (Vol. 1, Vol. 2 & Vol. 3)-C. L. Arora (S. Chand Publishers)
2. Basic Engineering Physics-Amal Chakraborty (Chaya Prakashani Pvt. Ltd.)
3. Basic Engineering Physics-I -Sujoy Bhattacharya, Saumen Paul (TMH)
4. Engineering Physics Vol: 1-Sudipto Roy, Tanushri Ghosh, Dibyendu Biswas (S. Chand).
5. Engineering Physics Vol:1-S. P. Kuila (New Central)
4. University Physics-Sears & Zemansky (Addison-Wesley)
- 5.B. Dutta Roy (Basic Physics)
6. R.K. Kar (Engineering Physics)
- 7.Mani and Meheta (Modern Physics)
8. Arthur Baiser (Perspective & Concept of Modern Physics)

CO-PO Mapping:

CO	PO1	PO2	PO3	PO4	PO5	PO6	PO7	PO8	PO9	PO10	PO11	PO12
PH 101.1	1											
PH 101.2		2										
PH 101.3	3											
PH 101.4		1										
PH 101.5												1

FOR GROUP A: EE, ECE, EIE/AEIE, BME

Paper Name: Basic Electrical Engineering

Paper Code: EE101

Total Contact Hours: 41

Credit: 4

Pre requisite: Basic 12st standard Physics and Mathematics

Course Objective:

Basic electrical engineering is an introductory course in electrical engineering. Students are introduced to simple applied electrical circuits, theories and practice to impart skill set to have visualization of electrical engineering applications. It is a course suitable for students pursuing electrical engineering as well as other related engineering disciplines.

Course Outcomes:

At the end of this course, students will able

EE 101.1: To understand and analyse basic electric and magnetic circuits.

EE 101.2: To understand and analysis the AC single phase and three phase circuit

EE101.3: To understand and analysis of the basic principles of various electrical machines

Course Contents:

DC CIRCUITS (7L)

Definition of electric circuit, linear circuit, non-linear circuit, bilateral circuit, unilateral circuit, Dependent source, node, branch, active and passive elements, Kirchhoff's laws, Source equivalence and conversion, Network Theorems-Superposition Theorem, Thevenin's Theorem, Norton Theorem, Maximum Power Transfer Theorem, Star-Delta Conversions.

MAGNETIC CIRCUITS (3L)

Concept of Magnetic circuit, B-H curve, Analogous quantities in magnetic and electric circuits, Faraday's law, iron losses, self and mutual inductance, Energy stored in magnetic field.

AC SINGLE PHASE CIRCUITS (8L)

Sinusoidal quantities, Average and RMS values, peak factor, Form factor, Phase and Phase difference, concept of phasor diagram, V-I Relationship in R,L,C circuit, Combination R,L,C in AC series , parallel and series parallel circuits with phasor diagrams, impedance and admittance, Power factor, Power in AC circuit, Resonance in RLC series and parallel circuit, Q factor, band width of resonant circuit.

THREE PHASE CIRCUITS (3L)

Voltages of three balanced phase system, delta and star connection, relationship between line and phase quantities, phasor diagrams. Power measurement by two watt meters method.

DC MACHINES (6L)

Construction, Basic concepts of winding (Lap and wave). DC generator: Principle of operation, EMF equation, characteristics (open circuit, load) DC motors: Principle of operation, Torque Equation ,Speed Torque Characteristics (shunt and series machine), starting (by 3 point starter), speed control (armature voltage and field control).

SINGLE PHASE TRANSFORMER (5L)

Constructional parts, Types of transformers, Emf equation, No Load no load and on load operation, phasor diagram and equivalent circuit, losses of a transformer, open and short circuit tests, regulation and efficiency calculation.

THREE PHASE INDUCTION MOTOR (6L)

Types, Construction, production of rotating field, principle of operation, Slip and Frequency ,rotor emf and current, Equivalent circuit and phasor diagram, Torque Slip characteristics torque-speed characteristics Starting of induction motor by star delta starter and(DOL starter). Speed Control of Three phase induction motor by variation of supply frequency, supply voltage and number of poles.

GENERAL STRUCTURE OF ELECTRICAL POWER SYSTEM (3L)

Power generation to distribution through overhead lines and underground cables with single line diagram, Earthing of Electrical Equipment, Electrical Wiring Practice

Text books

1. V. Mittle & Arvind Mittal, Basic Electrical Engineering, TMH.
2. Ashfaq Hussain, Basic Electrical Engineering, S. Chand Publication

3. Chakrabarti, Nath & Chanda, Basic Electrical Engineering, TMH
4. C.L. Wadhwa, Basic Electrical Engineering, Pearson Education

Reference books

1. H. Cotton, Willey Press
2. J.B. Gupta, Basic Electrical Engineering, Kataria & Sons .
3. Kothari & Nagrath, Basic Electrical Engineering, TMH

CO-PO mapping:

	PO1	PO2	PO3	PO4	PO5	PO6	PO7	PO8	PO9	PO10	PO11	PO12
EE101.1	3	3	2	1								
EE101.2	2	2	1									
EE101.3	3	2	2									

FOR GROUP B: CSE, IT, FT, ME, CE

Paper Name: Basic Electronics Engineering

Paper code: EC101

Total Contact Hours: 40

Credits: 4

Prerequisites

A basic course in Electronics and Communication Engineering Progresses from the fundamentals of electricity, direct current (DC) devices and circuits , series and parallel circuits to the study of active and passive components, Ohm's Law, Kirchoff's Law i.e. KVL,KCL, Ampere's Law etc.

Course objectives:

Students will be able to Analyze the behaviour of semiconductor diodes in Forward and Reverse bias . To design a half wave and full wave rectifiers , Explore V-I characteristics of Bipolar Junction Transistor n CB, CE & CC configurations. To acquire the basic engineering technique and ability to design and analyze the circuits of Op-Amps. Students will be able to explain feedback concept and different oscillators . They will also be familiar with the analysis of digital logic basics and measuring Electronic devices. Students will have knowledge about characteristics of FET.

Course Outcomes:

EC 101.1	Study PN junction diode, ideal diode, diode models and its circuit analysis, application of diodes and special diodes.
EC 101.2	Learn how operational amplifiers are modeled and analyzed, and to design Op-Amp circuits to perform operations such as integration, differentiation on electronic signals.

EC 101.3	Study the concepts of both positive and negative feedback in electronic circuits.
EC 101.4	Develop the capability to analyze and design simple circuits containing non-linear elements such as transistors using the concepts of load lines, operating points and incremental analysis.
EC 101.5	Learn how the primitives of Boolean algebra are used to describe the processing of binary signals.

Course contents

Module-I: Basics of semiconductor

6L

Conductors, Insulators, and Semiconductors- crystal structure, Fermi Dirac function, Fermi level, E-k and Energy band diagrams, valence band, conduction band, and band gap; intrinsic, and extrinsic (p-type and n-type) semiconductors, position of Fermi level in intrinsic and extrinsic semiconductor, drift and diffusion current – expression only (no derivation) , mass action law , charge neutrality in semiconductor, Einstein relationship in semiconductor , Numerical problems on- Fermi level, conductivity, mass action law, drift and diffusion current .

Module-II: P-N Junction Diode and its applications

8L

p-n junction formation and depletion region , energy band diagram of p-n junction at equilibrium and barrier energy , built in potential at p-n junction ,energy band diagram and current through p-n junction at forward and reverse bias, V-I characteristics and current expression of diode ,temperature dependencies of V-I characteristics of diode , p-n junction breakdown – conditions , avalanche and Zener breakdown , Concept of Junction capacitance, Zener diode and characteristics.

Diode half wave and full wave rectifiers circuits and operation (I_{DC} , I_{rms} , V_{DC} , V_{rms}) , ripple factor without filter, efficiency ,PIV,TUF; Reduction of ac ripples using filter circuit (Qualitative analysis);Design of diode clipper and clamper circuit - explanation with example, application of Zener diode in regulator circuit. Numerical problems.

Module-III : Bipolar junction transistor(BJT)

6L

Formation of PNP/NPN Transistors ,energy band diagram, current conduction mechanism , CE ,CB,CC configurations , transistor static characteristics in CE ,CB and CC mode, junction biasing condition for active,saturation and cut-off modes ,current gain α , β and γ , early effect.

Biasing and bias stability; biasing circuits - fixed bias; voltage divider bias; collector to base bias , D.C. load line and Quiescent point, calculation of stability factors for different biasing circuits.

BJT as an amplifier and as a switch –Graphical analysis; Numerical Problems.

Module-IV: Field effect transistor (FET)

4L

Concept of field effect, channel width modulation Classification of FETs-JFET, MOSFET, operating principle of JFET. drain and transfer characteristics of JFET (n-channel and p-channel), CS,CG,CD configurations, Relation between JFET parameters. FET as an amplifier and as a switch– graphical analysis.E-MOSFET(n-channel and p-channel),D-MOSFET (n-channel and p-channel), Numerical Problems .

Paper Name: Communicative English

Paper Code: HU101

Total Contact Hours: 26

Credits: 2

Pre requisites:

Basic knowledge of high school English.

Course Objectives:

Designed to meet the basic survival needs of communication in the globalized workplace, including knowledge of and competency in the use of macro-skills in reading and writing proficiency, functional grammar and usage.

Course Outcomes:

At the end of this course, students will be

HU101.1: Able to comprehend and communicate in English through exposure to communication skills theory and practice.

HU101.2: Apply the basic grammatical skills of the English language through intensive practice.

HU101.3: Able to develop reading and comprehension skills.

HU101.4: Able to develop writing proficiency skills by writing Official Letters, Technical report, memo, notice, minutes, agenda, resume, curriculum vitae.

HU101.5: Able to apply/illustrate all sets of English language and communication skills in creative and effective ways in the professional sphere of their life

Course Content:

The proposed revised syllabus is as follows:

Module 1: Communication: Interface in a Globalized World [5L]

- a .Definition of Communication& Scope of Communication
- b. Process of Communication—Models and Types
- c. Verbal—Non-Verbal Communication, Channels of Communication
- d. Barriers to Communication & surmounting them

[to be delivered through case studies involving intercultural communication]

Module 2: Vocabulary and Reading [5L]

- a. Word origin—Roots, Prefixes and Suffixes, Word Families, Homonyms and Homophones
- b. Antonyms and Synonyms, One-word substitution
- c. Reading—Purposes and Skills
- d. Reading Sub-Skills—Skimming, Scanning, Intensive Reading
- e. Comprehension Practice (Fiction and Non fictional Prose/Poetry)

Texts:

- (i) Isaac Asimov, *I Robot* (—Robbie OR —Little Lost Robot)
- (ii) George Orwell, —Shooting an Elephant
- (iii) Ruskin Bond, —The Cherry Tree OR —The Night Train at Deoli
- (iv) Robert Frost, —Stopping by the Woods on a Snowy Evening.

f. Precis Writing

(Use of daily newspapers for reading practice is recommended)

Module 3: Functional Grammar and Usage [6L]

- a. Articles, Prepositions, Verbs
- b. Verb-Subject Agreement
- c. Comparison of Adjectives
- d. Tenses and their Use
- e. Transformation of Sentences (Singular-Plural, Active-Passive, Direct-Indirect, Degrees of Comparison)
- f. Error Correction

Module 4: Business writing [10L]

- a. Business Communication in the Present-day scenario
- b. Business Letters (Letters of Inquiry, Sales Letters, Complaint and Adjustment Letters, Job Application Letters)
- c. Drafting of a CV and Résumé
- d. Memo, Notice, Advertisement, Agenda, Minutes of Meetings
- e. E-mails (format, types, jargons, conventions)

References:

1. Raymond Murphy. *English Grammar in Use*. 3rd Edn. CUP, 2001.
2. Seidl & McMordie. *English Idioms & How to Use Them*. Oxford:OUP, 1978.
3. Michael Swan. *Practical English Usage*. Oxford:OUP, 1980.
4. Simeon Potter. *Our Language*. Oxford:OUP, 1950.
5. Pickett, Laster and Staples. *Technical English: Writing, Reading & Speaking*. 8th ed. London: Longman, 2001.
6. IIT Kanpur, English Language & Communication Skills (ENG 112 C) syllabus.

CO-PO Mapping:

CO	PO1	PO2	PO3	PO4	PO5	PO6	PO7	PO8	PO9	PO10	PO11	PO12
HU101.1	-	-	1	-	-	1	-	1	3	3	3	3
HU 101.2	-	-	-	-	-	2	-	-	2	3	3	3
HU 101.3	-	3	2	2	-	3	2	2	3	3	3	3
HU 101.4	-	-	-	2	-	2	-	-	3	3	2	3
HU 101.5	-	2	1	-	-	2	2	1	3	3	2	3

Paper Name: Engineering Mechanics

Paper Code: ME101

Total Contacts Hours: 45

Credit: 4

Pre requisites: Higher Secondary with Physics, Chemistry & Mathematics.

Course Objective:

1. Understand the vector and scalar representation of forces and moments.
2. Describe static equilibrium of particles and rigid bodies in two dimensions and three dimensions including the effect of Friction
3. Analyze the properties of surfaces & solids in relation to moment of inertia.
4. Illustrate the laws of motion, kinematics of motion and their interrelationship.
5. Study the concepts of engineering mechanics on deformable materials under applied loads.

Course Outcome:

Upon successful completion of the course, student should be able to:

ME 101.1. Construct free body diagram and calculate the reactions necessary to ensure static equilibrium.

ME 101.2. Study the effect of friction in static and dynamic conditions.

ME 101.3. Understand the different surface properties, property of masses and material properties.

ME 101.4.Analyze and solve different problems of kinematics and kinetics.

Course Content:

Module1: Importance of Mechanics in engineering; Introduction to Statics; Concept of Particle and Rigid Body; Types of forces: collinear, concurrent, parallel, concentrated, distributed; Vector and scalar quantities; Force is a vector; Transmissibility of a force (sliding vector).
2L

Introduction to Vector Algebra; Parallelogram law; Addition and subtraction of vectors; Lami's theorem; Free vector; Bound vector; Representation of forces in terms of i, j, k ; Cross product and Dot product and their applications.
3L+1T

Two dimensional force system; Resolution of forces; Moment; Varignon's theorem; Couple; Resolution of a coplanar force by its equivalent force-couple system; Resultant of forces
4L+1T

Module2: Concept and Equilibrium of forces in two dimensions; Free body concept and diagram; Equations of equilibrium.
3L+1T

Concept of Friction; Laws of Coulomb friction; Angle of Repose; Coefficient of friction.
3L+1T

Module3: Distributed Force: Centroid and Centre of Gravity; Centroids of a triangle, circular sector, quadrilateral, composite areas consisting of above figures. 4L+1T
Moments of inertia: MI of plane figure with respect to an axis in its plane, MI of plane figure with respect to an axis perpendicular to the plane of the figure; Parallel axis theorem; Mass moment of inertia of symmetrical bodies, e.g. cylinder, sphere, cone.
3L+1T

Principle of virtual work with simple application. 1L+1T

Module4: Concept of simple stresses and strains: Normal stress, Shear stress, Bearing stress, Normal strain, Shearing strain; Hooke's law; Poisson's ratio; Stress-strain diagram of ductile and brittle materials; Elastic limit; Ultimate stress; Yielding; Modulus of elasticity; Factor of safety.
2L+1T

Module5: Introduction to Dynamics: Kinematics and Kinetics; Newton's laws of motion; Law of gravitation & acceleration due to gravity; Rectilinear motion of particles; determination of position, velocity and acceleration under uniform and non-uniformly accelerated rectilinear motion; construction of $x-t$, $v-t$ and $a-t$ graphs. 3L+1T

Plane curvilinear motion of particles: Rectangular components (Projectile motion); Normal and tangential components (circular motion). 2L+1T

Module6: Kinetics of particles: Newton's second law; Equation of motion; D'Alembert's principle and free body diagram; Principle of work and energy ; Principle of conservation of energy; Power and efficiency. 3L+2T

Books Recom mended

1. Engineering Mechanics [Vol-I & II]by Meriam & Kraige, 5th ed. – Wiley India
2. Engineering Mechanics: Statics & Dynamics by I.H.Shames, 4th ed. – PHI
3. Engineering Mechanics by Timoshenko , Young and Rao, Revised 4th ed. – TMH
4. Elements of Strength of Materials by Timoshenko & Young, 5th ed. – E.W.P
5. Fundamentals of Engineering Mechanics by Debabrata Nag & Abhijit Chanda– Chhaya Prakashani
6. Engineering Mechanics by Basudeb Bhattacharyya– Oxford University Press.
7. Engineering Mechanics: Statics & Dynamics by Hibbeler & Gupta, 11th ed. – Pearson

CO-PO Mapping:

CO	PO1	PO2	PO3	PO4	PO5	PO6	PO7	PO8	PO9	PO10	PO11	PO12
ME101.1	3	3	2	2	-	-	-	-	1	-	-	-
ME101.2	3	3	2	2	-	-	-	-	1	-	-	1
ME101.3	3	2	3	2	1	-	-	-	1	-	-	1
ME101.4	3	3	3	3	-	-	-	-	1	-	1	-

Practical

Paper Name: Lang. Lab. and Seminar Presentation

Paper Code: HU191

Total Contact Hours: 26

Credit: 1

Pre requisites: Basic knowledge of LSRW skills.

Course Objectives: To train the students in acquiring interpersonal communication skills by focussing on skill acquisition techniques and error feedback.

Course Outcome:

HU191.1: Able to understand advanced skills of Technical Communication in English through Language Laboratory.

HU191.2: Able to apply listening, speaking, reading and writing skills in societal and professional life.

HU191.3: Able to demonstrate the skills necessary to be a competent Interpersonal communicator.

HU191.4: Able to analyze communication behaviors.

HU191.5: Able to adapt to multifarious socio-economical and professional arenas with the help of effective communication and interpersonal skills.

Course Contents:

Module 1: Introduction to the Language Lab

- a. The Need for a Language Laboratory
- b. Tasks in the Lab
- c. Writing a Laboratory Note Book

Module 2: Active Listening

- a. What is Active Listening?
- b. Listening Sub-Skills—Predicting, Clarifying, Inferencing, Evaluating, Note taking
- c. Contextualized Examples based on Lab Recordings

Module 3: Speaking

- a. Speaking (Choice of words, Speech Syntax, Pronunciation, Intonation)
- b. Language Functions/Speech Acts
- c. Speaking using Picture Prompts and Audio Visual inputs
- c. Conversational Role Plays (including Telephonic Conversation)
- d. Group Discussion: Principles and Practice

Module 4: Lab Project Work

- a. Keeping a Listening Log
- b. Writing a Film Review/Advertisements

References:

1. IT Mumbai, **Preparatory Course in English** syllabus
2. IIT Mumbai, **Introduction to Linguistics** syllabus
3. Sasikumar et al. *A Course in Listening and Speaking*. New Delhi: Foundation Books, 2005.
4. Tony Lynch, *Study Listening*. Cambridge: Cambridge UP, 2004.

CO-PO-Mapping:

CO	PO1	PO2	PO3	PO4	PO5	PO6	PO7	PO8	PO9	PO10	PO11	PO12
HU 191.1	-	3	-	-	-	3	2	1	3	3	3	3
HU 191.2	-	3	-	2	-	3	-	-	3	3	3	3
HU 191.3	-	3	-	-	-	3	-	-	3	3	3	3
HU 191.4	-	3	2	3	-	3	2	-	3	3	3	3

HU 191.5	-	3	2	2	-	2	-	3	3	3	3	3
----------	---	---	---	---	---	---	---	---	---	---	---	---

FOR GROUP A: EE, ECE, EIE/AEIE, BME

Paper Name: Chemistry Lab

Paper Code: CH 191

Total Contact hour: 36

Credit: 2

Pre requisites: 10+2 science with chemistry

Course Objective

Acquiring knowledge on Standard solutions and the various reactions in homogeneous and heterogenous medium. Understanding the basic principles of pH meter and conductivity meter for different applications and analyzing water for its various parameters. Synthesis of Polymeric materials and Nanomaterials.

Course Outcome

CH191.1: Able to operate different types of instruments for estimation of small quantities chemicals used in industries and scientific and technical fields.

CH191.2: Able to work as an individual also as an team member

CH191.3: Able to analyse different parameters of water considering environmental issues

CH191.4: Able to synthesize nano and polymer materials.

CH191.5: Capable to design innovative experiments applying the fundamentals of chemistry

Course contents

List of Experiments:

1. To Determine the alkalinity in given water sample.
2. Redox titration (estimation of iron using permanganometry)
3. To determine calcium and magnesium hardness of a given water sample separately.
4. Preparation of phenol-formaldehyde resin (Bakelite).
5. Heterogeneous equilibrium (determination of partition coefficient of acetic acid between n-butanol and water).
7. Conductometric titration for determination of the strength of a given HCl solution by titration against a standard NaOH solution.
8. pH- metric titration for determination of strength of a given HCl solution against a standard NaOH solution.
9. Determination of dissolved oxygen present in a given water sample.
10. To determine chloride ion in a given water sample by Argentometric method (using chromate indicator solution). **Innovative experiment:** Preparation of silver nano-particles.

Note: From the list of 10 (Ten) experiments a minimum of 7 (seven) experiments shall have to be performed by one student of which Sl. No. 4 (Preparation of Bakelite) has to be mandatory.

CO-PO Mapping:

	PO1	PO2	PO3	PO4	PO5	PO6	PO7	PO8	PO9	P10	P11	P12
CH191.1	3	2	1	1	1	1	-	-	2	-	-	-
CH191.2	-	-	-	-	-	-	-	-	3	-	-	-
CH191.3	-	-	-	-	-	2	3	-	-	-	-	1
CH191.4	-	-	-	-	2	1	-	-	-	-	-	-
CH191.5	2	-	2	-	1	-	-	-	-	-	-	1

FOR GROUP B: CSE, IT, FT, ME, CE

Paper Name: PhysicsI Lab

Paper Code: PH 191

Total Contact Hours: 40

Credit: 4

Pre requisites: Knowledge of Physics upto 12th standard.

Course Outcome of Physics-Ipractical (PH 191)

At the end of the course students' should have the

<p>PH 191.1 :Ability to define, understand and explain</p> <ul style="list-style-type: none"> ✓ Error estimation, Proportional error calculation ✓ superposition principle in Newton's ring, Fresnel's biprism, laser diffraction ✓ Basic circuit analysis in LCR circuits 	PO1
<p>PH 191.2 :Ability to conduct experiments using</p> <ul style="list-style-type: none"> ➤ LASER, Optical fibre ➤ Interference by division of wave front, division of amplitude, diffraction grating, polarization of light ➤ Quantization of electronic energy inside an atom ➤ Torsional pendulum 	PO4

PH 191.3				2								
PH 191.4									3			

FOR GROUP A: EE, ECE, EIE/AEIE, BME

Paper Name: Basic Electrical Engineering LAB

Paper Code: EE191

Total Contact Hours: 36

Credit: 2

Pre requisites:

1. Basic Physics and applied physics.
2. Basic Mathematics.
3. Basic concept of Electric Circuit

Course Objective:

1. Provide knowledge for the analysis of basic electrical circuit.
2. To introduce electrical appliances, machines with their respective characteristics.

Course Outcome:

COs	CO Statement
EE191.1	Identify common electrical components and their ratings.
EE191.2	Make Circuit connection by wires of appropriate ratings.
EE191.3	Understand the usage of common electrical measuring instruments
EE191.4	Understand the basic characteristics of transformers and electrical machines

Course contents

LIST OF EXPERIMENTS

1. Characteristics of Fluorescent ,Tungsten and Carbon filament lamps
2. Verification of Thevenin's and Norton's Theorem
3. Verification of Superposition Theorem
4. Calibration of Ammeter and Wattmeter

5. Study of R-L-C series circuit
6. Open circuit and short circuit test of a single phase Transformer
7. Starting, Reversing of a and speed control of D.C shunt motor
8. Test on single phase Energy Meter
9. Familiarization of PMMC and MI type Meter
10. Familiarization with house wiring practice

CO-PO mapping:

	PO1	PO2	PO3	PO4	PO5	PO6	PO7	PO8	PO9	PO10	PO11	PO12
EE191.1	2	3		1	3				1		2	1
EE191.2	2		2	1	3				1	1		
EE191.3		3				3	2				2	1
EE191.4	3						1			2	2	2

FOR GROUP B: CSE, IT, FT, ME, CE

Paper Name: Basic Electronics Engineering Lab

Paper Code: EC191

Total Contact Hours: 36

Credit: 2

Prerequisites

A basic course in electronics and Communication engineering Progresses from the fundamentals of electricity, active and passive components, basic electronics laws like Ohm's law, Ampere's law

Course objectives:

Students will become familiar with the circuit design using semiconductor diodes in Forward and Reverse bias, They will also be able to design rectifiers like half-wave, full-wave rectifiers etc. using diodes. The ability of circuit design with Bipolar Junction Transistor in CB, CE & CC configurations will be improved. The students will acquire the basic engineering technique and ability to design and analyze the circuits of Op-Amp. Basic concepts and Circuit design with logic gates will be developed in the students. The students will be able design circuit using FET .

Course Outcomes:

EC191.1	Knowledge of Electronic components such as Resistors, Capacitors, Diodes, Transistors measuring equipment like DC power supply, Multimeter, CRO, Signal generator, DC power supply.
EC191.2	Analyze the characteristics of Junction Diode, Zener Diode, BJT & FET and different types of Rectifier Circuits.

EC191.3	Determination of input-offset voltage, input bias current and Slew rate, Common-mode Rejection ratio, Bandwidth and Off-set null of OPAMPs.
EC191.4	Able to know the application of Diode, BJT & OPAMP.
EC191.5	Familiarization and basic knowledge of Integrated Circuits

Course contents:

List of Experiments:

1. Familiarization with passive and active electronic components such as Resistors, Inductors, Capacitors, Diodes, Transistors (BJT) and electronic equipment like DC power supplies, millimeters etc.
2. Familiarization with measuring and testing equipment like CRO, Signal generators etc.
3. Study of I-V characteristics of Junction diodes.
4. Study of I-V characteristics of Zener diodes.
5. Study of Half and Full wave rectifiers with Regulation and Ripple factors.
6. Study of I-V characteristics of BJTs.
7. Study of I-V characteristics of Field Effect Transistors.
8. Determination of input-offset voltage, input bias current and Slew rate of OPAMPs.
9. Determination of Common-mode Rejection ratio, Bandwidth and Off-set null of OPAMPs.
10. Study of OPAMP circuits: Inverting and Non-inverting amplifiers, Adders, Integrators and Differentiators.
11. Study of Logic Gates and realization of Boolean functions using Logic Gates.
12. Study of Characteristic curves for CB, CE and CC mode transistors.
13. Innovative Experiment

CO-PO Mapping

	PO1	PO2	PO3	PO4	PO5	PO6	PO7	PO8	PO9	P10	P11	P12
EC 191.1	3	3	-	-	-	-	-	-	-	-	-	-
EC 191.2	2	3	-	-	-	-	-	-	1	1	-	1
EC 191.3	1	3	3	-	-	-	-	-	-	2	-	-
EC 191.4	1	2	3	-	-	-	-	-	-	1	-	1
EC 191.5	3	1	2	-	-	-	-	-	-	-	-	-

FOR GROUP A: EE, ECE, EIE/AEIE, BME

Paper Name: Engineering Drawing & Graphics

Paper Code: ME 191

Total Contact Hours: 36

Credit: 2

Pre requisites: Higher Secondary with Physics, Chemistry & Mathematics

Course Objective:

1. To learn basics of drafting and use of drafting tools.
2. To know about engineering scales, dimensioning and various geometric curves.
3. To Understand projection of line, surface and solids to create the knowledge base of orthographic and isometric view of structures and machine parts.
4. To acquire the knowledge of Computer Aided drafting using design software.

Course Outcomes: Upon successful completion of this course, the student will be able to:

ME 191.1. Learn basics of drafting and use of drafting tools which develops the fundamental skills of industrial drawings.

ME 191.2. Know about engineering scales, dimensioning and various geometric curves necessary to understand design of machine elements.

ME 191.3. Understand projection of line, surface and solids to create the knowledge base of orthographic and isometric view of structures and machine parts.

ME 191.4. Become familiar with computer aided drafting useful to share the design model to different section of industries as well as for research & development.

Course contents:

List of Experiments:

1. Lines, Lettering, Dimensioning, Scales (Plain scale & diagonal Scale).
2. Geometrical Construction and Curves – Construction of Polygons, Parabola, Hyperbola & ellipse
3. Projection of Points, Lines and Surfaces – orthographic projection- first angle and third angle projection, projection of lines and surfaces- Hexagon
4. Projection of Solids – (Cube, Pyramid, Prism, cylinder and Cone
5. Sectional Views – for simple sold objects
6. Introduction to Computer Aided Drafting – using auto cad & / or similar software- Introduction to Cartesian and polar coordinate systems, absolute and relative coordinates; Basic editing commands: line, point, trace, rectangle, polygon , circle, arc, ellipse, polyline; editing methods; basic object selection methods – window and crossing window, erase, move, copy, offset, fillet, chamfer, trim, extend, mirror; display command; zoom, pan, redraw, regenerate; simple dimensioning and text, simple exercises.

CO Codes	PO1	PO2	PO 3	PO 4	PO 5	PO 6	PO 7	PO 8	PO 9	PO 10	PO 11	PO 12
ME 191.1	2	-	1	2	-	1	-	-	1	-	-	1

ME 191.2	3	-	2	2	-	1	-	-	1	1	-	1
ME 191.3	2	2	2	1	-	1	-	-	1	-	-	1
ME 191.4	1	-	2	2	2	1	-	-	1	1	-	1

FOR GROUP B: CSE, IT, FT, ME, CE

Paper Name: Workshop Practice

Paper Code: ME192

Total Contact Hours: 36

Credit: 2

Pre requisites: Higher Secondary with Physics, Chemistry & Mathematics

Course Objective:

1. To understand the basic knowledge of Workshop Practice and Safety.
2. To identify and use of different hand tools and other instruments like Hand Saw, Jack Plane, Chisels etc and operations like such as Marking, Cutting etc used in manufacturing processes.
3. To get hands on practice in various machining metal joining processes such as Welding, Brazing, Soldering, etc.

Course Outcome:

Upon successful completion of this course, the student will be able to:

ME192.1 Gain basic knowledge of Workshop Practice and Safety useful for our daily living.

ME192.2 Identify Instruments of a pattern shop like Hand Saw, Jack Plain, Chisels etc and performing operations like such as Marking, Cutting etc used in manufacturing processes.

ME192.3 Gain knowledge of the various operations in the Fitting Shop using Hack Saw, various files, Scriber, etc to understand the concept of tolerances applicable in all kind of manufacturing.

ME192. 4 Get hands on practice of in Welding and various machining processes which give a lot of confidence to manufacture physical prototypes in project works.

Course contents

List of Activities:

Sl. No.	Syllabus	Contact Hrs
Module 1	Pattern Making	6

Module 2	Sheet Metal Work	6
Module 3	Fitting	9
Module 4	Machining in Lathe	9
Module 5	Welding	6

MODULE 1 – PATTERN MAKING.

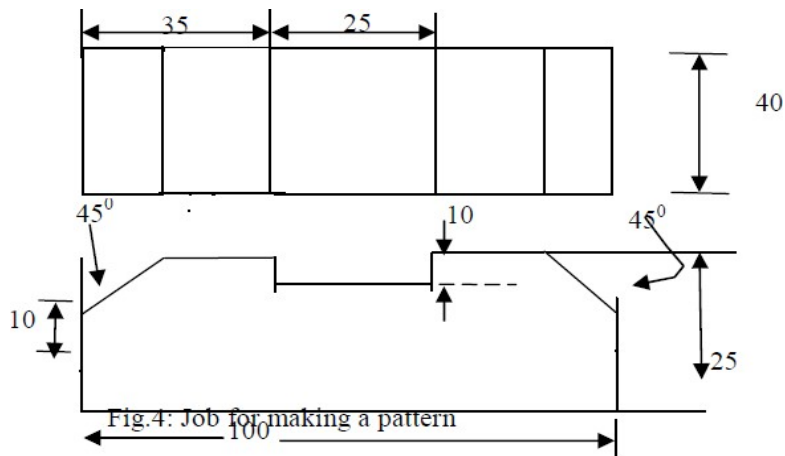

MODULE 3- FITTING SHOP.

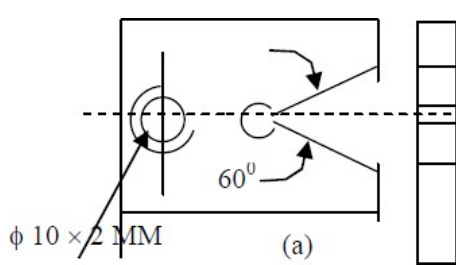

OR

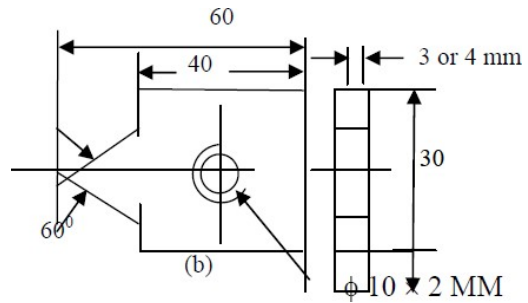

MODULE 4 – MACHINING IN LATHE & SHAPING M/C

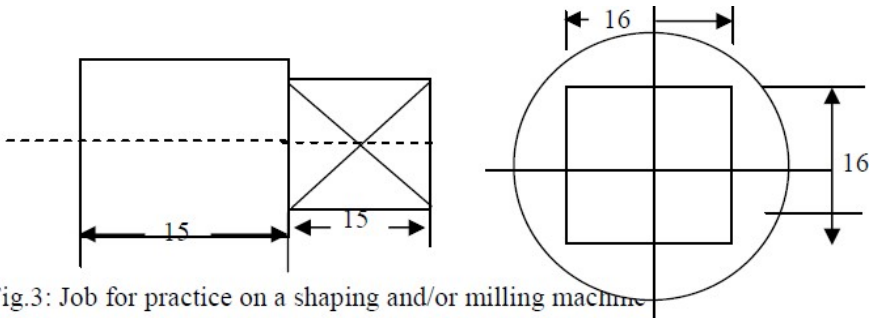
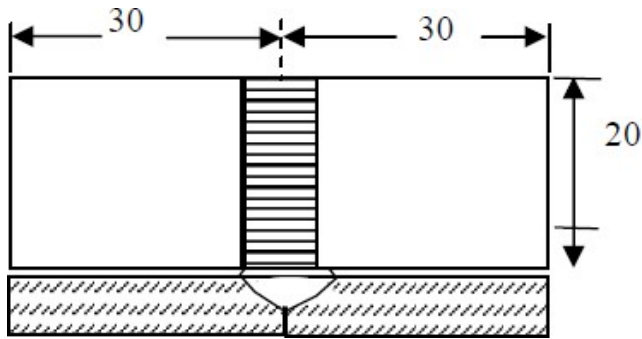

Fig.3: Job for practice on a shaping and/or milling machine

MODULE 5 – WELDING



CO-PO Mapping:

CO Codes	PO1	PO2	PO3	PO4	PO5	PO6	PO7	PO8	PO9	PO10	PO11	PO12
ME 192.1	2	-	-	-	-	2	-	1	-	-	1	-
ME 192.2	2	-	-	-	-	1	-	2	-	-	-	-
ME 192.3	2	-	-	-	-	1	-	1	-	-	-	-
ME 192.4	1	-	-	-	1	3	-	3	-	-	-	1

Sessional

Paper Name: Extra Curricular Activity (NSS/ NCC)

Paper Code: XC 181

Total Contact hours: 20

Credit: 1

Course Objectives: The objectives of the course are as follows:

- To increase student awareness about the weaker and unprivileged sections of society
- To expose students to environmental issues and ecological concerns
- To make students self aware about their participatory role in sustaining society and the environment

Course contents

List of Activities:

- a) Creating awareness in social issues
- b) Participating in mass education programmes
- c) Proposal for local slum area development
- d) Waste disposal
- e) Environmental awareness ``
- f) Production Oriented Programmes
- g) Relief & Rehabilitation work during Natural calamities

Creating awareness in social issues:

1. Women's development – includes health, income-generation, rights awareness.
2. Hospital activities – Eg. writing letters for patients, guiding visitors
3. Old age home – visiting the aging in-mates, arranging for their entertainment.
4. Children's Homes - visiting the young in-mates, arranging for their entertainment
5. Linking with NGOs to work on other social issues. (Eg. Children of sex-workers)
6. Gender issues- Developing an awareness, to link it with Women's Cell of college

Participating in mass education programmes

1. Adult education
2. Children's education

Proposal for local slum area development

One or two slums to be identified and according to the needs, activities to be developed and proposals and reports are to be submitted.

Environmental awareness

- Resource conservation – Awareness to be developed on water, energy, soil.
- Preservation of heritage monuments- Marches, poster campaigns
- Alternative energy consciousness amongst younger school-children.
- Plantation and beautification- Plantation of trees, their preservation and upkeep, developing NSS parks.
- Waste disposal- Proper methods of domestic waste disposal.

Production Oriented Programmes

5. Working with people and explaining and teaching improved agricultural practices

6. Rodent control land pest control practices;
7. Soil-testing, soil health care and soil conservation;
8. Assistance in repair of agriculture machinery;
9. Work for the promotion and strengthening of cooperative societies in villages;
10. Assistance and guidance in poultry farming, animal husbandry, care of animal health etc.;
11. Popularization of small savings and
12. Assistance in procuring bank loans

Relief & Rehabilitation work during Natural calamities

- g) Assisting the authorities in distribution of rations, medicine, clothes etc.;
- h) Assisting the health authorities in inoculation and immunization, supply of medicine etc.;
- i) Working with the local people in reconstruction of their huts, cleaning of wells, building roads etc.;
- j) Assisting and working with local authorities in relief and rescue operation; Collection of clothes and other materials, and sending the same to the affected areas;

Department of Computer Science and **Engineering**

*Curriculum Structure
& Syllabus
(2016-2017)
(Autonomy)*

of

2nd Semester

First Year Second Semester

Group A: ECE, EE, BME, AEIE/EIE

Group B: CSE, IT, FT, ME, CE

Curriculum

THEORY							
Sl No	Paper Code	Theory	Contact Hours /Week				Credit Points
			L	T	P	Total	
1	M 201	Mathematics -II	3	1	0	4	4
2	CH 201/ PH 201	Chemistry (Gr. B) / Physics - I(Gr. A)	3	1	0	4	4
3	EE 201/ EC 201	Basic Electrical Engineering (Gr. B) / Basic Electronics Engineering (Gr. A)	3	1	0	4	4
4	CS 201	Computer Fundamentals & Principle of Computer Programming	3	1	0	4	4
5	ME 201	Engineering Thermodynamics & Fluid Mechanics	3	1	0	4	4
Total of Theory						20	20
PRACTICAL							
6	CS291	Computer Fundamentals & Principle of Computer Programming Lab	0	0	3	3	2
7	CH 291/ PH291	Chemistry Lab (Gr. B) / Physics -I Lab(Gr. A)	0	0	3	3	2
8	EE 291/ EC 291	Basic Electrical Engineering Lab (Gr. B) /Basic Electronics Engineering Lab(Gr. A)	0	0	3	3	2
9	ME 291/ME 292	Engg Drawing & Graphics(Gr B)/ Workshop Practice (Gr- A)	0	0	3	3	2
Total of Practical						12	08
C.SESSIONAL							
10	MC 281	Soft Skill Development	0	0	2	2	0

Syllabus

Theory

Paper Name: Mathematics-II

Paper Code: M 201

Total Contact Hours: 40

Credit: 4

Prerequisite: Any introductory course on calculus.

Course Objective: The purpose of this course is to provide fundamental concepts Ordinary Differential Equations, Graph Theory and Laplace Transform.

Course outcome:

On successful completion of the learning sessions of the course, the learner will be able to:

M 201.1: Recall the distinctive characteristics of Ordinary Differential Equations, Graph Theory and Laplace Transform.

M 201.2: Understand the theoretical workings of various algorithms related to graph theory and the theorems of differential equation and Laplace transforms.

M 201.3: Apply the principles of differential equation, graph theory and Laplace transforms to solve various problems.

Course contents:

Module I

[10L]

Ordinary differential equations (First order): First order and first degree Exact equations, Necessary and sufficient condition of exactness of a first order and first degree ODE (statement only), Rules for finding Integrating factors, Linear equation, Bernoulli's equation, General solution of ODE of first order and higher degree (different forms with special reference to Clairaut's equation), Applications related to Engineering problems.

Module II [10L]

Ordinary differential equations (Higher order): General linear ODE of order two with constant coefficients, C.F. & P.I., D-operator methods for finding P.I., Method of variation of parameters, Cauchy-Euler equations, Solution of simultaneous linear differential equations, Applications related to Engineering problems.

Module III [10L]

Basic Graph Theory: Graphs, Digraphs, Weighted graph, Connected and disconnected graphs, Complement of a graph, Regular graph, Complete graph, Subgraph, Walks, Paths, Circuits, Euler Graph, Cut-sets and cut-vertices, Matrix representation of a graph, Adjacency and incidence matrices of a graph, Graph isomorphism, Bipartite graph. Tree, Binary tree, Spanning tree of a graph, Minimal spanning tree, properties of trees, Algorithms: Dijkstra's Algorithm for shortest path problem, Determination of minimal spanning tree using Kruskal's and Prim's algorithm.

** Extra lecture hours may be taken for this module

M 201.1	3	2	-	-	-	-	-	-	-	-	-	1
M 201.2	3	2	-	-	-	-	-	-	-	-	-	1
M 201.3	3	2	2	-	-	-	-	-	-	-	-	1

FOR GROUP B: ME, CE, IT, CSE, FT

Paper Name: Chemistry

Paper Code: CH 201

Total Contact Hours: 40

Credit: 4

Pre requisites: 10+2 science with chemistry

Course Objective

Understanding of the fundamental theories and applications of thermodynamics, electrochemical principles in modern electrochemical cells and to get an insight into electronic structure of crystals and nanomaterials. Learning about the Synthesis, properties and applications of polymers, fuels and alternative energy sources & their significance in petrochemical industries. Analyzing water quality for its various parameters & its significance in industries

Course Outcome

CH201.1: Able to apply fundamental concepts of thermodynamics in different engineering applications.

CH201.2: Able to analyze & design simple and technologically advanced electrical and energy storage devices.

CH201.3: Able to synthesize nanomaterials, composites, polymers.

CH201.4: Able to apply the basic concept of Organic Chemistry and knowledge of chemical reactions to industries, and technical fields.

CH201.5: Able to apply the knowledge of different fuels and corrosion to different industries

CH201.6: Able to analyse water quality parameter for its various parameters & its significance in industries.

Course contents

Module 1 [8L]

Chemical Thermodynamics –I

1.1 Concept of Thermodynamic system: Definition with example of diathermal wall, adiabatic wall, isolated system, closed system, open system, extensive property, intensive property.

Introduction to first law of thermodynamics: Different statements, mathematical form.

Internal energy: Definition, Example, Characteristics, Physical significance, Mathematical expression for change in internal Energy, Expression for change in internal energy for ideal gas.

2L

1.2 Enthalpy: Definition, Characteristics, Physical significance, Mathematical expression for change in Enthalpy, Expression for change in enthalpy for ideal gas.

Heat Capacity: Definition, Classification of Heat Capacity (C_p and C_V): Definition and General expression of $C_p - C_V$. Expression of $C_p - C_V$ for ideal gas.

Reversible and Irreversible processes: Definition, Work done in Isothermal Reversible and Isothermal Irreversible process for Ideal gas, Adiabatic changes: Work done in adiabatic process, Interrelation between thermodynamic parameters (P , V and T), slope of P - V curve in adiabatic and isothermal process.

Application of first law of thermodynamics to chemical processes: exothermic, endothermic processes, law of Lavoisier and Laplace, Hess's law of constant heat summation. **3L**

1.3 2nd law of thermodynamics: Statement, Mathematical form of 2nd law of thermodynamics (Carnot cycle). Joule Thomson and throttling processes; Joule Thomson coefficient for Ideal gas, Concept of inversion temperature (brief).

Evaluation of entropy: characteristics and expression, physical significance. Work function and free energy: Definition, characteristics, physical significance, mathematical expression of ΔA and ΔG for ideal gas, standard free energy and chemical potential, Condition of spontaneity and equilibrium reaction. **3L**

Module 2 [7L]

2.1 Reaction Dynamics

Reaction laws: rate and order; molecularity; zero and first order kinetics, second order kinetics (same reactant concentration), Pseudounimolecular reaction, Arrhenius equation. **3L**

Mechanism and theories of reaction rates (Content beyond the syllabus)

2.2 Solid state Chemistry

Introduction to stoichiometric defects (Schottky & Frenkel) and non – stoichiometric defects (Metal excess and metal deficiency).

Role of silicon and germanium in the field of semiconductor, n-type, p-type semiconductor, photo voltaic cell, fabrication of integrated circuits. **4L**

Module 3 [8L]

Electrochemistry

3.1 Conductance

Conductance of electrolytic solutions, specific conductance, equivalent conductance, molar conductance and ion conductance, effect of temperature and concentration (Strong and Weak electrolyte). **1L**

3.2 Electrochemical cell

Cell EMF and its Thermodynamic derivation of the EMF of a Galvanic cell (Nernst equation), single electrode potentials, hydrogen half cell, calomel half cell (representation, cell reaction, expression of potential, Discussion, Application). **3L**

3.3 Concept of battery

Battery and Commercial electrochemical cell: Dry cell, acid storage cell, alkaline storage cell, fuel cell (construction, representation, cell reaction, expression of potential, discussion, application). **2L**

3.4 Corrosion and its control

Introduction, cause and effect of corrosion, types of corrosion: dry, wet and other: Electrochemical corrosion, galvanic corrosion, passivation and protective measure. **2L**

Module 4 [12L]

4.1 Structure and reactivity of Organic molecule

Electronegativity, electron affinity, hybridisation, Inductive effect, resonance, hyperconjugation,

CH201.3	-	-	2	-	2	-	-	-	-	-	-	1
CH201.4	2	-	1	-	2	-	-	-	-	-	-	-
CH201.5	2	-	-	-	-	-	2	-	-	-	-	1
CH201.6	-	-	2	-	-	-	1	-	-	-	-	-

FOR GROUP A: EE, ECE, EIE/AEIE, BME

Paper Name: Physics -I

Paper Code: PH 201

Total Contact Hours: 41

Credit: 4

Pre requisites: Knowledge of Physics upto 12th standard.

Course Objective:

The aim of courses in Physics is to provide an adequate exposure and develop insight about the basic physics principles along with the possible applications. The acquaintance of basic principles of physics would help engineers to understand the tools and techniques used in the industry and provide the necessary foundations for inculcating innovative approaches. It can also create awareness of the vital role played by science and engineering in the development of new technologies. It also gives necessary exposure to the practical aspects, which is an essential component for learning sciences.

Course Outcome:

At the end of the course students‘ should have the

<p>PH 201.1 : Ability to state and recall</p> <ul style="list-style-type: none"> ➤ De-Broglie hypothesis, and Heisenberg’s Uncertainty Principle ➤ Amplitude and Velocity Resonance ➤ Malus’s Law, Brewster’s Law ➤ Characteristics of LASER light 	<p>PO1 Or GA1</p>
<p>PH 201.2 : Ability to understand and explain</p> <ul style="list-style-type: none"> ➤ Polarizer and analyzer ➤ basic principles and different types of LASER and Optical Fibre ➤ structure of solids, Miller indices 	<p>PO2 Or GA2</p>

<ul style="list-style-type: none"> ➤ theory of Matter Wave, equation of motion of Matter Wave ➤ wave function and its role in representing wave nature of matter 	
<p>PH 201. 3:Ability to apply the knowledge of</p> <ul style="list-style-type: none"> ➤ mechanical vibration in electrical circuits ➤ superposition principle in Newton’s ring phenomenon, diffraction phenomenon ➤ quantum nature of e.m. waves for production of laser ➤ total internal reflection in transmitting light through optical fibres ➤ x-ray diffraction in crystal structure ➤ probability interpretation in Heisenberg’s uncertainty principle 	<p>PO3</p> <p>Or</p> <p>GA3</p>
<p>PH 201.4:Ability to analyze</p> <ul style="list-style-type: none"> ➤ grating as many slit system ➤ role of Q factor in a resonating circuit, conditions of different types of resonance ➤ minimum requirements for lasing action ➤ importance of light as a carrier of information ➤ the failures of classical physics in microscopic situation and need of quantum physics ➤ Einstein’s A, B coefficient and predict the wavelength domain of Lasing action ➤ Requirement of Miller indices for describing crystallographic planes 	<p>PO2</p> <p>Or</p> <p>GA2</p>
<p>PH 201.5:Ability to evaluate / justify / compare</p> <ul style="list-style-type: none"> ➤ X-ray production process is inverse of the process of Photoelectric Effect. ➤ different crystallographic structures according to their Co-ordination number and packing factors ➤ the outcome of Photo-electric effect, Compton effect and Davission-Germer experiment to justify wave-particle duality of matter 	<p>PO12</p> <p>Or</p> <p>GA12</p>

Course contents

Module 1 (8L):-

Oscillations

1.1 Simple harmonic motion: Concepts with examples, Superposition of SHMs in two mutually perpendicular directions: Lissajous’ figures, Engineering Applications and related Numerical problems

2L

1.2 Damped vibration: Differential equation and its solution, Logarithmic decrement, quality factor, Engineering Applications and related Numerical problems. 3L

1.3 Forced vibration: Differential equation and solution, Amplitude and Velocity resonance, Sharpness of resonance, relevant applications including LCR circuits, Numerical problems 3L

Module 2 (10L):-

Classical Optics:

2.1 Interference of light: Wave nature of light (Huygen's principle), Conditions of sustained interference double slit as an example; qualitative idea of spatial and temporal coherence, conservation of energy and intensity distribution; Newton's ring (qualitative descriptions of working principles and procedures-no deduction required). Engineering applications, Numerical Problems. 3L

Fresnel's biprism (beyond the syllabus). 1L(ext)

2.2 Diffraction of light: Fresnel and Fraunhofer class, Fraunhofer diffraction for plane transmission grating (elementary treatment of intensity distribution for N-slits), single slit and double slits as examples, missing order, Rayleigh criterion, resolving power of grating and microscope (Definition and formula; no deduction required). Engineering Applications, Numerical Problems. 4L

2.3 Polarization: Definition, plane of polarization, plane of vibration, Malus law, fundamental concepts of plane, circular and elliptical polarizations (only qualitative idea) with examples, Brewster's law, Double refraction: ordinary and extraordinary rays, Nicol's prism, Engineering applications, Numerical problems. 3L

Module 3 (9L):-

Quantum Physics:

3.1 Quantum Theory: Inadequacy of classical physics; Planck's quantum hypothesis-Qualitative (without deductions), particle concept of electromagnetic wave (example: photoelectric and Compton effect; qualitative discussions only), wave particle duality; phase velocity and group velocity; de Broglie wave; Davisson and Germer experiment. 4L

3.2 Quantum Mechanics 1: Concept of wave function, Physical significance of wave function, Probability interpretation; wave function normalization condition and its simple numerical applications; uncertainty principle-applications, Schrödinger equation (no mathematical derivation). 4L

Module 4 (6L):

X-ray & Crystallography

4.1 X-rays – Origin of Characteristic and Continuous X-ray, Bragg's law (No derivation), Determination of lattice constant, Applications, Numerical problems. 2L

4.2 Elementary ideas of crystal structure - lattice, basis, unit cell, Fundamental types of lattices – Bravais lattice, Simple cubic, fcc and bcc, hcp lattices, (use of models in the class during teaching is desirable) Miller indices and miller planes, Co-ordination number and Atomic packing factor, Applications, Numerical problems. 4L

Module 5 (8L):

Modern Optics-I:

5.1 Laser: Concepts of various emission and absorption process, working principle of laser, metastable state, Population Inversion, condition necessary for active laser action, optical resonator, ruby laser, He-Ne laser, **semiconductor laser**, Einstein A and B coefficients and equations, industrial and medical applications of laser. 5L

5.2 Fibre optics and Applications: Principle and propagation of light in optical fibres- Numerical aperture and Acceptance angle, V number, Types of optical fibres (material, refractive index, mode), Losses in optical fibre- attenuation, dispersion, bending, Numerical problems. 3L

Recommended Text Books for Physics I (PH101//201):

Oscillations:

1. Classical Mechanics- J. C. Upadhyay (Himalya Publishers)
2. Classical Mechanics-Shrivastav
3. Classical Mechanics-Takwal & Puranik (TMH)
4. Sound-N. K. Bajaj (TMH)
5. Advanced Acoustics-D. P. Roy Chowdhury (Chayan Publisher)
6. Principles of Acoustics-B.Ghosh (Sridhar Publisher)
7. A text book of sound-M. Ghosh (S. Chand publishers)
8. Electricity Magnetism-ChattoPadhyay & Rakshit (New Central Book Agency)
9. A text book of Light- K.G. Mazumder & B.Ghoshs, (Book & Allied Publisher)
10. R.P. Singh (Physics of Oscillations and Waves)
11. A.B. Gupta (College Physics Vol. II)
12. Chattopadhyaya and Rakshit(Vibration,Wavesand Acoustics)

Classical Optics & Modern Optics-I:

13. A text book of Light- K.G. Mazumder & B.Ghoshs (Book & Allied Publisher)
14. A text book of Light-Brijlal & Subhramanium, (S. Chand publishers)
15. Modern Optics-A. B. Gupta (Book & Allied Publisher)
16. Optics-Ajay Ghatak (TMH)
17. Optics-Hecht
18. Optics-R. Kar, Books Applied Publishers
19. Möler(PhysicalOptics)
20. E. Hecht (Optics)
21. E. Hecht (Schaum Series)
22. F.A. Jenkins and H.E White
23. C.R. Dasgupta (Degree Physics Vol 3)

Quantum Physics

24. Introduction to Quantum Mechanics-S. N. Ghoshal (Calcutta Book House)
25. Quantum Mechanics-Bagde Singh (S. Chand Publishers)
26. Perspective of Quantum Mechanics-S. P. Kuilla (New Central Book Agency)
27. Quantum Mechanics-Binayak Datta Roy (S. Chand Publishers)
28. Quantum Mechanics-Bransden (Pearson Education Ltd.)
29. Perspective of Modern Physics-A. Beiser (TMH)
30. Eisberg & Resnick is published by Wiley India
31. A.K. Ghatak and S Lokenathan
32. E.E. Anderson (Modern Physics)
33. Haliday, Resnick & Krane : Physics Volume 2 is Published by Wiley India
34. Binayak Dutta Roy [Elements of Quantum Mechanics]

X-ray & Crystallography

35. Solid state physics-Puri & Babbar (S. Chand publishers)
36. Materials Science & Engineering-Kakani Kakani
37. Solid state physics- S. O. Pillai
38. Introduction to solid state physics-Kittel (TMH)
39. Solid State Physics and Electronics-A. B. Gupta, Nurul Islam (Book & Allied Publisher)
- 40.S.O. Pillai (a. Solid state physics b. Problem in Solid state physics)

General Reference:

1. Refresher courses in physics (Vol. 1, Vol. 2 & Vol. 3)-C. L. Arora (S. Chand Publishers)
2. Basic Engineering Physics-Amal Chakraborty (Chaya Prakashani Pvt. Ltd.)
3. Basic Engineering Physics-I -Sujoy Bhattacharya, Saumen Paul (TMH)
4. Engineering Physics Vol: 1-Sudipto Roy, Tanushri Ghosh, Dibyendu Biswas (S. Chand).
5. Engineering Physics Vol:1-S. P. Kuila (New Central)
4. University Physics-Sears & Zemansky (Addison-Wesley)
- 5.B. Dutta Roy (Basic Physics)
6. R.K. Kar (Engineering Physics)
- 7.Mani and Meheta (Modern Physics)
8. Arthur Baiser (Perspective & Concept of Modern Physics)

CO-PO Mapping:

CO	PO1	PO2	PO3	PO4	PO5	PO6	PO7	PO8	PO9	PO10	PO11	PO12
PH 201.1	1											
PH 201.2		2										
PH 201.3	3											
PH 201.4		1										
PH 201.5												1

FOR GROUP B: CSE, IT, FT, ME, CE

Paper Name: Basic Electrical Engineering

Paper Code: EE 201

Total Contact Hours: 41

Credit: 4

Pre requisite: Basic 12st standard Physics and Mathematics

Course Objective:

Basic electrical engineering is an introductory course in electrical engineering. Students are introduced to simple applied electrical circuits, theories and practice to impart skill set to have visualization of electrical engineering applications. It is a course suitable for students pursuing electrical engineering as well as other related engineering disciplines.

Course Outcomes:

At the end of this course, students will able

EE 201.1: To understand and analyse basic electric and magnetic circuits.

EE 201.2: To understand and analysis the AC single phase and three phase circuit

EE 201.3: To understand and analysis of the basic principles of various electrical machines

Course Contents:**DC CIRCUITS (7L)**

Definition of electric circuit, linear circuit, non-linear circuit, bilateral circuit, unilateral circuit, Dependent source, node, branch, active and passive elements, Kirchhoff's laws, Source equivalence and conversion, Network Theorems-Superposition Theorem, Thevenin's Theorem, Norton Theorem, Maximum Power Transfer Theorem, Star-Delta Conversions.

MAGNETIC CIRCUITS (3L)

Concept of Magnetic circuit, B-H curve, Analogous quantities in magnetic and electric circuits, Faraday's law, iron losses, self and mutual inductance, Energy stored in magnetic field.

AC SINGLE PHASE CIRCUITS (8L)

Sinusoidal quantities, Average and RMS values, peak factor, Form factor, Phase and Phase difference, concept of phasor diagram, V-I Relationship in R,L,C circuit, Combination R,L,C in AC series , parallel and series parallel circuits with phasor diagrams, impedance and admittance, Power factor, Power in AC circuit, Resonance in RLC series and parallel circuit, Q factor, band width of resonant circuit.

THREE PHASE CIRCUITS (3L)

Voltages of three balanced phase system, delta and star connection, relationship between line and phase quantities, phasor diagrams. Power measurement by two watt meters method.

DC MACHINES (6L)

Construction, Basic concepts of winding (Lap and wave). DC generator: Principle of operation, EMF equation, characteristics (open circuit, load) DC motors: Principle of operation, Torque Equation ,Speed Torque Characteristics (shunt and series machine), starting (by 3 point starter), speed control (armature voltage and field control).

SINGLE PHASE TRANSFORMER (5L)

Constructional parts, Types of transformers, Emf equation, No Load no load and on load operation, phasor diagram and equivalent circuit, losses of a transformer, open and short circuit tests, regulation and efficiency calculation.

THREE PHASE INDUCTION MOTOR (6L)

Types, Construction, production of rotating field, principle of operation, Slip and Frequency ,rotor emf and current, Equivalent circuit and phasor diagram, Torque Slip characteristics torque-speed characteristics Starting of induction motor by star delta starter and(DOL starter). Speed Control of Three phase induction motor by variation of supply frequency, supply voltage and number of poles.

GENERAL STRUCTURE OF ELECTRICAL POWER SYSTEM (3L)

Power generation to distribution through overhead lines and underground cables with single line diagram, Earthing of Electrical Equipment, Electrical Wiring Practice

Text books

5. V. Mittle & Arvind Mittal, Basic Electrical Engineering, TMH.
6. Ashfaq Hussain, Basic Electrical Engineering, S. Chand Publication
7. Chakrabarti,Nath & Chanda, Basic Electrical Engineering, TMH
8. C.L. Wadhwa, Basic Electrical Engineering, Pearson Education

Reference books

4. H. Cotton, Willey Press
5. J.B. Gupta, Basic Electrical Engineering, Kataria & Sons .
6. Kothari & Nagrath, Basic Electrical Engineering, TMH

CO-PO mapping:

	PO1	PO2	PO3	PO4	PO5	PO6	PO7	PO8	PO9	PO10	PO11	PO12
EE 201.1	3	3	2	1								
EE 201.2	2	2	1									
EE 201.3	3	2	2									

FOR GROUP A: EE, ECE, EIE/AEIE, BME

Paper Name: Basic Electronics Engineering

Paper code: EC201

Total Contact Hours: 40

Credits: 4

Prerequisites

A basic course in Electronics and Communication Engineering Progresses from the fundamentals of electricity, direct current (DC) devices and circuits , series and parallel circuits to the study of active and passive components, Ohm's Law, Kirchoff's Law i.e. KVL,KCL, Ampere's Law etc.

Course objectives:

Students will be able to Analyze the behaviour of semiconductor diodes in Forward and Reverse bias . To design a half wave and full wave rectifiers , Explore V-I characteristics of Bipolar Junction Transistor n

CB, CE & CC configurations. To acquire the basic engineering technique and ability to design and analyze the circuits of Op-Amps. Students will be able to explain feedback concept and different oscillators . They will also be familiar with the analysis of digital logic basics and measuring Electronic devices. Students will have knowledge about characteristics of FET.

Course Outcomes:

EC 201.1	Study PN junction diode, ideal diode, diode models and its circuit analysis, application of diodes and special diodes.
EC 201.2	Learn how operational amplifiers are modeled and analyzed, and to design Op-Amp circuits to perform operations such as integration, differentiation on electronic signals.
EC 201.3	Study the concepts of both positive and negative feedback in electronic circuits.
EC 201.4	Develop the capability to analyze and design simple circuits containing non-linear elements such as transistors using the concepts of load lines, operating points and incremental analysis.
EC 201.5	Learn how the primitives of Boolean algebra are used to describe the processing of binary signals.

Course contents

Module-I: Basics of semiconductor

6L

Conductors, Insulators, and Semiconductors- crystal structure, Fermi Dirac function, Fermi level, E-k and Energy band diagrams, valence band, conduction band, and band gap; intrinsic, and extrinsic (p-type and n-type) semiconductors, position of Fermi level in intrinsic and extrinsic semiconductor, drift and diffusion current – expression only (no derivation) , mass action law , charge neutrality in semiconductor, Einstein relationship in semiconductor , Numerical problems on- Fermi level, conductivity, mass action law, drift and diffusion current .

Module-II: P-N Junction Diode and its applications

8L

p-n junction formation and depletion region , energy band diagram of p-n junction at equilibrium and barrier energy , built in potential at p-n junction ,energy band diagram and current through p-n junction at forward and reverse bias, V-I characteristics and current expression of diode ,temperature dependencies of V-I characteristics of diode , p-n junction breakdown – conditions , avalanche and Zener breakdown , Concept of Junction capacitance, Zener diode and characteristics.

Diode half wave and full wave rectifiers circuits and operation (I_{DC} , I_{rms} , V_{DC} , V_{rms}) , ripple factor without filter, efficiency ,PIV,TUF; Reduction of ac ripples using filter circuit (Qualitative analysis);Design of diode clipper and clamper circuit - explanation with example, application of Zener diode in regulator circuit. Numerical problems.

Module-III : Bipolar junction transistor(BJT)

6L

Formation of PNP/NPN Transistors ,energy band diagram, current conduction mechanism , CE ,CB,CC configurations , transistor static characteristics in CE ,CB and CC mode, junction biasing condition for active,saturation and cut-off modes ,current gain α , β and γ , early effect.

Biasing and bias stability; biasing circuits - fixed bias; voltage divider bias; collector to base bias , D.C. load line and Quiescent point, calculation of stability factors for different biasing circuits.

BJT as an amplifier and as a switch –Graphical analysis; Numerical Problems.

Module-IV: Field effect transistor (FET)

4L

Concept of field effect, channel width modulation Classification of FETs-JFET, MOSFET, operating principle of JFET. drain and transfer characteristics of JFET (n-channel and p-channel), CS,CG,CD configurations, Relation between JFET parameters. FET as an amplifier and as a switch– graphical analysis.E-MOSFET(n-channel and p-channel),D-MOSFET (n-channel and p-channel), Numerical Problems .

Module-V: Feedback and Operational Amplifier

10L

Concept of feedback with block diagram, positive and negative feedback, gain with feedback. Feedback topologies, effect of feedback on input and output impedance, distortion, concept of oscillation and Barkhausen criterion.

Operational amplifier – electrical equivalent circuit ,ideal characteristics , Non ideal characteristics of op-amp – offset voltages ;bias current ;offset current; Slew rate ; CMRR and bandwidth, Configuration of inverting and non-inverting amplifier using Op-amp, closed loop voltage gain of inverting and non-inverting amplifier , Concept of virtual ground, Applications op-amp – summing amplifier; differential amplifier; voltage follower ; basic differentiator and integrator .

Problems on Characteristics of Op-amp, CMRR, slew rate, amplifier and application of Op-amp to be discussed. Any other relevant problems related to topic may be discussed or assigned.

Module-VI: Cathode Ray Oscilloscope (CRO)

2L

Operating principle of CRO with block diagram, measurement of voltage, frequency and phase.

Module-VII: Digital Electronics

4L

Binary numbers and conversion, Basic Boolean algebra, Logic gates (AND,OR,NOR,NOT,NAND,XOR) and realization of functions.

Text Books:

4. D. Chattopadhyay, P. C. Rakshit, Electronics Fundamentals and Applications, New Age International
5. Millman & Halkias, Integrated Electronics, Tata McGraw Hill.
6. Boyelstad & Nashelsky: Electronic Devices & Circuit Theory, McGraw Hill, 1976.
4. Sedra & Smith, Microelectronics Engineering

Reference Books:

1. John D. Ryder, Electronic Fundamentals and Applications, PHI
2. J.B.Gupta, Basic Electronics, S.K. Kataria.
- 3.Malvino: Electronic Principle.
4. Schilling & Belove: Electronics Circuits.

CO-PO Mapping

	PO 1	PO 2	PO3	PO4	PO5	PO6	PO7	PO8	PO9	P10	P11	P12
EC 201.1	3	-	-	-	-	-	-	-	-	-	-	-
EC 201.2	2	3	-	-	-	-	-	-	-	-	-	1
EC 201.3	1	3	-	-	-	-	-	-	-	-	-	-
EC 201.4	1	2	3	-	-	-	-	-	-	-	-	1
EC 201.5	3	1	-	-	-	-	-	-	-	-	-	-

Computer Fundamentals & Principle of Computer Programming

Code: CS 201

Total No. of Lectures: 40

Credits: 4

Prerequisites:

1. Number system
2. Boolean Algebra

Course Objective(s)

1. To develop the programming skills of students
2. To know the principles of designing structured programs
3. To write basic C programs using
 - i) Selection statements
 - ii) Repetitive statements
 - iii) Functions
 - iv) Pointers
 - v) Arrays
 - vi) Strings

Course Outcome:

CS201.1 Understanding the concept of input and output devices of Computers and how it works and recognize the basic terminology used in computer programming.

CS201.2 Write, Compile and Debug programs in C language and used different data types for writing the programs.

CS201.3 Design programs connecting decision structures, loops and functions.

CS201.4 Explain the difference between call by value and call by address.

CS201.5 Understand the dynamic behavior of memory by the use of pointers.

Use different data structures and create/ manipulate basic data files and developing applications for real world problems.

Course content

Fundamentals of Computer: (10 L)

History of Computer, Generation of Computer, Classification of Computers 1L

Basic structure of Computer System, Primary & Secondary Memory, Processing Unit, Input & Output devices 2L

Binary and Allied number systems representation of signed & unsigned numbers, BCD, ASCII, Binary number Arithmetic – Addition and Subtraction (using 1's complement and 2's complement) 2L

Logic gates – AND, OR, NOT, NAND, NOR, EX-OR, EX-NOR - only truth tables, logic gate symbols and logic equations for gates only 1L

Assembly language, high level language, machine level language, compiler and assembler (basic concepts) 1L

Basic concepts of operating systems like MS DOS, MS WINDOW, UNIX 1L

Problem solving-Algorithm & flow chart 2L

C Fundamentals: (30 L)

Variable and Data Types:

The C character set identifiers and keywords, data type & sizes, variable names, declaration, statements 3L

C Operators & Expressions:

Arithmetic operators, relational operators, logical operators, increment and decrement operators, bitwise operators, assignment operators, conditional operators, special operators - type conversion, C expressions, precedence and associativity.

Input and Output: Standard input and output, formatted output - printf, formatted input scanf, bit fields 5L

Branching and Loop Statements:

Statement and blocks, if - else, switch, goto and labels, Loops - while, for, do while, break and continue 3L

Fundamentals and Program Structures:

auto, external, static and register variables

Functions, function types, function prototypes, functions returning values, functions not returning values, scope rules, recursion, C preprocessor and macro

6L

Arrays, Strings and Pointers:

One dimensional arrays, Two-dimensional arrays, Multidimensional arrays. Passing an array to a function

Character array and string, array of strings, Passing a string to a function, String related functions
Pointers, Pointer and Array, Pointer and String, Pointer and functions, Dynamic memory allocation

6L

Files handling with C:

formatted and unformatted files, Command line arguments, fopen, fclose, fgetc, fputc, fprintf, fscanf function

4L

Structures and Unions:

Basic of structures, arrays of structures, structures and pointers, structures and functions

3L

Text book:

Kerninghan B.W. & Ritchie D.M. - The C Programming Language

Gottfried - Programming with C Schaum

Kanetkar Y. - Let us C

Balaguruswamy - Programming in C

Recommended reference Books:

Pohl and Kelly - A Book on C

Kerninghan, B.W. - The Elements of Programming Style

Schied F.S. Theory and Problems of Computers and Programming

Rajaraman V. Fundamental of Computers

M.M.Oka Computer Fundamentals,EPH

Leon Introduction to Computers,Vikas

Leon- Fundamental of Information Technology,Vikas Ram

B. Computer Fundamentals, New Age International

Ravichandran D. Programming in C, New Age International

Xavier C. Introduction to Computers, New Age International

CO-PO Mapping:

	PO1	PO2	PO3	PO4	PO5	PO6	PO7	PO	PO9	PO10	PO11	PO12
CS201.1	3	3										
CS201.2		2										
CS201.3	3	3										
CS201.4												
CS201.5	3		3	3	3							

Paper Name: Engineering Thermodynamics & Fluid Mechanics

Paper Code: ME 201

Total Contact Hours: 48

Credits: 4

Pre requisites: Higher Secondary with Physics, Chemistry & Mathematics.

Course Objective:

1. To understand the basic principles of thermodynamics, heat and work transfer.
2. To acquire the knowledge of basic concepts of Heat Engine, Entropy from Second law of thermodynamics.
3. To get the knowledge of thermodynamic properties of a pure substance and inter-relationships between key properties of a system or state possessed by the substance.
4. To understand the basic principles of fluid mechanics, and ability to analyze fluid flow problems with the application of the momentum and energy equations.

Course Outcome:

Upon successful completion of this course, the student will be able to:

ME 201.1 Know about thermodynamic equilibrium, heat & work transfer, First law and its application.

ME 201.2 Understand the basic concepts of Heat Engine, Entropy from Second law of thermodynamics.

ME 201.3 Know the thermodynamic characteristics of a pure substance and its application in power cycles (Simple Rankine cycles, Air Standard cycles)

ME 201.4 Knowledge of basic principles of fluid mechanics, and ability to analyze fluid flow problems with the application of the momentum and energy equations

Course content

Module 1:

8L+3T

Basic Concepts of Thermodynamics

Introduction: Microscopic and Macroscopic viewpoints

Definition of Thermodynamic systems: closed, open and isolated systems Concept of Thermodynamics state; state postulate.

Definition of properties: intensive, extensive & specific properties.

Thermodynamic equilibrium

Thermodynamic processes; quasi-static, reversible & irreversible processes; Thermodynamic cycles. Zeroth law of thermodynamics. Concept of empirical temperature.

Heat and Work

Definition & units of thermodynamic work.

Examples of different forms of thermodynamic works; example of electricity flow as work.

Work done during expansion of a compressible simple system

Definition of Heat; unit of Heat

Similarities & Dissimilarities between Heat & Work

Ideal Equation of State, processes; Real Gas

Definition of Ideal Gas; Ideal Gas Equations of State.

Thermodynamic Processes for Ideal Gas; P-V plots; work done, heat transferred for isothermal, isobaric, isochoric, isentropic & polytropic processes.

Equations of State of Real Gases: Van der Waal's equation; Virial equation of state.

Properties of Pure Substances

p-v, T-s & h-s diagrams of pure substance like H₂O

Introduction to steam table with respect to steam generation process; definition of saturation, wet & superheated status.

Definition of dryness fraction of steam, degree of superheat of steam.

Module 2:

4L+3T

1st Law of Thermodynamics

Definition of Stored Energy & Internal Energy 1st Law of Thermodynamics for cyclic processes Non Flow Energy Equation.

Flow Energy & Definition of Enthalpy.

Conditions for Steady State Steady flow: Steady State Steady Flow Energy Equation.

Module 3:

6L+3T

2nd Law of Thermodynamics

Definition of Sink, Source Reservoir of Heat.

Heat Engine, heat Pump & Refrigerator; Thermal efficiency of Heat Engines & co-efficient of performance of Refrigerators

Kelvin – Planck & Clausius statements of 2nd Law of Thermodynamics Absolute or Thermodynamic scale of temperature, Clausius Integral Entropy

Entropy change calculation for ideal gas processes. Carnot Cycle & Carnot efficiency PMM-2; definition & its impossibility

Module 4:

6L+3T

Air standard Cycles for IC Engines

Otto cycle; plot on P-V, T-S planes; Thermal efficiency Diesel cycle; plot on P-V, T-S planes; Thermal efficiency

Rankine cycle of steam

Chart of steam (Mollier's Chart)

Simple Rankine cycle plot on P-V, T-S, h-s planes Rankine cycle efficiency with & without pump work (Problems are to solved for each module)

Module 5:

9L+3T

Properties & Classification of Fluids

Ideal & Real fluids

Newton's law of viscosity; Newtonian and Non-Newtonian fluids

Compressible and Incompressible fluids

Fluid Statics

Pressure at a point

Measurement of Fluid Pressure

Manometers: simple & differential U-tube

Inclined tube

Fluid Kinematics

Streamline

Laminar & turbulent flow

external & internal flow

Continuity equation

Dynamics of ideal fluids

Bernoulli's equation

Total head; Velocity head; Pressure

head Application of Bernoulli's equation

Measurement of Flow rate: Basic principles

Venturimeter, Pilot tube, Orificemeter

(Problems are to be solved for each module)

Engineering Thermodynamics

Text:

- 1 Engineering Thermodynamics - P K Nag, 4th edn, TMH.

References:

- 1 "Fundamentals of Thermodynamics" 6e by Sonntag & Van Wylen published by Wiley India.
- 2 Engineering Thermodynamics – Russel & Adeliyi (Indian edition), OUP
- 3 Engineering Thermodynamics – Onkar Singh, New Age International Publishers Ltd.
- 4 Basic Engineering Thermodynamics – R Joel, 5th Ed., Pearson

Fluid Mechanics

Text:

- 1 Fluid Mechanics and Hydraulic Machines - R Bansal

References:

- 1 Introduction to Fluid Mechanics and Fluid Machines - S.K. Som and G. Biswas. 2nd edn, TMH
- 2 Fluid Mechanics by A.K. Jain.

CO-PO Mapping:

CO	PO1	PO2	PO3	PO4	PO5	PO6	PO7	PO8	PO9	PO10	PO11	PO12
ME201.1	3	3	2	2	-	1	1	1	1	-	1	2
ME201.2	3	3	2	2	-	1	2	-	1	-	1	2

ME201.3	2	2	1	1	-	2	1	-	-	-	-	1
ME201.4	3	3	2	2	-	1	1	-	-	-	1	1

Practical

Paper Name: Computer Fundamentals & Principle of Computer Programming Lab

Paper Code: CS291

Total Contact Hours: 36

Credit: 2

Prerequisites:

3. Basic Computer Knowledge

Course Objective(s):

1. To develop an understanding of the design, implementation, and compilation of a C program
2. To gain the knowledge about pointers, a fundamental for understanding data structure issues
3. To understand the usage of user defined data type for application development

Course Outcome:

CS291.1. Understanding the working of different operating systems like DOS, Windows, Linux.

CS291.2. Write, Compile and Debug programs in C language. **CS291.3.**

Design programs connecting decision structures, loops. **CS291.4.**

Exercise user defined functions to solve real time problems.

CS291.5. Inscribe C programs using Pointers to access arrays, strings, functions, structures and files.

Experiment should include but not limited to the following:

- Some basic commands of DOS, Windows and Linux Operating System, File handling and Directory structures, file permissions, creating and editing simple C program, compilation and execution of C program.
- Writing C Programs on variable, expression, operator and type-casting.

- Writing C Programs using different structures of if-else statement and switch-case statement.
- Writing C Programs demonstrating use of loop (for loop, while loop and do-while loop) concept and use of break and continue statement.
- Writing C Programs demonstrating concept of Single & Multidimensional arrays.
- Writing C Programs demonstrating concept of Function and Recursion.
- Writing C Programs demonstrating concept of Pointers, address of operator, declaring pointers and operations on pointers.
- Writing C Programs demonstrating concept of structures, union and pointer to structure.
- Writing C Programs demonstrating concept of String and command line arguments.
- Writing C Programs demonstrating concept of dynamic memory allocation.
- Writing C Programs demonstrating concept of File Programming.

	PO1	PO2	PO3	PO4	PO5	PO6	PO7	PO	PO9	PO10	PO11	PO12
CS291.1	3	3										
CS291.2		2										
CS291.3	3	3										
CS291.4												
CS291.5	3		3	3	3							

FOR GROUP B: ME, CE, IT, CSE, FT

Paper Name: Chemistry Lab

Paper Code: CH 291

Total Contact Hours: 36

Credit: 2

Pre requisites: 10+2 science with chemistry

Course Objective

Acquiring knowledge on Standard solutions and the various reactions in homogeneous and heterogenous medium. Understanding the basic principles of pH meter and conductivity meter for different applications and analyzing water for its various parameters. Synthesis of Polymeric materials and Nanomaterials.

Course Outcome

CH291.1: Able to operate different types of instruments for estimation of small quantities chemicals used in industries and scientific and technical fields.

CH291.2: Able to work as an individual also as a team member

CH291.3: Able to analyse different parameters of water considering environmental issues

CH291.4: Able to synthesize nano and polymer materials.

CH291.5: Capable to design innovative experiments applying the fundamentals of chemistry

Course contents

List of Experiments:

1. To Determine the alkalinity in given water sample.
2. Redox titration (estimation of iron using permanganometry)
3. To determine calcium and magnesium hardness of a given water sample separately.
4. Preparation of phenol-formaldehyde resin (Bakelite).
5. Heterogeneous equilibrium (determination of partition coefficient of acetic acid between n-butanol and water).
7. Conductometric titration for determination of the strength of a given HCl solution by titration against a standard NaOH solution.
8. pH-metric titration for determination of strength of a given HCl solution against a standard NaOH solution.
9. Determination of dissolved oxygen present in a given water sample.
10. To determine chloride ion in a given water sample by Argentometric method (using chromate indicator solution).

Innovative experiment:

Preparation of silver nano-particles.

Note: From the list of 10 (Ten) experiments a minimum of 7 (seven) experiments shall have to be performed by one student of which Sl. No. 4 (Preparation of Bakelite) has to be mandatory.

CO-PO Mapping:

	PO1	PO2	PO3	PO4	PO5	PO6	PO7	PO8	PO9	P10	P11	P12
CH 291.1	3	2	1	1	1	1	-	-	2	-	-	-
CH 291.2	-	-	-	-	-	-	-	-	3	-	-	-
CH 291.3	-	-	-	-	-	2	3	-	-	-	-	1
CH 291.4	-	-	-	-	2	1	-	-	-	-	-	-
CH 291.5	2	-	2	-	1	-	-	-	-	-	-	1

FOR GROUP A: EE, ECE, EIE/AEIE, BME

Paper Name: Physics I Lab

Paper Code: PH 291

Total Contact Hours: 40

Credit: 4

Pre requisites: Knowledge of Physics upto 12th standard.

Course Outcome of Physics-Ipractical (PH 191)

At the end of the course students' should have the

PH 291.1 :Ability to define, understand and explain ✓ Error estimation, Proportional error calculation ✓ superposition principle in Newton's ring, Fresnel's biprism, laser diffraction ✓ Basic circuit analysis in LCR circuits	PO1
PH 291.2 :Ability to conduct experiments using ➤ LASER, Optical fibre ➤ Interference by division of wave front, division of amplitude, diffraction grating, polarization of light ➤ Quantization of electronic energy inside an atom ➤ Torsional pendulum	PO4
PH 291.3 :Ability to participate as an individual, and as a member or leader in groups in laboratory sessions actively	PO9
PH 291.4 : Ability to analyze experimental data from graphical representations , and to communicate effectively them in Laboratory reports including innovative experiments	PO10

General idea about Measurements and Errors(One Mandatory):

- i) Error estimation using Slide calipers/ Screw-gauge/travelling microscope for one experiment.
- ii) Proportional error calculation using Carrey Foster Bridge.

Any 7 to be performed from the following experiments

Experiments on Oscillations & Elasticity:

1. Study of Torsional oscillation of Torsional pendulum & determination of time period using various load of the oscillator.
2. Experiments on Lissajous figure (using CRO).
3. Experiments on LCR circuit.
4. Determination of elastic moduli of different materials (Young's modulus and Rigidity modulus)

Experiments on Optics:

5. Determination of wavelength of light by Newton's ring method.
6. Determination of wavelength of light by Laser diffraction method.
7. Determination of numerical aperture and the energy losses related to optical fiber experiment
8. Measurement of specific rotation of an optically active solution by polarimeter.

Experiments on Quantum Physics:

11. Determination of Planck's constant using photoelectric cell.
12. Verification of Bohr's atomic orbital theory through Frank-Hertz experiment.

In addition it is **recommended that each student should carry out at least one experiment beyond the syllabus/one experiment as Innovative experiment.

Probable experiments beyond the syllabus:

1. Determination of wavelength of light by Fresnel's bi-prism method (beyond the syllabus).
2. Study of half-wave, quarter-wave plate (beyond the syllabus)
3. Study of dispersive power of material of a prism.
4. Study of viscosity using Poyseullie's capillary flow method/using Stoke's law.
5. Measurement of nodal and antinodal points along transmission wire and measurement of wave length.
6. Any other experiment related to the theory.

CO-PO Mapping:

CO	PO1	PO2	PO3	PO4	PO5	PO6	PO7	PO8	PO9	PO10	PO11	PO12
PH 291.1	2											
PH 291.2	1											
PH 291.3				2								
PH 291.4									3			

FOR GROUP B: ME, CE, IT, CSE, FT

Paper Name: Basic Electrical Engineering LAB

Paper Code: EE 291

Total Contact Hours: 36

Credit: 2

Pre requisites:

4. Basic Physics and applied physics.
5. Basic Mathematics.
6. Basic concept of Electric Circuit

Course Objective:

3. Provide knowledge for the analysis of basic electrical circuit.
4. To introduce electrical appliances, machines with their respective characteristics.

Course Outcome:

COs	CO Statement
EE 291.1	Identify common electrical components and their ratings.
EE 291.2	Make Circuit connection by wires of appropriate ratings.
EE 291.3	Understand the usage of common electrical measuring instruments
EE 291.4	Understand the basic characteristics of transformers and electrical machines

Course contents

LIST OF EXPERIMENTS

11. Characteristics of Fluorescent ,Tungsten and Carbon filament lamps
12. Verification of Thevenin's and Norton's Theorem
13. Verification of Superposition Theorem
14. Calibration of Ammeter and Wattmeter
15. Study of R-L-C series circuit
16. Open circuit and short circuit test of a single phase Transformer
17. Starting, Reversing of a and speed control of D.C shunt motor
18. Test on single phase Energy Meter
19. Familiarization of PMMC and MI type Meter
20. Familiarization with house wiring practice

CO-PO mapping:

	PO1	PO2	PO3	PO4	PO5	PO6	PO7	PO8	PO9	PO10	PO11	PO12
EE 291.1	2	3		1	3				1		2	1
EE 291.2	2		2	1	3				1	1		
EE 291.3		3				3	2				2	1
EE 291.4	3						1			2	2	2

FOR GROUP A: EE, ECE, EIE/AEIE, BME

Paper Name: Basic Electronics Engineering Lab

Paper Code: EC291

Total Contact Hours: 36

Credit: 2

Prerequisites

A basic course in electronics and Communication engineering Progresses from the fundamentals of electricity, active and passive components, basic electronics laws like Ohm's law, Ampere's law

Course objectives:

Students will become familiar with the circuit design using semiconductor diodes in Forward and Reverse bias, They will also be able to design rectifiers like half-wave, full-wave rectifiers etc. using diodes. The ability of circuit design with Bipolar Junction Transistor in CB, CE & CC configurations will be improved. The students will acquire the basic engineering technique and ability to design and analyze the circuits of Op-Amp. Basic concepts and Circuit design with logic gates will be developed in the students. The students will be able design circuit using FET .

Course Outcomes:

EC291.1	Knowledge of Electronic components such as Resistors, Capacitors, Diodes, Transistors measuring equipment like DC power supply, Multimeter, CRO, Signal generator, DC power supply.
EC291.2	Analyze the characteristics of Junction Diode, Zener Diode, BJT & FET and different types of Rectifier Circuits.
EC291.3	Determination of input-offset voltage, input bias current and Slew rate, Common-mode Rejection ratio, Bandwidth and Off-set null of OPAMPs.
EC291.4	Able to know the application of Diode, BJT & OPAMP.
EC291.5	Familiarization and basic knowledge of Integrated Circuits

Course contents:

List of Experiments:

1. Familiarization with passive and active electronic components such as Resistors, Inductors, Capacitors, Diodes, Transistors (BJT) and electronic equipment like DC power supplies, millimeters etc.
2. Familiarization with measuring and testing equipment like CRO, Signal generators etc.
3. Study of I-V characteristics of Junction diodes.
4. Study of I-V characteristics of Zener diodes.
5. Study of Half and Full wave rectifiers with Regulation and Ripple factors.
6. Study of I-V characteristics of BJTs.

7. Study of I-V characteristics of Field Effect Transistors.
8. Determination of input-offset voltage, input bias current and Slew rate of OPAMPs.
9. Determination of Common-mode Rejection ratio, Bandwidth and Off-set null of OPAMPs.
10. Study of OPAMP circuits: Inverting and Non-inverting amplifiers, Adders, Integrators and Differentiators.
11. Study of Logic Gates and realization of Boolean functions using Logic Gates.
12. Study of Characteristic curves for CB, CE and CC mode transistors.
13. Innovative Experiment

CO-PO Mapping

	PO1	PO2	PO3	PO4	PO5	PO6	PO7	PO8	PO9	P10	P11	P12
EC 291.1	3	3	-	-	-	-	-	-	-	-	-	-
EC 291.2	2	3	-	-	-	-	-	-	1	1	-	1
EC 291.3	1	3	3	-	-	-	-	-	-	2	-	-
EC 291.4	1	2	3	-	-	-	-	-	-	1	-	1
EC 291.5	3	1	2	-	-	-	-	-	-	-	-	-

FOR GROUP B: ME, CE, IT, CSE, FT

Paper Name: Engineering Drawing & Graphics

Paper Code: ME 291

Total Contact Hours: 36

Credit: 2

Pre requisites: Higher Secondary with Physics, Chemistry & Mathematics

Course Objective:

To learn basics of drafting and use of drafting tools.

To know about engineering scales, dimensioning and various geometric curves.

To Understand projection of line, surface and solids to create the knowledge base of orthographic and isometric view of structures and machine parts.

To acquire the knowledge of Computer Aided drafting using design software.

Course Outcomes: Upon successful completion of this course, the student will be able to:

ME 291.1. Learn basics of drafting and use of drafting tools which develops the fundamental skills of industrial drawings.

ME 291.2. Know about engineering scales, dimensioning and various geometric curves necessary to understand design of machine elements.

ME 291.3. Understand projection of line, surface and solids to create the knowledge base of orthographic and isometric view of structures and machine parts.

ME 291.4. Become familiar with computer aided drafting useful to share the design model to different section of industries as well as for research & development.

Course contents:

List of Experiments:

1. Lines, Lettering, Dimensioning, Scales (Plain scale & diagonal Scale).
2. Geometrical Construction and Curves – Construction of Polygons, Parabola, Hyperbola & ellipse
3. Projection of Points, Lines and Surfaces – orthographic projection- first angle and third angle projection, projection of lines and surfaces- Hexagon
4. Projection of Solids – (Cube, Pyramid, Prism, cylinder and Cone
5. Sectional Views – for simple sold objects
6. Introduction to Computer Aided Drafting – using auto cad & / or similar software- Introduction to Cartesian and polar coordinate systems, absolute and relative coordinates; Basic editing commands: line, point, trace, rectangle, polygon , circle, arc, ellipse, polyline; editing methods; basic object selection methods – window and crossing window, erase, move, copy, offset, fillet, chamfer, trim, extend, mirror; display command; zoom, pan, redraw, regenerate; simple dimensioning and text, simple exercises.

CO Codes	PO1	PO2	PO 3	PO 4	PO 5	PO 6	PO 7	PO 8	PO 9	PO 10	PO 11	PO 12
ME 291.1	2	-	1	2	-	1	-	-	1	-	-	1
ME 291.2	3	-	2	2	-	1	-	-	1	1	-	1
ME 291.3	2	2	2	1	-	1	-	-	1	-	-	1
ME 291.4	1	-	2	2	2	1	-	-	1	1	-	1

FOR GROUP A: EE, ECE, EIE/AEIE, BME

Paper Name: Workshop Practice

Paper Code: ME 292

Total Contact Hours: 36

Credit: 2

Pre requisites: Higher Secondary with Physics, Chemistry & Mathematics

Course Objective:

1. To understand the basic knowledge of Workshop Practice and Safety.
2. To identify and use of different hand tools and other instruments like Hand Saw, Jack Plane, Chisels etc and operations like such as Marking, Cutting etc used in manufacturing processes.
3. To get hands on practice in various machining metal joining processes such as Welding, Brazing, Soldering, etc.

Course Outcome:

Upon successful completion of this course, the student will be able to:

ME 291.1 Gain basic knowledge of Workshop Practice and Safety useful for our daily living.

ME 291.2 Identify Instruments of a pattern shop like Hand Saw, Jack Plain, Chisels etc and performing operations like such as Marking, Cutting etc used in manufacturing processes.

ME 291.3 Gain knowledge of the various operations in the Fitting Shop using Hack Saw, various files, Scriber, etc to understand the concept of tolerances applicable in all kind of manufacturing.

ME 291.4 Get hands on practice of in Welding and various machining processes which give a lot of confidence to manufacture physical prototypes in project works.

Course contents**List of Activities:**

Sl. No.	Syllabus	Contact Hrs
Module 1	Pattern Making	6
Module 2	Sheet Metal Work	6
Module 3	Fitting	9
Module 4	Machining in Lathe	9
Module 5	Welding	6

MODULE 1 – PATTERN MAKING.

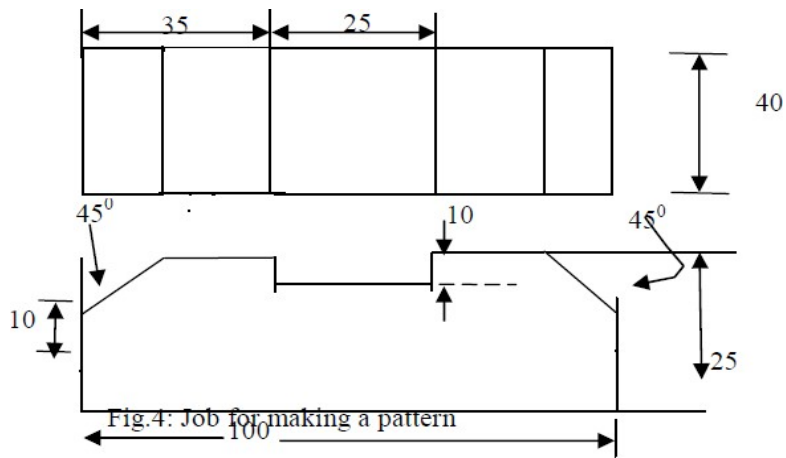

MODULE 3- FITTING SHOP.

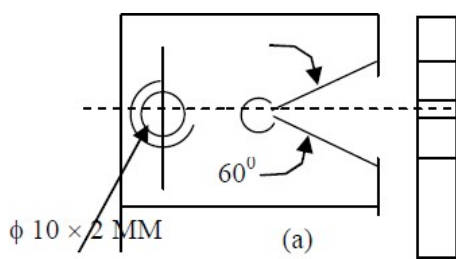

OR

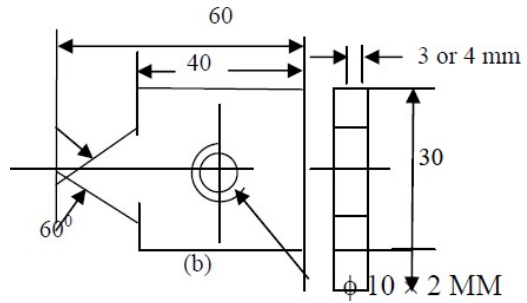

MODULE 4 – MACHINING IN LATHE & SHAPING M/C

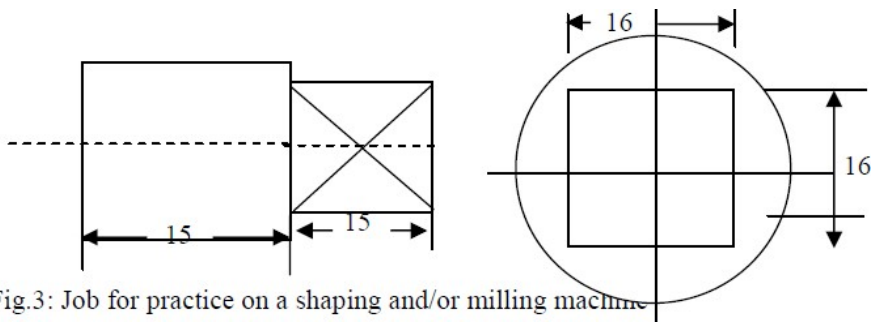
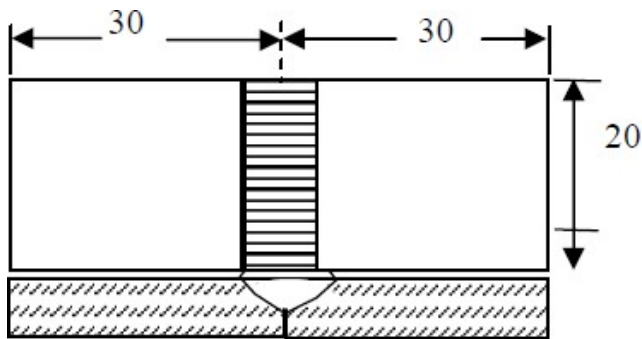

Fig.3: Job for practice on a shaping and/or milling machine

MODULE 5 – WELDING



CO-PO Mapping:

CO Codes	PO1	PO2	PO3	PO4	PO5	PO6	PO7	PO8	PO9	PO10	PO11	PO12
ME 292.1	2	-	-	-	-	2	-	1	-	-	1	-
ME 292.2	2	-	-	-	-	1	-	2	-	-	-	-
ME 292.3	2	-	-	-	-	1	-	1	-	-	-	-
ME 292.4	1	-	-	-	1	3	-	3	-	-	-	1

SESSIONAL

Paper Name: Soft Skills Development

Paper Code: MC-281

Total Contact hours: 26

Course Objectives:

The objectives of this course are as follows:

- To expose the students to different aspects of corporate life and workplace behavior
- To introduce workplace behavioral norms, etiquettes and standards
- To equip students to face interviews, presentations and other professional interactions

MODULE	CONTENT
One	Communication Training
Two	Communication Training (Accent Neutralization)
Three	Business Etiquette
Four	CV / Resume Writing
Five	Corporate Life and Protocols
Six	Group Discussion
Seven	Leadership Skill
Eight	Team Work
Nine	Public Speaking and Interview Basics
Ten	Business Telephone Etiquette
Eleven	Reading skill

Rearrange ?

MODULE ONE – COMMUNICATION TRAINING (2L)

1. Organisational Communication and Structure.
2. Vocabulary related to Corporate Operation.
3. Modes of Communication (Telephone, Conference Call, Team Huddle, Public Relation etc.

4. Communication with Clients, Customers, Suppliers etc.
5. Verbal and Non-Verbal Communication, Proxemics and Para Language.
6. Vocabulary Building (Synonym / Antonym / One word Substitution etc.)

MODULE TWO- COMMUNICATION TRAINING (ACCENT NEUTRALISATION) (2L)

7. Mother Tongue Influence
8. Vowel Sounds and Consonantal Sounds
9. Pronunciation and Neutral Accent.
10. Intonation.
11. Rate of Speech, Pausing, Pitch Variation and Tone.

MODULE THREE – BUSINESS ETIQUETTE (2L)

12. Presenting oneself in the Business Environment.
13. Corporate Dressing and Mannerism.
14. Table Etiquette (Corporate Acculturation, Office parties, Client/Customer invitations etc.)
15. Multi Cultural Etiquette.
16. Cultural Difference.
17. E-mail Etiquette.

MODULE FOUR – JOB APPLICATION AND CV / VIDEO RESUME (2L)

18. Format (Chronological, Skill Oriented, Functional etc.)
19. Style and Appearance.
20. Writing Tips and Video Content Presentation tips.
21. Types of Cover Letter or Job Application Letter.

MODULE FIVE - INTRODUCTION TO CORPORATE LIFE AND PROTOCOLS (2L)

22. Introduction of Companies (Domain Specific)
23. Opportunities and Growth Plan.
24. Performance and Corporate Behaviour.
25. Service Level Agreement and Corporate Jargon.
26. Networking and Adapting to Culture, Technology and Environment.

MODULE SIX – GROUP DISCUSSION (2L)

27. Introduction, Definition and Purpose.
28. Types of Group Discussion.
29. Strategies and Protocols of Group Discussion.
30. Skills and Parameters of Evaluation.
31. Practice Session and Video Viewing Task.

MODULE SEVEN – LEADERSHIP SKILL (2L)

32. Leadership Theories.
33. Traits and Skills of the Leader.
34. Roles, Duties and Responsibilities.
35. Case Study of Leaders.
36. Interpersonal relationship with Team.

MODULE EIGHT – TEAM WORK (2L)

37. Concept of Team Culture.
38. Stages of Team Development (Forming, Storming, Norming, Performing, Adjourning)
39. Team Working Agreement (Participation, Decision Making, Problem Solving.
40. Conflict Management, Flexibility, Negotiation Skill.
41. Team Building (Assess, Plan, Execute and Evaluate)

MODULE NINE – PUBLIC SPEAKING AND INTERVIEW BASICS (2L)

42. Extempore.
43. JAM.
44. Interview Skill
45. Interview over Telephone, Video Conference Interview etc.

MODULE TEN – BUSINESS TELEPHONE ETIQUETTE (2L)

46. Five Phases of a Business Call.
47. Pitch, inflection, Courtesy and Tone.
48. Understanding, Rate of Speech, Enunciation.
49. Hold Procedure.
50. Cold and Hot Transfer protocols.
51. Dealing with Different Types of Customers (Irate, Talkative, Turnaround etc.)

MODULE ELEVEN- READING SKILL

52. Vocabulary from context, speed reading, skimming, inferring, comprehension test etc.

ASSESSMENT		
1.	Viva	10
2.	Personal Skill Enhancement Log	25
3.	Movie Making: Video Resume	25
4.	Term End Project	40

LIST OF REFERENCE:

1. Effective Communication and Soft-Skills: Strategies for Success, Nitin Bhatnagar and Mamta Bhatnagar, Pearson, 2012.
2. Soft Skills: Know yourself and know the World, Dr. K.Alex, S Chand, 2009.
3. Soft Skills at Work: Technology for Career Success, Beverly Amer, Course Technology, 2009.
4. The Pronunciation of English, Daniel Jones, Cambridge University Press, 1998.
5. Global Business Etiquette: A Guide to International Communication and Customs, Jeanette S. Martin and Lillian H. Chaney, Praeger, 2012.
6. The CV Book: Your Definitive Guide to Writing the Perfect CV, James Innes, Pearson.
7. Understanding American Business Jargon: A Dictionary, W. Davis Folsom, Greenwood Press, 2005.
8. Navigating Corporate Life, Stanley Tyo.
9. Group Discussion: A Practical Guide to Participation and Leadership, Kathryn Sue Young, Julia T. Wood, Gerald M. Phillips and Douglas J. Pedersen, Waveland Press Inc., 2007.
10. The Leadership Skills Handbook, Jo Owen, KoganPage, 2006.
11. Teamwork Training, Sharon Boller, ASTD Press, 2005.
12. Public Speaking for Success, Dale Carnegie, Penguin, 2005.
13. Effective Interviewing Skills, Tracey A. Swift and Ivan T. Robertson, BPS Books, 2000.
14. Telephone Etiquette: Making Lasting First Impressions, Theo Gilbert-Jamison, Performance Solutions, 2013.
15. Reading Comprehension Strategies: Theories, Interventions and Technologies, Danielle S. McNamara, Lawrence Earlbaum Associates, 2007.
16. www.mindtools.com.

Department of Computer Science and
Engineering

Curriculum Structure

&

Syllabus

2016-2017

(Autonomy)

of

3rd Semester

3 RD SEMESTER								
SL No	Type	Code	A. THEORY	Contact hours				Cr. Points
				L	T	P	Total	
1	BS	M(CSE)301	Mathematics-III	3	1	0	4	4
2	BS	PH301	Physics-II	3	0	0	3	3
3	ES	EE(CSE)301	Circuit Theory and Network	3	0	0	3	3
4	PC	CS301	Data Structures	3	0	0	3	3
5	PC	CS302	Digital Electronics and Computer Organization	3	0	0	3	3
Total Theory							16	16
<u>B. PRACTICAL</u>								
6	BS	PH391	Physics-II Lab	0	0	3	3	2
7	ES	EE(CSE)391	Circuit Theory and Network Lab	0	0	3	3	2
8	PC	CS391	Data Structures Lab	0	0	3	3	2
9	PC	CS392	Digital Electronics and Computer Organization Lab	0	0	3	3	2
Total Practical							12	8
C. SESSIONAL								
10	HU	HU381	Technical Report writing and Language Practice Lab	0	0	2	2	1
Total							30	25

Syllabus

Theory

Paper Name: Mathematics-III

Paper Code: M (CSE)301

Contact: 3L+1T

Credits: 4

Course: B.Tech

Contact Hours: 4:0:0/Week

Total Lectures: 44L

Prerequisites:

An introductory course on Relation and Function, preliminary understanding of Permutation and Combination and knowledge of basic graph theory.

Course Objective: The purpose of this course is to provide fundamental concepts of Basics of Probability and its Distribution, Discrete Mathematics, Algebraic Structures and Advanced Graph Theory.

Course Outcome(s)

On successful completion of the learning sessions of the course, the learner will be able to:

- Recall the distinctive characteristics of Basic Probability and Probability Distribution, Sampling Theory, Estimation of Parameters, Testing of Hypothesis, Algebraic Structures, Advanced graph Theory.
- Understand the theoretical workings of Basic Probability and Probability Distribution, Sampling Theory, Estimation of Parameters, Testing of Hypothesis, Algebraic Structures, Advanced Graph Theory to evaluate the various measures and forms in related field..
- Demonstrate various real world scenarios using concepts of Basic Probability and Probability Distribution, Sampling Theory, Estimation of Parameters, Testing of Hypothesis, Algebraic Structures, Advanced graph Theory.

Course content

MODULE I:

Basic Probability Theory:

Classical and Axiomatic definition of Probability (elementary properties), conditional probability, Baye's theorem and related problems.

Probability Distributions:

Definition of random variable. Continuous and discrete random variables. Probability density function & probability mass function for single variable only. Distribution function and its properties (without proof). Examples. Definitions of Expectation & Variance, properties & examples. Some important discrete distributions: Binomial, Poisson. Continuous distributions: Normal. Determination of Mean, Variance and standard deviation of the distributions.

Discussions on application of the topic related to CSE

10L

Module II:

Propositional Logic

Introduction to Propositional Calculus, Propositions, Logical Connectives, Conjunction, Disjunction, Negation and their truth table. Conditional Connectives, Implication, Converse, Contrapositive, Inverse, Bi-conditional statements with truth table, Logical Equivalence, Tautology, Normal forms-CNF, DNF; Predicates and Logical Quantifications of propositions and related examples.

Discussions on application of the topic related to CSE

6L

Module III:

Number Theory

Well Ordering Principle, Divisibility theory and properties of divisibility; Fundamental theorem of Arithmetic; Euclidean Algorithm for finding G.C.D and some basic properties of G.C.D with simple examples; Congruence, Residue classes of integer modulo (n) Z_n and its examples.

Partial order Relation and Lattices

PO set, Hasse Diagram, Minimal, Maximal, Greatest and Least elements in a PO set, Lattices and its properties, Principle of Duality, Distributive and Complemented Lattices.

Discussions on application of the topic related to CSE

8L

Module IV:

Principles of Counting Techniques

Permutations, Combinations, Binomial coefficients, Pigeon-hole Principle, Principles of inclusion and exclusions; Recurrence relations: Formulation/Modelling of different counting problems in terms of recurrence relations, Solution of linear recurrence relations with constant coefficients (up to second order) by (i) The iterative method (ii) Characteristic roots method (iii) Generating functions method.

Discussions on application of the topic related to CSE

6L

Module V:

Algebraic Structures

Group, Subgroup, Cyclic group, Permutation group, Symmetric group (S_3), Coset, Normal subgroup, Quotient group, Homomorphism & Isomorphism (**Elementary properties only**).

Definition of Ring, Field, Integral Domain and simple related problems.

Discussions on application of the topic related to CSE

6L

Module VI:

Advanced Graph Theory

Planar and Dual Graphs. Kuratowski's graphs. Homeomorphic graphs. Euler's formula ($n - e + r = 2$) for connected planar graph and its generalisation for graphs with connected components. Detection of planarity, Graph Coloring, Chromatic Numbers and its bounds, Independence and Clique Numbers, Perfect Graphs-Definition and examples, Chromatic polynomial and its determination, Applications of Graph Coloring. Matching: Definitions and Examples of Perfect Matching, Maximal and Maximum Matching, Hall's Marriage Theorem (Statement only) and related problems.

Discussions on application of the topic related to CSE

8L

Total Lectures: 44L

M(CSE) 301.3	3	2	2	-	-	-	-	-	-	-	-	1
-------------------------	---	---	---	---	---	---	---	---	---	---	---	---

Physics-II (Gr-B)

Code: PH 301 [For CSE and IT]

Contacts: 3L/Week

Credit: 3

Total no. of lectures: 33 L

Prerequisite:

Knowledge of Physics up B.Tech 1st year Physics-I course

Course Objective(s)

The Physics-II course will provide

- exposure to the physics of materials that are applied in digital circuitry, storage devices.
- exposure to the physics of quantum logic gate operation and quantum computation
- an insight into the science & technology of next generation.
- foundations of electromagnetic theory and communication systems
- concept of fundamental particles and associated applications in semiconductors

At the end of the course students' should be able to

PH (CSE) 301.1: state and recall Basic postulates of Quantum Mechanics Macro state and micro state for thermodynamic system. Thermodynamic probability and phase space Gauss's law, Faraday's law and Ampere's circuital law. Properties of Nano material.	
---	--

<p>PH (CSE) 301.2: Ability to understand and explain</p> <p>Quantum gates and quantum circuits.</p> <p>Storage devices using magnetic material, semiconductor devices.</p> <p>Quantum confinement.</p> <p>Energy levels and energy states.</p> <p>Distribution functions of Classical and quantum statistics.</p> <p>Displacement current and need of modification of Ampere's circuital law.</p> <p>Concept of quantum well, quantum wire and quantum dots.</p>	
<p>PH (CSE) 301.3: Ability to apply the knowledge of</p> <p>Quantum bit and its representation as a two level system to design quantum logic gates.</p> <p>Quantum gates in designing quantum circuits.</p> <p>Schrödinger equation in problems of junction diode, tunnel diode, 1-D potential box, 3-D potential box.</p> <p>Magnetism and semiconductor physics in data storage.</p> <p>Nano-range and various types of nano materials.</p> <p>Poisson's equation and Laplace's equation to parallel plate, spherical and cylindrical capacitors.</p> <p>Fermi Dirac statistics to metals and semiconductors.</p>	
<p>PH (CSE) 301.4: Ability to Analyze</p> <p>Wide spread applications of electro-magnetic theory</p> <p>Physics of display devices</p> <p>Which type of magnetic materials to be used for data storage purpose</p> <p>Role of optoelectronic devices over usual semiconductor devices</p> <p>Transverse nature of EM wave</p>	
<p>PH (CSE) 301.5: Ability to evaluate or justify or compare</p>	

Non existence of magnetic monopole.	
Under certain conditions quantum statistics collapses to classical statistics	
Magnetic vector and scalar potential	

Module 1: Electricity and Magnetism (8L)

Module 1.01:Electrostatics

Gauss's law in integral form and conversion into differential form, Equation of continuity, Extend to Poisson's & Laplace's equation, Application to parallel plate, spherical and cylindrical capacitors (equivalent 1D problem).
3L

Module 1.02: Magnetostatics:

Lorentz force (concept in Hall effect-), force on a small current element placed in a magnetic field. Biot-Savart law- non existence of magnetic monopole, Ampere's circuital law, Magnetic vector and scalar potential. 3L

Module 1.03: Electro-magnetism &Electromagnetic theory

Faraday's law, Concept of displacement current, Maxwell's field equations with physical significance, wave equation in free space, transverse nature of electromagnetic wave.
2L

Module 2: Quantum Mechanics-II, Quantum Computation and Communication (12L)

2.01: Quantum Mechanics-II

Formulation of quantum mechanics and Basic postulates- superposition principle, orthogonality of wave function, expectation value; operator correspondence, Commutator. Measurements in Quantum Mechanics-Eigen value, Eigen function, Schrödinger's equation as energy eigen value equation. 4L

2.02 : Quantum Computation and Communication

The idea of n- dimensional vector space, use of 'bra-ket' notation, matrix representation of bra & kets; basis, Hilbert space; Pauli matrices. 2L

Idea of qubit and examples of single qubit logic gates- Classical bits, qubit as a two level system; Bloch vector, Pauli gate, Hadamard gate, Phase shift gate, Quantum circuits related to Quantum gates. 3L

Subject Name: Circuit Theory & Networks
Subject Code: EE(CSE)301
Contact Hours/Week: (3L+ 0T)
Credit: 3
Total Contact Hours: 34L

Prerequisite:

1. Basic Electrical Engineering
2. Basic Electronics Engineering

Course Objective(s)

This course is intended for CSE Engineering students to facilitate the student's development into computer engineering investigation. The course has been designed to introduce fundamental principles of electrical circuits as well as the technical skills to analyze such simple circuits. It is a course suitable for students pursuing computer engineering as well as other related engineering disciplines.

Course Outcome(s)

Upon successful completion of this course, the student will have demonstrated:

EE(CSE)301.1 Define various kinds of sources and their symbols, identify and use Kirchhoff's Laws and Networks theorem for simple circuit analyses

EE(CSE)301.2 To introduce the concept of DC & AC transient analysis

EE(CSE)301.3 Deduce expressions and perform calculations relating to the Transient response, Laplace transform, Two port network and Graph theory

EE(CSE)301.4 The Laplace's transform students will able to understand initial & final value theorem and its applications both time & s domain.

EE(CSE)301.5 Ability to solve circuits using node, branch, cutset & tie set and tree

Module 1

Introduction: Continuous & Discrete, Fixed & Time varying, Linear and Nonlinear, Lumped and Distributed, Passive and Active networks and systems. Independent & Dependent sources, Step, Ramp, Impulse, Sinusoidal, Square, Saw tooth signals. 3L

Module 2

Network Equations: Formulation of network equations, Source transformation, Loop variable analysis, Node variable analysis. Network theorem: Superposition, Thevenin's, Norton's & Maximum power transfer theorem and Millman's theorem. Solution of Problems with DC & AC sources. 6L

Module 3

Resonance circuits: Series and parallel resonance- their frequency response, Impedance and Admittance Characteristics, Quality factor, Half Power Points, and bandwidth. Phasor diagrams, Transform diagrams, Practical resonant and series circuits, Solution of Problems. 4L

Module 4

Coupled circuits: Magnetic coupling, polarity of coils, polarity of induced voltage, concept of Self and mutual inductance, Coefficient of coupling, Solution of Problems. 3L

Module 5

Graph of Network: Concept of Tree and Branch, tree link, junctions, (*) Incident matrix, Tie set matrix, Determination of loop current and node voltages. 4L

Module 6

Circuit transients: DC transients in R-L and R-C Circuits with and without initial charge, (*) R-L-C Circuits, AC Transients in sinusoidal R-L, R-C and R-L-C Circuits, Solution of Problems. 2L

Module 7

Laplace transforms: Concept of Complex frequency , transform of $f(t)$ into $F(s)$, transform of step, exponential, over damped surge, critically damped surge, damped and un-damped sine functions , properties of Laplace transform , linearity, real differentiation, real integration, initial value theorem and final value theorem , inverse Laplace transform , application in circuit analysis, Partial fraction expansion, Solution of problems.

8L

Module 8

Two Port Networks Analysis: Relationship of Two port network variables, short circuit admittance parameters, open circuit impedance parameters, transmission parameters, relationship between parameter sets, network functions for ladder network and general network. 4L

Text books :

1. Sudhakar:Circuits& Networks:Analysis & Synthesis 2/e TMH New Delhi
2. Valkenburg M. E. Van, -Network Analysis, Prentice Hall.
3. Roy Choudhury D., -Networks and Systems, New Age International Publishers.
1. Engg Circuit Analysis,: Hayt 6/e Tata Mcgraw-Hill
2. A. Chakrabarti: Circuit Theory Analysis & Synthesis
3. D.Chattopadhyay and P.C.Rakshit: Electrical Circuits

4. A.V. Oppenheimer and A.S.Wilsky: Signals & Systems, PHI
5. R.V.Jalgaonkar.: Network Analysis & Synthesis.EPH.
6. Sivandam- Electric Circuits Analysis.,Vikas

References :

- a. Reza F. M. and Seely S., -Modern Network Analysis, Mc.Graw Hill Book Company
- b. Roy Choudhury D., -Networks and Systems, New Age International Publishers.
- c. Kuo F. F., -Network Analysis & Synthesis, John Wiley & Sons.

CO/PO Mapping												
(3/2/1-indicates strength of correlation) 3-strong, 2-medium, 1-weak												
Cos	Programme Outcomes(Pos)											
	PO1	PO2	PO3	PO4	PO5	PO6	PO7	PO8	PO9	PO10	PO11	PO12
EE(CS E)301.1	3	2	3					2		1		
EE(CS E)301.1	3	2	3				1		3			1
EE(CS E)301.1	3	3	3			1	2		2		2	
EE(CS E)301.1	3	3	3				2	2	1		2	1
EE(CS E)301.1	2	1	2				1					

Name of the Paper: Data Structures

Paper Code: CS301

Contact (Periods/Week):=3L/Week

Credit Point: 3

No. of Lectures: 36

Prerequisite:

1. Familiarity with the fundamentals of C or other programming language
2. A solid background in mathematics, including probability, set theory.

Course Objective(s)

- To learn the basics of abstract data types.
- To learn the principles of linear and nonlinear data structures.
- To build an application using sorting and searching.

Course Outcome(s)

On completion of the course students will be able to

- Differentiate how the choices of data structure & algorithm methods impact the performance of program.
- Solve problems based upon different data structure & also write programs.
- Identify appropriate data structure & algorithmic methods in solving problem.
- Discuss the computational efficiency of the principal algorithms for sorting, searching, and hashing
- Compare and contrast the benefits of dynamic and static data structures implementations.

Module I: Linear Data Structure 10L**Introduction (2L):**

Concepts of data structures: a) Data and data structure b) Abstract Data Type and Data Type.

Algorithms and programs, basic idea of pseudo-code (1L)

Algorithm efficiency and analysis, time and space analysis of algorithms – order notations (1L)

Array (2L):

Different representations – row major, column major (1L)

Sparse matrix - its implementation and usage, Array representation of polynomials (1L)

Linked List (4L):

Singly linked list – operations, Doubly linked list – operations (3L)

Circular linked list – operations, Linked list representation of polynomial and applications (3L)

Module II: Linear Data Structure 6L

Stack and Queue (4L):

Stack and its implementations (using array, using linked list) (1L)

Applications (infix to Postfix, Postfix Evaluation) (1L)

Queue, circular queue de-queue (1L)

Implementation of queue- both linear and circular (using array, using linked list) (1L)

Recursion (2L):

Principles of recursion - use of stack, tail recursion. (1L)

Applications - The Tower of Hanoi, Eight Queens Puzzle (1L)

Module III: Nonlinear Data structures 12L

Trees (8L):

Basic terminologies, forest, tree representation (using array, using linked list) (1L)

Binary trees - binary tree traversal (pre-, in-, post- order) (1L)

Threaded binary tree (1L)

Binary search tree- operations (creation, insertion, deletion, searching) (1L)

Heap(creation, insertion, deletion, searching) (1L)

Height balanced binary tree – AVL tree (insertion with examples only) (1L)

Height balanced binary tree – AVL tree (deletion with examples only) (1L)

m –Way Search Tree, B⁺ Tree – operations (insertion, deletion with examples only) (1L)

Graphs (4L):

Graph definitions and concepts (directed/undirected graph, weighted/un-weighted edges, sub-graph, degree, cut-vertex/articulation point, pendant node, clique, complete graph, connected components – strongly connected component, weakly connected component, path, shortest path, isomorphism) (1L)

Graph traversal and connectivity – Depth-first search (DFS), Breadth-first search (BFS) - concepts of edges used in DFS and BFS (tree-edge, back-edge, cross-edge, and forward-edge) (2L)

Minimal spanning tree – Prim’s algorithm, Kruskal’s algorithm (basic idea of greedy methods) (1L)

Module IV: Searching, Sorting 8L

Sorting Algorithms (4L):

Bubble sort, Insertion sort, Selection sort– with complexity (1L)

Quick sort, Merge sort – with complexity (2L)

Radix sort – with complexity (1L)

Searching (2L):

Sequential search – with complexity (1L)

Binary search, Interpolation Search– with complexity(1L)

Hashing (2L):

Hashing functions (1L)

Collision resolution techniques (1L)

Text books:

1. –Fundamentals of Data Structures of C++ by Ellis Horowitz, SartajSahni, Susan Anderson-freed

Recommended books:

1. “The Art of Computer Programming” by Donald Knuth

2. “Data Structures, Algorithms, and Software Principles in C” by Thomas A. Standish
3. “Data Structures” by S. Lipschutz
4. “Data Structures and Program Design In C”, 2/E by Robert L. Kruse, Bruce P. Leung
5. “Data Structures in C” by Aaron M. Tenenbaum

CO	PO1	PO2	PO3	PO4	PO5	PO6	PO7	PO8	PO9	PO10	PO11	PO12
CS301.1	3	3	2	2	3	2	2	3	3	3	2	3
CS301.2	3	2	2	2	2	2	3	2	2	3	3	2
CS301.3	3	3	3	2	3	3	3	2	2	3	3	2
CS301.4	3	3	3	3	3	3	3	3	3	3	3	3
CS301.5	3	3	3	3	3	3	3	3	3	3	3	3
CS301	3	3	3	2	3	3	3	3	3	3	3	3

Paper Name: Digital Electronics and Computer Organization

Paper Code: CS302

Contact Hours/Week: 3

Credit:3

Total Contact Hours: 36L

Prerequisite:

1. Computer Fundamentals and principal of computer programming
2. Basic Electronics Engineering

Course Objective(s)

- To acquire the basic knowledge of digital logic levels and application of knowledge to understand digital electronics circuits.
- To prepare students to perform the analysis and design of various digital electronic circuits.
- To know how Computer Systems work & its basic principles,
- To know how I/O devices are being accessed and its principles etc

Course Outcome(s)

CS302.1 Realize basic gate operations and laws Boolean algebra.

CS302.2 Understand basic structure of digital computer, stored program concept and different arithmetic and control unit operations.

CS302.3 Understand basic structure of different combinational circuits- multiplexer, decoder, encoder etc.

CS302.4 Perform different operations with sequential circuits.

CS302.5 Understand memory and I/O operations.

Module – 1: [3L]

Introduction, concepts and laws of Boolean algebra [1L], Boolean functions and Representation in SOP and POS forms [1L], Minterm and maxterm , Minimization of logic expressions by Karnaugh Map [1L]

Module – 2: [7L]

Combinational circuits:

Adder and Subtractor (half-full adder & subtractor) [2L], Carry look ahead adder and Parity Generator [1L], Encoder, Decoder, Multiplexer [2L], De-Multiplexer , Comparator [1L], Basic Concepts of A/D and D/A converters [1L]

Module – 3: [8L]

Sequential Circuits:

Basic Flip-flop- SR, JK, D, T and JK Master-slave Flip Flops [3L], Registers (SISO, SIPO, PIPO, PISO) [2L]
Ring counter, Johnson counter [1L], Basic concept of Synchronous and Asynchronous counters [1L], Design of Modulo-N Counter [1L],

Module – 4:[9L]

Stored program concept-Von Neumann and Harvard architecture [1L]
Introduction to CPU and concepts of ALU [2L], Instruction format and Instruction Cycle [1L], Addressing Modes [1L]
Fixed-point multiplication - Booth's algorithm. [1L], Fixed-point division - Restoring and non-restoring algorithms. [1L]
Floating-point number representation- IEEE 754 format and Floating-point arithmetic operation [2L]

Module – 5: [4L]

Introduction to memory-RAM and ROM [2L], Register transfer, memory transfer, Tri-state bus buffer [1L], Microprogrammed and hardwired control unit [1L]

Module – 6:[5L]

Introduction to I/O operations [1L], Synchronous and asynchronous transfer [1L], Modes of transfer [1L], Bus Arbitration [1L], Input-output processor [1L]

Text Book:

David A. Patterson and John L. Hennessy- Computer Organization and Design: The Hardware/Software Interface

Morris Mano- Digital Logic Design- PHI

Reference Book:

Hayes J. P., -Computer Architecture & Organisation, McGraw Hill,

William Stallings, Computer Organization and Architecture: Designing for Performance

CO/PO Mapping												
(S/M/W indicates strength of correlation) S-Strong, M-Medium, W-Weak												
COs	Programme Outcomes(POs)											
	PO1	PO2	PO3	PO4	PO5	PO6	PO7	PO8	PO9	PO10	PO11	PO12
	K=3	K=4	K=5	K=6	K=6							
CS302.1	3	2										
CS302.2	3	3		2			2					
CS302.3	3	3										
CS302.4			3	3	3				2			
CS302.5	3	2				2			2		2	

Practical

Subject Name: Circuit Theory & Network Lab

Subject Code: EE(CSE)391

Contact Hours/Week: 3P

Credits: 2

Prerequisite: Concepts of Basic Electrical Engineering, Software Tools (Pspice/ Multisim/Matlab)

Course Objective:

This course enables the students to

1. The ability to conduct testing and experimental procedures on circuit analysis by using software and hardware tools
2. To prepare the students to have a basic constructional knowledge of Step, Ramp, Impulse, Sinusoidal, signals
3. Transient analysis of different electrical circuits with and without initial conditions using Laplace Transform.

Course outcomes:

Having successfully completed the course, student will be able to:

EE(CSE)391.1: Evaluate lecture material with circuit simulation software and laboratory bench experiments

	1											
EE(C SE)3 91.1	2	2		3								
EE(C SE)3 91.2		2		3								
EE(C SE)3 91.3	2			3					1			
EE(C SE)3 91.4		2		3								

Name of the Paper: Data Structures Lab

Paper Code: CS391

Contact (Periods/Week): L-T-P=0-0-3

Credit Point: 2

No. of Lab: 11

Perquisite

1. Computer Fundamentals and principal of computer programming Lab

Objectives:

- To write and execute programs in C to solve problems using data structures such as arrays, linked lists, stacks, queues, trees, graphs, hash tables and search trees.
- To write and execute write programs in C to implement various sorting and searching methods.

Outcomes:

CS391.1 Choose appropriate data structure as applied to specified problem definition.

CS391.2 Handle operations like searching, insertion, deletion, traversing mechanism on various data structures.

CS391.3 Have practical knowledge on the applications of data structures.

CS391.4 Able to store, manipulate and arrange data in an efficient manner.

CS391.5 Able to implement queue and stack using arrays and linked list. Implementation of queue, binary tree and binary search tree.

Module 1

1. Write a C program that uses functions to perform the following:
 - a. Create a singly linked list of integers.
 - b. Delete a given integer from the above linked list.
 - c. Display the contents of the above list after deletion.
2. Write a C program that uses functions to perform the following:
 - a. Create a doubly linked list of integers.
 - b. Delete a given integer from the above doubly linked list.
 - c. Display the contents of the above list after deletion.
3. Write a C program to implement Polynomial addition and Polynomial multiplication using Linked List.
4. Write a C program that uses stack operations to convert a given infix expression into its postfix Equivalent, Implement the stack using an array.
5. Write C programs to implement a queue ADT using i) array and ii) doubly linked list respectively.

Module 2

6. Write a C program that uses functions to perform the following:
 - a. Create a binary search tree of characters.
 - b. Traverse the above Binary search tree recursively in Postorder.
7. Write a C program that uses functions to perform the following:
 - a. Create a binary search tree of integers.
 - b. Traverse the above Binary search tree non recursively in inorder.

Module 3

8. Write C programs for implementing the following sorting methods to arrange a list of integers in ascending order:
 - a. Insertion sort
 - b. Merge sort

9. Write C programs for implementing the following sorting methods to arrange a list of integers in ascending order:

- a. Quick sort
- b. Selection sort

10. Write C programs for implementing the following searching methods:

- a. Linear Search
- b. Binary Search

Write a C program to implement all the functions of a dictionary (ADT) using hashing.

Module 4

11. Write C programs for implementing the following graph traversal algorithms:

- a. Depth first search
- b. Breadth first search

Text Books:

1. C and Data Structures, Third Edition, P.Padmanabham, BS Publications.
2. C and Data Structures, Prof. P.S.Deshpande and Prof. O.G. Kakde, Dreamtech Press.
3. Data structures using C, A.K.Sharma, 2nd edition, Pearson.
4. Data Structures using C, R.Thareja, Oxford University Press.
5. C and Data Structures, N.B.Venkateswarlu and E.V.Prasad,S.Chand.
6. C Programming and Data Structures, P.Radha Krishna, Hi-Tech Publishers.

CO	PO1	PO2	PO3	PO4	PO5	PO6	PO7	PO8	PO9	PO10	PO11	PO12
CS391.1	3	3	2	2	2	2	1	1		1		
CS391.2	3	2	2		2	2	1			1		2
CS391.3	2	1	1					1				
CS391.4	3	2		2		1	1		1		1	
CS391.5	1		2	1	2			1	1		1	2
CS391	3	2	2	2	2	2	1	1	1	1	1	2

Paper Name: Digital Electronics and Computer Organization Lab

Paper Code: CS392

Contact Hours/Week: 3

Credit: 2

Prerequisite:

Basic concepts of Logicgates, Truth Tables, function realization –minimization of Logic expressions by K-map, Concept of basic components of a digital computer, Binary Arithmetic

Course objective:

This subject will act as prerequisite for computer architecture. The aims of this lab are to make students familiar with the principles of combinational and sequential digital logic design and optimization at a gate level and designing various circuits with ICs.

Course outcome:

After the completion of this lab, students will be able to

CS392.1 Realize basic gate operations

CS392.2 Understand basic structure of digital computer.

CS392.3 Understand basic structure of different digital components- multiplexer, decoder, encoder etc.

CS392.4 Perform different operations with flip-flop.

CS392.5 understand arithmetic and control unit operations

1. A) Realization of basic gates and universal gates.
B) Realization of basic gates using universal gates.
2. Design a Half adder and Full Adder circuit using basic gates and verify its output.
3. Design a Half subtractor and Full Subtractor circuit using basic gates and verify its output
4. Design an Adder/Subtractor composite unit.
5. Design of a ‘_Carry-Look-Ahead’ Adder circuit.
6. Realization of a)Encoder, b)Decoder c) Multiplexer , d) De-MUX , e)Comparator and their Truth Table verification.
7. Realization of RS / JK / D flipflops using logic gates.
8. Design of Shift Register using J-K / D Flip Flop.
9. Realization of Synchronous Up/Down counters.
10. Design of MOD- N Counter
11. Design a composite ALU for multi-bit arithmetic operation.
12. Design of RAM.

CO/PO Mapping												
(S/M/W indicates strength of correlation) S-Strong, M-Medium, W-Weak												
	Programme Outcomes(POs)											
	PO1	PO2	PO3	PO4	PO5	PO6	PO7	PO8	PO9	PO10	PO11	PO12
	K=3	K=4	K=5	K=6	K=6							
CS392.1	3	2										
CS392.2	3	3		2			2					
CS392.3	3	3										
CS392.4			3	3	3				2			
CS392.5	3	2				2			2		2	

Course Title: Technical Report Writing & Language Practice

Course Code: HU381

Contact Hours/Week (P): 2

Credits: 1

Program: 2nd Year B. Tech Sem-3

Pre-requisites: A basic knowledge of listening and speaking skills and the ability to infer meaning from audio-video/online lessons.

Course Objectives: To maximize exposure and train students in the professional use of English in the globalized workplace.

Course outcome:

By the end of the course the student should be able to

HU381.1 Understand and make use of a wide taxonomy of listening skills & sub-skills for comprehending & interpreting data in English

HU381.2: Speak in English, using appropriate vocabulary and pronunciation in contextualized situations

HU381.3: Understand and put into effective practice the pragmatics of Group Discussion

HU381.4: Understand and write a detailed technical report as per organizational needs

HU381.5: Understand and interact in professional presentations and interviews

Syllabus:

Module 1: The Need for a Language Laboratory [2L+2P]

- (a) Introduction to the Language Lab
- (b) Skill-building exercises in the lab

Module 2: Power Listening [2L+3P]

- (a) Taxonomy of Listening Skills & Sub-skills [Aural Skimming, Scanning, Listening for Details, Note taking, Evaluative Listening, Empathetic Listening, Paralinguistic and Kinesic Inferencing]
- (b) Audio-based Lessons
- (c) Repairing Listening ‘Gaps’ through Learner Feedback

Module 3: Speaking Skills [2L+6P]

- (a) The Need for Speaking: Content and Situation-based speaking
- (b) Speaking Activities: [Just a Minute, Paired Role Play, Situational Speaking Exercises]
- (c) The Pragmatics of Speaking—Pronunciation practice and learner feedback.

Module 4: Group Discussion [2L+6P]

- (a) Teaching GD Strategies
- (b) In-house video viewing sessions
- (c) Group Activities [Topic Brainstorming, Situational Analysis, Frame Story]
- (d) Extended Practice and feedback

Module 5: Writing a Technical Report [2L+6P]

- (a) Organizational Needs for Reports and types
- (b) Report Formats
- (c) Report Writing Practice Sessions and Workshops

Module 6: SWOT Analysis [2L+3P]

- (a) SWOT Parameters
- (b) Organizational SWOT
- (c) Case Study

Module 7: Presentation [2L+6P]

- (a) Teaching Presentation as a Skill
- (b) Speaking Strategies and Skills
- (c) Media and Means of Presentation
- (d) Extended Practice and Feedback

Module 8: Personal Interview [2L+3P]

- (a) Preparing for the Interview: Interview Basics, Dressing and Grooming, Q & A
- (b) Mock Interview sessions and feedback

Mapping:

	PO1	PO2	PO3	PO4	PO5	PO6	PO7	PO8	PO9	P10	P11	P12
HU381.1	3	-	-	3	-	3	-	-	3	3	-	-
HU381.2	2	3	2	3	-	3	-	-	2	3	-	1
HU381.3	1	3	-	3	-	2	-	-	2	3	-	1
HU381.4	1	2	3	3	-	2	-	-	2	3	-	-
HU381.5	3	3	2	3	-	2	-	-	2	3	-	1

Department of Computer Science and
Engineering

Curriculum Structure

&

Syllabus

2016-2017

(Autonomy)

of

4th Semester

4 th Semester								
SL No	Type	Code	A. THEORY	Contact hours				Cr. Points
				L	T	P	Total	
1	BS	M(CSE)401	Numerical Methods and Statistics	3	0	0	3	3
2	HS	HU401	Environmental science	2	0	0	2	2
3	PC	CS401	Computer Architecture	3	0	0	3	3
4	PC	CS402	Design and Analysis of Algorithms	3	0	0	3	3
5	PC	CS 403	Formal Language And Automata Theory	3	0	0	3	3
Total Theory							14	14
			<u>B. PRACTICAL</u>					
6	BS	M(CSE)491	Numerical Methods and Statistics Lab	0	0	3	3	2
7	PC	CS491	Computer Architecture Lab	0	0	3	3	2
8	PC	CS492	Algorithms Lab	0	0	3	3	2
9	PC	CS493	Programming with C++ Lab	1	0	2	3	2
Total Practical							12	8
			<u>C. MANDATORY COURSES</u>					
10	MC	MC 481	Technical Communication & Soft Skills	0	0	3	3	2 Unit
Total							29	22

Syllabus

Theory

Subject Name: Numerical Methods and Statistics

Subject Code: M (CSE) 401

Year: Second Year

Contact Hours: 3L/Week

Credit: 3

Prerequisite: Concept of Calculus and Algebra.

Course Objective

The purpose of this course is to provide basic understanding of the derivation and the use of the numerical methods along with the knowledge of finite precision arithmetic and fundamental concepts of Statistics.

Course Outcome(s)

On successful completion of the learning sessions of the course, the learner will be able to:

M(CSE)401.1 Recall the distinctive characteristics of various numerical techniques and the associated error measures and Statistics.

M(CSE)401.2 Understand the theoretical workings of various numerical techniques and Statistics to solve the engineering problems and demonstrate error.

M(CSE)401.3 Apply the principles of various numerical techniques and statistics to solve various problems.

Module I: Numerical Method I

Approximation in numerical computation: Truncation and rounding errors, Propagation of errors, Fixed and floating-point arithmetic. (2L)

Interpolation: Calculus of Finite Differences, Newton forward/backward interpolation, Lagrange's interpolation, Divided difference and Newton's divided difference Interpolation. (5L)

Numerical integration: Newton Cotes formula, Trapezoidal rule, Simpson's 1/3 rule, Expression for corresponding error terms. (3L)

Numerical solution of a system of linear equations: Gauss elimination method, LU Factorization method, Gauss-Seidel iterative method. (3L)

Solution of polynomial and transcendental equations: Bisection method, Regula-Falsi, Newton-Raphson method. (3L)

Module II: Numerical Method II

Numerical solution of ordinary differential equation: Taylor series method, Euler's method, Euler's modified method, Milne's Predictor-Corrector Method, Fourth order Runge-Kutta method. (5L)

Numerical solution of partial differential equation: Finite Difference method, Crank-Nicolson method. (2L)

Subject: Environmental Science
Subject Code: HU 401
Contact Hours: 2L/Week
Credits: 2L

Pre requisites: 10+2 science with chemistry

Course Objective(s)

- Be able to understand the natural environment and its relationships with human activities.
- Be able to apply the fundamental knowledge of science and engineering to assess environmental and health risk.
- Be able to understand environmental laws and regulations to develop guidelines and procedures for health and safety issues.
- Be able to solve scientific problem-solving related to air, water, noise & land pollution.

Course Outcome(s)

- To understand the natural environment and its relationships with human activities.
- To apply the fundamental knowledge of science and engineering to assess environmental and health risk.
- To develop guidelines and procedures for health and safety issues obeying the environmental laws and regulations.
- Acquire skills for scientific problem-solving related to air, water, noise & land pollution.

1. General

6L

1.1 Natural Resources: Forest Resource, water resource, mineral resource, energy resources (renewable, non-renewable, potentially renewable)

1.2 Population Growth: Exponential Growth, logistic growth, Maximum sustainable yield

1.3 Disaster Management: Types of disasters (Natural & Man-made), Floods, Earthquake, Tsunamis, Cyclones, landslides (cause, effect & control)

1.4 Ecology & Ecosystem: Elements of ecology, definition of ecosystem- components types and function, Food chain & Foodweb,

Structure and function of the following ecosystem: Forest ecosystem, Grassland ecosystem, Desert ecosystem, Aquatic ecosystems

1.5 Environmental Management: Environmental impact assessment, Environmental laws and protection act of India, Different international environmental agreement.

2. Air pollution and control

6L

2.1 Sources of Pollutants: point sources, nonpoint sources and manmade sources primary & secondary pollutant

2.2 Types of air pollutants: primary & secondary pollutant ; Suspended particulate matter, oxides of carbon, oxides of nitrogen, oxides of sulphur, particulate, PAN, Smog (Photochemical smog and London smog),

2.3 Effects on human health & climate: Greenhouse effect, Global Warming, Acid rain, Ozone Layer Depletion

2.4 Air pollution and meteorology: Ambient Lapse Rate, Adiabatic Lapse Rate, Atmospheric stability & Temperature inversion

2.5 control of air pollution (ESP, cyclone separator, bag house, catalytic converter, scrubber (ventury),

3. Water Pollution

6L

3.1 Classification of water (Ground & surface water)

3.2 Pollutants of water, their origin and effects: Oxygen demanding wastes, pathogens, nutrients, Salts, heavy metals, pesticides, volatile organic compounds.

3.3 Surface water quality parameters: pH, DO, 5 day BOD test, BOD reaction rate constants, COD. Numerical related to BOD

Lake: Eutrophication [Definition, source and effect].

3.4 Ground water: Aquifers, hydraulic gradient, ground water flow (Definition only), ground water pollution (Arsenic & Fluoride; sources, effects, control)

3.5 Quality of Boiler fed water: DO, hardness, alkalinity, TDS and Chloride

3.7 Layout of waste water treatment plant (scheme only).

4. Land Pollution

2L

4.1 Types of Solid Waste: Municipal, industrial, commercial, agricultural, domestic, hazardous solid wastes (bio-medical), E-waste

4.2 Solid waste disposal method: Open dumping, Land filling, incineration, composting, recycling (Advantages and disadvantages).

5. Noise Pollution

2L

5.1 Definition of noise, effect of noise pollution on human health,

5.2 Average Noise level of some common noise sources

5.3 Definition of noise frequency, noise pressure, noise intensity, noise threshold limit value, equivalent noise level, L_{10} (18 hr Index).

5.4 Noise pollution control.

References/Books

1. A Textbook of Environmental Studies, Shashi Chawla. Tata McGraw Hill Education Private Limited
2. Environmental Studies, Dr. J P Sharma, University Science Press
3. Environmental Engineering, J K Das Mohapatra, Vikas Publication
- 4.

CO-PO matrices of courses HU401

	PO1	PO2	PO3	PO4	PO5	PO6	PO7	PO8	PO9	P10	P11	P12
HU401.1	3	2	3	-	-	-	3	-	-	-	1	2
HU401.2	-	-	1	-	-	-	-	-	-	-	-	-
HU401.3	2	-	2	-	1	-	2	-	-	-	-	-
HU401.4	-	-	2	-	-	2	2	-	-	-	-	-

Paper Name: Computer Architecture

Paper Code: CS401

Contact Hours/Week: 3

Credit: 3

Total Contact Hours: 36L

Perquisite

Digital Electronics and Computer Organization

Objective(s)

- To learn the basics of stored program concepts.
- To learn the principles of pipelining.

- To learn mechanism of data storage
- To distinguish between the concepts of serial, parallel, pipeline architecture.

Outcome(s)

CS401.1 Learn pipelining concepts with a prior knowledge of stored program methods

CS401.2 Learn about memory hierarchy and mapping techniques.

CS401.3 Study of parallel architecture and interconnection network.

Module – 1: [5L]

Introduction-

Introduction to basic computer architecture [1L]

Stored Program Concepts: Von Neumann & Harvard Architecture [1L]

RISC VS CISC[1L]

Amdahl's law. [1L]

Performance Measure: MIPS, Benchmark Programs(SPECINT,SPECFP).[1L]

Module – 2: [6L]

Pipelining-

Pipelining: Basic concepts, Linear vs. Non Linear, Static vs. Dynamic, Unifunction vs. Multifunction [2L]

Instruction Pipeline [1L]

Arithmetic pipeline [1L]

Hazards: Data hazards, control hazards and structural hazards[1L]

Techniques for handling hazards [1L]

Module – 3:[4L]

Instruction-level parallelism-

Instruction-Level Parallelism: Basic Concepts [1L]

Techniques For Increasing ILP, Superscalar, Super Pipelined [1L]

VLIW Processor Architectures [1L]

Array and Vector Processors [1L]

Module – 4:[5L]

Memory Hierarchy: Internal Memory, Main Memory, Cache Memory, Secondary memory[2L]

Mapping Technique in cache memory: Direct, Full Associative and Set Associative[2L]

Performance Implementation in Cache Memory.[1L]

Module – 5:[16L]

Multiprocessor architecture-

Introduction to Parallel Architecture-Different Classification scheme, Performance of Parallel Computers, PRAM model(EREW,CREW,CRCW) [6L]
 Interconnection Network(Omega,Baseline,Butterfly,Crossbar)[6L]
 Multi-Core Processor with case study(INTEL)[2L]
 Different Classification scheme:Serial Vs. Parallel, Pipeline vs. Parallel [2L]

Text Book:

1. Patterson D.A. and Hennessy , J.L. -Computer architecture a quantitative approach, 2nd ed., Morgan Kaufman, 1996
4. Stone, H.S., -Advanced Computer, Addison Wesley, 1989
5. Siegel, H.J., -Interconnection Network for Large Scale parallel Processing, 2nd Ed., McGraw Hill, 1990

Reference Book:

1. Hwang & Briggs—Computer Architecture & Parallel Processing, TMH
2. Hayes J. P., -Computer Architecture & Organisation, McGraw Hill
3. Design and Analysis of Parallel Algorithm-Schim G. Akl

CO & PO Mapping												
CO \ PO	PO1	PO2	PO3	PO4	PO5	PO6	PO7	PO8	PO9	PO10	PO11	PO12
CS401.1	3	2	-	1	-	-	-	-	-	-	-	-
CS401.2	3	-	2	-	-	-	-	-	-	-	-	-
CS401.3	2	-	2	-	-	-	-	-	-	-	-	-

Design & Analysis of Algorithm

Code: CS402

Contact: 3L/Week

Credits: 3

Total Contact hour: 36L

Perquisite

Data Structures

Objective(s)

The aim of this module is to learn how to develop efficient algorithms for simple computational tasks and reasoning about the correctness of them. Through the complexity measures, different range of behaviors of algorithms and the notion of tractable and intractable problems will be understood.

Outcome(s)

- CS402.1** Understand basic ideas about algorithms
- CS402.2** Apply design principles and concepts to algorithm design
- CS402.3** Analyze the efficiency of algorithms using time and space complexity theory.
- CS402.4** Develop efficient algorithms for simple computational tasks
- CS402.5** Implement algorithms in complex real life problems.

Module 1

Complexity Analysis:[2L]

Time and Space Complexity, Different Asymptotic notations – their mathematical significance. Recurrence relations: Solving with generating functions. Master Theorem and its illustrations.

Lower bound theory: $O(n \log_2 n)$ bound for comparison sorting algorithms.

Module 2

Algorithm Design Techniques:

Divide and Conquer: [3L]

Basic concepts with Examples for – Binary Search, Merge Sort, Quick Sort and their complexity (all three cases) Multiplication of two or more large numbers and its time complexity.

Dynamic Programming: [3L]

Basic concepts with Examples for – Matrix Chain Multiplication, Longest Common Subsequence problem, 0/1 knapsack problem.

Greedy Method: [3L]

Basic concepts with Examples for – Coin change problem, Job sequencing with deadlines, Huffman encoding and decoding.

Backtracking:

Basic concepts with Examples – 8 queens problem, Graph colouring problem.[2L]

Amortized analysis: aggregate, accounting, and potential methods.[1L]

Module 3

Advanced Data structures: Binomial heaps, Fibonacci heaps.[2L]

Disjoint set manipulation: [2L]

Set manipulation algorithm like UNION-FIND, union by rank.

Module 4

CS402.2		2	3								2	1
CS402.3			3								3	1
CS402.4			3								3	1
CS402.5			3								3	1

Paper: Formal Language and Automata Theory

Code: CS403

Contacts: 3L/Week

Credits: 3

Total Lectures: 35L

Prerequisites:

1. Digital Logic
2. Computer organization
3. Computer Fundamentals

Objective(s)

- Be able to construct finite state machines and the equivalent regular expressions.
- Be able to prove the equivalence of languages described by finite state machines and regular expressions.
- Be able to construct pushdown automata and the equivalent context free grammars.
- Be able to prove the equivalence of languages described by pushdown automata and context free grammars.
- Be able to construct Turing machines and Post machines.
- Be able to prove the equivalence of languages described by Turing machines and Post machines

Outcome(s)

CS403.1 To acquire the knowledge of the basics of state machines with or without output and its different classifications

CS403.2 To understand synchronous sequential circuits as the foundation of digital system.

CS403.3 To apply techniques of designing grammars and recognizers for several programming languages.

CS403.4 To analyze Turing's Hypothesis as a foreword to algorithms.

CS403.5 To perceive the power and limitation of a computer, and take decisions on computability.

Module-1: [9 L]

Fundamentals: Basic definition of sequential circuit, block diagram, mathematical representation, concept of transition table and transition diagram (Related to Automata concept of sequential circuit concept) Design of sequence detector [2L]

Introduction to Finite State Model (FSM), Finite State Machine, Finite Automata, Deterministic Finite Automata (DFA) and Non-deterministic Finite Automata (NFA), Transition diagrams, Transition tables and Language recognizers. [2L]

NFA with empty transitions, Equivalence between NFA with and without empty transitions. NFA to DFA conversion. [2L]

Minimization of FSM: Minimization Algorithm for DFA, Myhill-Nerode Theorem (proof not required) [2L]

Limitations of FSM, Application of Finite Automata [1L]

Module-2: [7 L]

Finite Automata with output – Moore & Mealy machine. Representation of Moore & Mealy Machine, Processing of the String through Moore & Mealy Machine, Equivalence of Moore & Mealy Machine – Inter-conversion. [2L]

Equivalent states and Distinguishable States, Equivalence and k-equivalence, Minimization of Mealy Machine [1L]

Minimization of incompletely specified machine – Merger Graph, Merger Table, Compatibility Graph [2L]

Lossless and Lossy Machine – Testing Table, Testing Graph [2L]

Module-3: [5 L]

Regular Languages, Regular Sets, Regular Expressions, Algebraic Rules for Regular Expressions, Arden's Theorem statement and proof [1L]

Constructing Finite Automata (FA) for given regular expressions, Regular string accepted by FA [2L]

Constructing Regular Expression for a given Finite Automata [1L]

Pumping Lemma of Regular Sets. Closure properties of regular sets (proofs not required). [1L]

Module-4: [9 L]

Grammar Formalism - Context Free Grammars, Derivation trees, sentential forms. Right most and leftmost derivation of strings, Parse Tree, Ambiguity in context free grammars. [1L]

Minimization of Context Free Grammars. [1L]

Chomsky normal form and Greibach normal form. [1L]

Pumping Lemma for Context Free Languages. [1L]

Enumeration of properties of CFL (proofs omitted). Closure property of CFL, Ogden's lemma & its applications [1L]

Regular grammars – right linear and left linear grammars [1L]

Practical

Subject Name: Numerical Methods and Statistics Lab

Subject Code: M (CSE) 491

Year: Second

Contact Hours: 3P/Week

Credit: 2

Prerequisite: Any introductory course on C/ Matlab.

Course Objective: The purpose of this course is to provide basic programming skills for solving the problems in numerical methods and statistics.

Course outcome(s)

On successful completion of the learning sessions of the course, the learner will be able to:

M(CSE)491.1 Apply the programming skills to solve the problems using multiple numerical approaches and statistics.

M(CSE)491.2 Analyze the results to design reports by effective presentation.

Experiments

1. Assignments on Newton forward /backward, Lagrange's interpolation.
2. Assignments on numerical integration using Trapezoidal rule, Simpson's 1/3 rule, Weddle's rule.
3. Assignments on numerical solution of a system of linear equations using Gauss elimination, Gauss Jacobi and Gauss-Seidel iterations.
4. Assignments on numerical solution of Algebraic Equation by Bisection method, Regula-Falsi, Newton-Raphson method.
5. Assignments on ordinary differential equation: Euler's method, Euler's modified method, Runge-Kutta methods.
6. Simple problems as assignment on Measures of Central Tendency- mean, median, mode, Measures of Dispersion- variance, standard deviation. Problems related to engineering field.

Implementation of numerical methods on computer through C/C++ and commercial Software Packages: Matlab / Scilab / Labview / Mathematica/NAG ([Numerical Algorithms Group](#)/Python).

PO \ CO	PO1	PO2	PO3	PO4	PO5	PO6	PO7	PO8	PO9	P10	P11	P12
M(CS) 491.1	2	1	-	-	3	-	-	-	-	-	-	1

Subject Name: Algorithms Lab

Subject Code: CS492

Contact Hours: 3P/Week

Credits: 2

Prerequisite

Computer Fundamental and Principles of Computer Programming

Course Objective(s)

In this laboratory after completing experiments student has to learn how to analyze a problem & design the solution for the problem. In addition to that, solution must be optimum, i.e., time complexity & memory usage of the solution must be very low.

Course Outcome(s)

CS492.1	Understand how several fundamental algorithms work particularly those concerned with Stack, Queues, Trees and various Sorting algorithms.
CS492.2	Understand different algorithm approach for problem solving.
CS492.3	Apply different algorithm approach to solve a problem.
CS492.4	Analyze the space & time efficiency of most algorithms
CS492.5	Design and Implement new algorithms or modify existing ones for new applications.

Write the following problems in any programming language. Programming Language used: C

1. Divide and Conquer:

- Implement Binary Search (Recursive & Iterative) using Divide and Conquer approach
- Implement Merge Sort using Divide and Conquer approach
- Implement Quick Sort using Divide and Conquer approach
- Find Maximum and Minimum element from a array of integer using Divide and Conquer approach
- Implement Multiplication of two large numbers

2. Heap sort:

Implement Heap Sort using Divide and Conquer approach

3. Dynamic Programming:

- Find the minimum number of scalar multiplication needed for chain of matrix
- Implement all pair of Shortest path for a graph (Floyd Warshall Algorithm)
- Implement Single Source shortest Path for a graph (Dijkstra , Bellman Ford)
- Implement Longest Common Subsequence problem

4. Brunch and Bound:

- Implement 15 Puzzle Problems

5. Backtracking:

- a. Implement 8 Queen Problem
- b. Graph Colouring Problem

5. Greedy method:

- a. Job sequencing with deadlines
- b. Minimum Cost Spanning Tree by Prim's Algorithm

Minimum Cost Spanning Tree by Kruskal's Algorithm

PO \ CO	PO1	PO2	PO3	PO4	PO5	PO6	PO7	PO8	PO9	P10	P11	P12
CS492.1	3	-	2	-	-	-	-	-	-	-	-	-
CS492.2		2	-	-	-	-	-	-	-	-	-	-
CS492.3	-	-	-	-	-	-	-	-	-	-	2	-
CS492.4	-	-	-	-	-	-	-	-	-	2	-	-
CS492.5	3	-	2	-	-	-	-	-	-	-	-	1

Subject Name: Programming with C++ Lab

Subject Code: CS493

Contact: 3P(1L+2P)/Week

Credits: 2

Perquisite

1. Computer Fundamentals and principles of computer programming

Course Objective(s)

- At the end of the course students should be familiar with the main features of the C++ language.
- Be able to write a C++ program to solve a well specified problem.
- Understand a C++ program written by someone else.
- Be able to debug and test C++ programs;
- Understand how to read C++ doc library documentation and reuse library code.
- To make the students understand the features of object oriented principles and familiarize them with virtual functions, templates and exception handling.
- To make the students to develop applications using C++.

Course Outcome

CS493.1 Students will be able to apply the computer programming techniques to solve practical problems.

493.2 Students will be able to understand the concepts and implementation of constructors and destructors.

CS493.3 Students will be able to develop software applications using object oriented programming language in C++

CS493.4 Students are able to learn C++ data types, memory allocation/deallocations, functions and pointers.

CS493.5 Students are able to apply object oriented programming concepts to software problems in C++ Outcome(s)

Experiments

1. Object-Oriented Programming Concepts: Introduction, comparison between procedural programming paradigm and object-oriented programming paradigm, basic concepts of object-oriented programming — concepts of an object and a class, interface and implementation of a class, operations on objects, relationship among objects, abstraction, encapsulation, data hiding, inheritance, overloading, polymorphism, messaging. [2]

2. Standard Input/Output: Concept of streams, hierarchy of console stream classes, input/output using overloaded operators >> and << and member functions of i/o stream classes, formatting output, formatting using ios class functions and flags, formatting using manipulators. [3]

3. Classes and Objects: Specifying a class, creating class objects, accessing class members, access specifiers, static members, use of *const* keyword, friends of a class, empty classes, nested classes, local classes, abstract classes, container classes, bit fields and classes. [4]

4. Pointers and Dynamic Memory Management: Declaring and initializing pointers, accessing data through pointers, pointer arithmetic, memory allocation (static and dynamic), dynamic memory management using *new* and *delete* operators, pointer to an object, *this* pointer, pointer related problems - dangling/wild pointers, null pointer assignment, memory leak and allocation failures. [5]

5. Constructors and Destructors: Need for constructors and destructors, copy constructor, dynamic constructors, explicit constructors, destructors, constructors and destructors with static members, initializer lists. [2]

6. Operator Overloading and Type Conversion: Overloading operators, rules for overloading operators, overloading of various operators, type conversion - basic type to class type, class type to basic type, class type to another class type. [4]

7. Inheritance: Introduction, defining derived classes, forms of inheritance, ambiguity in multiple and multipath inheritance, virtual base class, object slicing, overriding member functions, object composition and delegation, order of execution of constructors and destructors. [5]

8. Virtual functions & Polymorphism: Concept of binding - early binding and late binding, virtual functions, pure virtual functions, abstract classes, virtual destructors. [3]

9. Exception Handling: Review of traditional error handling, basics of exception handling, exception handling mechanism, throwing mechanism, catching mechanism, rethrowing an exception, specifying exceptions. [2]

10. Templates and Generic Programming: Template concepts, Function templates, class templates, illustrative examples. [3]

11. Files: File streams, hierarchy of file stream classes, error handling during file operations, reading/writing of files, accessing records randomly, updating files. [3]

PO \ CO	PO1	PO2	PO3	PO4	PO5	PO6	PO7	PO8	PO9	P10	P11	P12
CS493.1	3	-	2	-	-	-	-	-	-	-	-	-
CS493.2		2	-	-	-	-	-	-	-	-	-	-
CS493.3	-	-	-	-	-	-	-	-	-	-	2	-
CS493.4	-	-	-	-	-	-	-	-	-	2	-	-
CS493.5	3	-	2	-	-	-	-	-	-	-	-	1

Suggested Readings/ Books:

1. Lafore R., **Object Oriented Programming in C++**, Waite Group.
2. E. Balagurusamy, **Object Oriented Programming with C++**, Tata McGraw Hill.
3. R. S. Salaria, **Mastering Object-Oriented Programming with C++**, Salaria Publishing House.
4. Bjarne Stroustrup, **The C++ Programming Language**, Addison Wesley.
5. Herbert Schildt, **The Complete Reference to C++ Language**, McGraw Hill-Osborne.
6. R. S. Salaria, **Test Your Skills in Object-Oriented Programming With C++**, Salaria Publishing House.

PO \ CO	PO 1	PO2	PO3	PO4	PO5	PO6	PO7	PO8	PO9	P10	P11	P12
CS493.1	3	2	-	-	-	-	-	-	-	-	-	1
CS493.2	3	2	-	-	-	-	-	-	-	-	-	1
CS403.3	3	2	2	-	-	-	-	-	-	-	-	1
CS493.4	3	3	2	-	-	-	-	-	-	-	-	-
CS493.5	2	3	1	-	-		-	-	-	-	-	1

Department of Computer Science and
Engineering

Curriculum Structure

&

Syllabus

2016-2017

(Autonomy)

of

5th Semester

SL No	Type	Code	5TH SEMESTER					Cr. Points
			A. THEORY				Contact hours	
			L	T	P	Total		
1	PC	CS501	Computer Graphics	3	0	0	3	3
2	PC	CS502	Operating System	3	0	0	3	3
3	HS	HU 503	Economics for Engineers	2	0	0	2	2
4	PC	CS503	Data Base Management System	3	0	0	3	3
5	FE	CS(IT)504A	Object Oriented Programming using Java	3	0	0	3	3
		CS(IT)504B	Multimedia Technology					
		CS(ECE)504C	Communication Engineering					
6	PE	CS505A	Operations Research	3	0	0	3	3
		CS505A	Computational Geometry					
		CS505A	Digital Signal Processing					
Total Theory							17	17
			<u>B. PRACTICAL</u>					
7	PC	CS591	Computer Graphics Lab	0	0	3	3	2
8	PC	CS592	Operating System Lab	0	0	3	3	2
9	PC	CS 593	Data Base Management System Lab	0	0	3	3	2
10	FE	CS(IT)594A	Object Oriented Programming Lab	0	0	3	3	2
		CS(IT)594B	Multimedia Technology Lab					
		CS(ECE)594C	Communication Engineering Lab					
Total Practical							12	8
			<u>C. MANDATORY COURSES</u>					
11	MC	MC581	General Aptitude /Foreign Language	0	0	3	3	2 Unit
Total							32	25

Syllabus

Theory

Computer Graphics

Code : CS501

Contact : 3L/Week

Credits : 3

Allotted Hrs : 36L

Prerequisites:

1. Mathematics – I,III
2. Computer Fundamentals & Principle of Computer Programming
3. Programming with C++

Course Objective(s)

- To provide comprehensive introduction about computer graphics system, design algorithms and two dimensional transformations.
- To make the students familiar with techniques of clipping, three dimensional graphics and three dimensional transformations.
- The computer graphics course prepares students for activities involving in design, development and testing of modeling, rendering, and shading.

Course Outcome(s)

CS501.1 To know the foundations of computer graphics.

CS501.2 To comprehend the concept of geometric, mathematical and algorithmic concepts necessary for programming computer graphics

CS501.3 To understand the comprehension of windows, clipping and view-ports object representation in relation to images displayed on screen.

CS501.4 To recognize the software utilized in constructing computer graphics applications.

Course Contents

Module I

Introduction to computer graphics [3L]

Overview of computer graphics, Basic Terminologies in Graphics, direct coding, lookup table, 3D viewing devices, Plotters, printers, digitizers, Light pens etc.; Active & Passive graphics devices; Computer graphics software

Display [3L]

Light & Color models, Raster refresh displays, CRT basics, video basics, Flat panel displays, interpolative shading model; Texture

Module II

Scan conversion: [8L]

Points & lines, Line drawing algorithms; DDA algorithm, Bresenham's line algorithm, Circle generation algorithm

Ellipse generating algorithm; scan line polygon, fill algorithm, boundary fill algorithm, flood fill algorithm

Module III

2D and 3D Transformation [12L]

Basic transformations: translation, rotation, scaling ; Matrix representations & homogeneous coordinates, transformations between coordinate systems; reflection shear; Transformation of points, lines, parallel lines, intersecting lines

3D transformations: translation, rotation, scaling & other transformations. Rotation about an arbitrary axis in space, reflection through an arbitrary plane; general parallel projection transformation

2D and 3D Viewing & Clipping [4L]

Viewing pipeline, Window to viewport co-ordinate transformation, clipping operations, point clipping, line clipping, clipping circles, polygons & ellipse. Viewport clipping, 3D viewing.

Module IV

Curves [3L]

Curve representation, surfaces, designs, Bezier curves, B-spline curves, end conditions for periodic B-spline curves, rational B-spline curves

Hidden Surface Removal [3L]

Depth comparison, Z-buffer algorithm, Back face detection, BSP tree method, the Painter's algorithm, scan-line algorithm; Hidden line elimination, wire frame methods , fractal - geometry

Books:

1. Hearn, Baker – –Computer Graphics (C version 2nd Ed.) – Pearson education
2. Z. Xiang, R. Plastock – — Schaum’s outlines Computer Graphics (2nd Ed.) – TMH
3. D. F. Rogers, J. A. Adams – –Mathematical Elements for Computer Graphics (2nd Ed.) – TMH
4. Computer Graphics (OXFORD) ,Samit Bhattacharya.

CO-PO Mapping

	PO1	PO2	PO3	PO4	PO5	PO6	PO7	PO8	PO9	PO10	PO11	PO12
CO1		3										2
CO2	3	3		2								
CO3	2				3							
CO4			3	2								

Paper Name: Operating System

Paper Code: CS502

Contact Hours: 3/Week

Credit: 3

Total Contact Hours: 32L

Prerequisites:

4. Computer organization
5. Computer Architecture
6. Data Structures

Algorithms & Programming Concept

Objective(s)

1. To understand the services provided by and the design of an operating system.
2. To understand the structure and organization of the file system.
3. To understand what a process is and how processes are synchronized and scheduled.
4. To understand different approaches to memory management.
5. Students should be able to use system calls for managing processes, memory and the file system.
6. Students should understand the data structures and algorithms used to implement an OS.

Outcome(s)

CS502.1 Describe how computing resources such as CPU, memory and I/O are managed by the operating system.

CS502.2 Analyze kernel and user mode in an operating system.

CS502.3 Solve different CPU scheduling problem to achieve specific scheduling criteria.

CS502.4 Apply the knowledge of process management, synchronization, deadlock to solve basic problems.

CS502.5 Evaluate and report appropriate design choices when solving real-world problems

Course Content

Module – 1: [3L]

Functionalities of Operating System, Evolution of Operating System.

Types of Operating System: batch, multi-programmed, time-sharing, real-time, distributed, parallel, Structural overview, Protection & Security. [3L]

Module – 2: [9L]

Processes: Concept of processes, process states, PCB, process scheduling, co-operating processes, independent process, suspended process, Interaction between processes and OS, Inter-process communication: Message passing. [2L]

Threads: overview, benefits of threads, user and kernel level threads, Thread models. [2L]

CPU scheduling: scheduling criteria, preemptive & non-preemptive scheduling, scheduling algorithms (FCFS, SJF, SRTF, RR, priority, multilevel queue, multilevel feedback queue scheduling). [5L]

Module – 3:[9L]

Process Synchronization: background, critical section problem, synchronization hardware, classical problems of synchronization (producer-consumer, readers-writer, dining philosophers, etc), semaphores, monitors.

[5L]

Deadlocks: deadlock characterization, methods for handling deadlocks, deadlock prevention, deadlock avoidance, deadlock detection, recovery from deadlock. [4L]

Module – 4: [6L]

Background, logical vs. physical address space, swapping, contiguous memory allocation, paging, Segmentation, TLB. [3L]

Virtual Memory: background, demand paging, page replacement algorithms (FCFS, LRU, Optimal), thrashing, Working set model. [3L]

Module – 5:[5L]

Disk structure, disk scheduling (FCFS, SSTF, SCAN,C-SCAN,LOOK,C-LOOK etc),disk reliability, disk formatting, boot block, bad blocks. [2L]

File: File concept, access methods, directory structure, file system structure, UNIX file structure, allocation methods (contiguous, linked, indexed), free-space management (bit vector). [2L]

I/O: I/O hardware, polling, interrupts, DMA, caching, buffering, blocking-non blocking I/O. [1L]

Text Book:

1. Abraham Silberschatz, Peter B. Galvin, Greg Gagne, Operating System Concepts.
2. *Operating Systems& Systems Programming* by P Balakrishna Prasad

Reference Book:

1. Dietel H. N., -An Introduction to Operating Systems|, Addison Wesley.

CO & PO Mapping												
	PO1	PO2	PO3	PO4	PO5	PO6	PO7	PO8	PO9	PO10	PO11	PO12
CO1	✓	✓			✓							✓
CO2	✓	✓										✓
CO3	✓	✓					✓					✓
CO4	✓	✓					✓					✓
CO5	✓	✓				✓						✓

2. Andrew Tanenbaum, Modern Operating Systems, Prentice Hall.
3. William Stallings, Operating Systems, Prentice Hall.

Paper Name: Economics for Engineers

Paper Code: HU503

Contact: L-T-P = 2 – 0 – 0

Credit: 2

Pre-requisites:MATH – College Algebra, Pre-Calculus Algebra and Trigonometry.

Course Objective: This course emphasizes the strong correlation between engineering design and manufacturing of products/systems and the economic issues they involve.

Course Outcome:

1. Apply the appropriate engineering economics analysis method(s) for problem solving: present worth, annual cost, rate-of-return, payback, break-even, benefit-cost ratio.
2. Evaluate the cost effectiveness of individual engineering projects using the methods learned and draw inferences for the investment decisions.
3. Compare the life cycle cost of multiple projects using the methods learned, and make a quantitative decision between alternate facilities and/or systems.
4. Evaluate the profit of a firm, carry out the break even analysis and employ this tool to make production decision.
5. Discuss and solve advanced economic engineering analysis problems including taxation and inflation.

Course Content:

MODULE I Introduction

3L

Managerial Economics-Relationship with other disciplines-Firms: Types, Objectives and goals-Managerial Decisions-Decision Analysis.

MODULE II Demand and Supply Analysis

10 L

Demand-Types of demand-determinants of demand-Demand function-Demand Elasticity-Demand forecasting-Supply-Determinants of supply-Supply function-Supply Elasticity.

MODULE III Cost Analysis

10 L

Element of costs, Marginal cost, Marginal Revenue, Sunk cost, Opportunity cost, Break-even analysis – PV ratio,

MODULE IV Elementary economic Analysis –

06 L

Inflation-Meaning of inflation, types, causes, measures to control inflation. National Income-Definition, Concepts of national income, Method of measuring national income.

MODULEV: Financial Accounting

08 L

Concepts and Definition of Accounting,Journal,Ledger,Trial Balance. TradingA/C,Profit & Loss A/C and Balance Sheet.

MODULE VI : Investment Decision

04L

Time value of money- Interest - Simple and compound, nominal and effective rate of interest, Cash flow diagrams, Principles of economic equivalence. Evaluation of engineering projects-Present worth method, Future worth method, Annual worth method, Internal rate of return method, Cost benefit analysis for public projects .

Text Books

1. Riggs, Bedworth and Randhwa, -Engineering Economics, McGraw Hill Education India
2. Principles of Economics, Deviga Vengedasalam; Karunagaran Madhavan, Oxford University Press.
3. Engineering Economy by William G.Sullivan, Elin M.Wicks, C. Patric Koelling, Pearson
4. R.Paneer Seelvan, — Engineering Economics, PHI
5. Ahuja,H.L., -Principles of Micro Economics, S.Chand & Company Ltd
6. Jhingan,M.L., -Macro Economic Theory
7. Macro Economics by S.P.Gupta, TMH
8. Haniff and Mukherjee,Modern Accounting,Vol-1,TMG
- 9.Modern Economic Theory – K.K. Dewett (S.Chand)

CO-PO MAPPING

	PO1	PO2	PO3	PO4	PO5	PO6	PO7	PO8	PO9	PO10	PO11	PO12
CO1											√	
CO2				√								
CO3											√	
CO4									√			
CO5											√	

DATABASE MANAGEMENT SYSTEM

Code: CS503

Contact Hours: 3L /Week

Credits: 3

Prerequisite:

1. Logic of programming language
2. Basic concepts of data structure and algorithms

Course Objectives

1. To learn the data models, conceptualize and depict a database system
2. To design system using E-R diagram.
3. To learn SQL & relational database design.
4. To understand the internal storage structures using different file and indexing techniques.
5. To know the concepts of transaction processing, concurrency control techniques and recovery procedure.

Course Outcomes(COs)

On completion of the course students will be able to

CS503.1 Apply the knowledge of Entity Relationship (E-R) diagram for an application.

CS503.2 Create a normalized relational database model

CS503.3 Analyze real world queries to generate reports from it.

CS503.4 Determine whether the transactions satisfy the ACID properties.

CS503.5 Create and maintain the database of an organization..

Module 1:

Introduction [3L]

Concept & Overview of DBMS, Data Models, Database Languages, Database Administrator, Database Users, Three Schema architecture of DBMS.

Module 2:

Entity-Relationship and Relational Database Model [11L]

Basic concepts, Design Issues, Mapping Constraints, Keys, Entity-Relationship Diagram, Weak Entity Sets, Extended E-R features, case study on E-R Model. Structure of relational Databases, Relational Algebra, Relational Calculus, Extended Relational Algebra Operations, Views, Modifications Of the Database.

Module 3:

SQL and Integrity Constraints [6L]

Concept of DDL, DML, DCL. Basic Structure, Set operations, Aggregate Functions, Null Values, Domain Constraints, Referential Integrity Constraints, assertions, views, Nested Subqueries, Database security application development using SQL, Stored procedures and triggers.

Module 4:

Relational Database Design [8L]

Functional Dependency, Different anomalies in designing a Database., Normalization using functional dependencies, Decomposition, Boyce-Codd Normal Form, 3NF, Normalization using multi-valued dependencies, 4NF, 5NF , Case Study

Module 5:

Internals of RDBMS [9L]

Physical data structures, Query optimization: join algorithm, statistics and cost based optimization. Transaction processing, Concurrency control and Recovery Management: transaction model properties, state serializability, lock based protocols; two phase locking, Dead Lock handling

Module 6:

File Organization & Index Structures [6L]

File & Record Concept, Placing file records on Disk, Fixed and Variable sized Records, Types of Single-Level Index (primary, secondary, clustering), Multilevel Indexes

Text Books:

1. Henry F. Korth and Silberschatz Abraham, —Database System Concepts, Mc.Graw Hill.
2. Elmasri Ramez and Novathe Shamkant, —Fundamentals of Database Systems, Benjamin Cummings Publishing. Company.
3. Ramakrishnan: Database Management System , McGraw-Hill
4. Gray Jim and Reuter Address, -Transaction Processing : Concepts and Techniques, Moragan KauffmanPublishers.
5. Ullman JD., —Principles of Database Systems, Galgottia Publication.

Reference:

1. Jain: Advanced Database Management System CyberTech
2. Date C. J., -Introduction to Database Management, Vol. I, II, III, Addison Wesley.
3. —Fundamentals of Database Systems, Ramez Elmasri, Shamkant B.Navathe, Addison Wesley PublishingEdition
4. —Database Management Systems, Arun K.Majumdar, Pritimay Bhattacharya, Tata McGraw Hill

		CO & PO Mapping														
CO \ PO	PO	PO	PO	PO	PO	PO	PO	PO	PO	PO	PO10	PO11	PO12	PSO	PSO	PSO
	1	2	3	4	5	6	7	8	9				1	2	3	
CS503.1	2	2	2	2	3	2	1	1	2	2	3	3	2	2	1	
CS503.2	2	3	3	3	3	1	1	1	2	2	3	3	2	2	2	
CS503.3	3	3	2	3	3	2	2	2	3	3	3	3	3	2	2	
CS503.4	3	3	2	2	2	1	1	1	1	1	2	3	2	1	1	
CS503.5	3	3	3	3	3	2	2	2	3	3	3	3	3	2	2	
CS503 (average)	3	3	2	3	3	2	1	1	2	2	3	3	2	2	2	

Object Oriented Programming using Java

Code: CS(IT)504A

Contact: 3L/Week

Credits: 3

Total Lectures: 36

Prerequisites:

1. Computer Fundamentals & Principle of Computer Programming
2. Programming with C++

Course Objective(s)

- Be able to explain the difference between object oriented programming and procedural programming.
- Be able to program using more advanced C++ features such as composition of objects, operator overloads, dynamic memory allocation, inheritance and polymorphism, file I/O, exception handling, etc.
- Be able to build classes using appropriate encapsulation and design principles
- Be able to apply object oriented or non-object oriented techniques to solve bigger computing problems

Course Outcome(s)

CS(IT)504A.1 Design the process of interaction between Objects and System w.r.t. Object Oriented Paradigm.

CS(IT)504A.2 Acquire a basic knowledge of Object Orientation with different properties as well as different features of Java.

CS(IT)504A.3 Analyze basic programming concepts in Java with different object related issues and various string handling functions as well as basic I/O operations.

CS(IT)504A.4 Discuss basic Code Reusability concept w.r.t. Inheritance, Package and Interface

CS(IT)504A.5 Implement Exception handling, Multithreading and Applet (Web program in java) programming concept in Java

Course Contact

Module 1: [5L]

Introduction:

Object Oriented Analysis & Design-Concepts of object oriented programming language, Object, Class.[1L]; Relationships among objects and classes-Generalization, Specialization, Aggregation, Association, Composition, links, Meta-class. [1L] ; Object Oriented Programming concepts - Difference between OOP and other conventional programming – advantages and disadvantages. Class, object, Method. [1L]; Properties of OOP- message passing, inheritance, encapsulation, polymorphism, Data abstraction. [1L]; Difference between different OOPs Languages. [1L].

Module 2: [9L]

Java Basics:

Basic concepts of java programming - Advantages of java, Byte-code & JVM, Data types, Different types of Variables. [1L] ;Access specifiers, Operators, Control statements & loops.

[1L]; Array. [1L]; Creation of class, object, method. [1L]; Constructor- Definition, Usage of Constructor, Different types of Constructor. [1L]; finalize method and garbage collection, Method & Constructor overloading. [1L]; this keyword, use of objects as parameter & methods returning objects. [1L]; Call by value & call by reference. [1L]; Static variables & methods. Nested & inner classes. [1L].

Module 3:[4L]

Basic String handling & I/O :

Basic string handling concepts- Concept of mutable and immutable string, Methods of String class-charAt(), compareTo(), equals(), equalsIgnoreCase(), indexOf(), length(), substring(). [1L]; toCharArray(), toLowerCase(), toString(), toUpperCase(), trim(), valueOf() methods, Methods of String buffer class- append(), capacity(), charAt(), delete(), deleteCharAt(). [1L]; ensureCapacity(), getChars(), indexOf(), insert(), length(), setCharAt(), setLength(), substring(), toString(). [1L]; Command line arguments, basics of I/O operations – keyboard input using BufferedReader & Scanner classes. [1L].

Module 4: [8L]

Inheritance and Java Packages :

Inheritance - Definition, Advantages, Different types of inheritance and their implementation. [1L]; Super and final keywords, super() method. [1L]; Method overriding, Dynamic method dispatch. [1L]; Abstract classes & methods. [1L]; Interface - Definition, Use of Interface. [1L]; Multiple inheritance by using Interface. [1L]; Java Packages -Definition, Creation of packages. [1L]; Importing packages, member access for packages. [1L]

Module 5: [10L]

Exception handling, Multithreading and Applet Programming :

Exception handling - Basics, different types of exception classes. Difference between Checked & Unchecked Exception. [1L]; Try & catch related case studies.[1L]; Throw, throws & finally. [1L]; Creation of user defined exception. [1L]; Multithreading - Basics, main thread, thread life cycle.[1L]; Creation of multiple threads-yield(), suspend(), sleep(n), resume(), wait(), notify(), join(), isAlive().[1L]; Thread priorities, thread synchronization.[1L]; Interthread communication, deadlocks for threads[1L]; Applet Programming - Basics, applet life cycle, difference between application & applet programming[1L]; Parameter passing in applets. [1L]

Recommended Books:

Textbooks:

1. Herbert Schildt – "Java: The Complete Reference " – 9th Ed. – TMH
2. E. Balagurusamy – " Programming With Java: A Primer " – 3rd Ed. – TMH.

References:

1. R.K Das – " Core Java for Beginners " – VIKAS PUBLISHING.

- Rambaugh, James Michael, Blaha – " Object Oriented Modelling and Design " – Prentice Hall, India.

CO/PO Mapping												
CO \ PO	Programme Outcomes(POs)											
	PO1 K=3	PO2 K=4	PO3 K=5	PO4 K=6	PO5 K=6	PO6	PO7	PO8	PO9	PO10	PO11	PO12
CS(IT)504A.1	3	3	2									
CS(IT)504A.2	3	2										
CS(IT)504A.3	3	3	3				2		2			
CS(IT)504A.4			2									
CS(IT)504A.5					2				2	2	2	

Multimedia Technology
CS(IT)504B
Contact: 3L/Week
Credits: 3
Total Lectures: 36L

Prerequisites:

- Computer Fundamentals & Principle of Computer Programming
- Algorithms & Programming Concept

Objective(s)

- Discuss the technical details of common multimedia data formats, protocols, and compression techniques of digital images, video and audio content.
- Describe and understand the technical details of JPEG and MPEG families of standards.
- Discuss the significance of -Quality of Service in multimedia networking.
- Describe the principles and technical details of several wired and wireless networking protocols.
- Develop simple but demonstrative multimedia applications using JAI and JMF.

- Understand and describe technical aspects of popular multimedia web applications including VoD and VoIP.

Outcome(s)

- | | |
|---------------------|--|
| CS(IT)504B.1 | Identify different media; representations of different multimedia data and data formats. |
| CS(IT)504B.2 | Analyze various compression techniques. |
| CS(IT)504B.3 | Compare various audio and video file formats. |
| CS(IT)504B.4 | Apply different coding technique for solving real world problems. |
| CS(IT)504B.5 | Choose optical storage media suitable for multimedia applications. |

Module 1: Introduction, Text and Audio [6L]

Multimedia today, Impact of Multimedia, Multimedia Systems, Components and Its Applications.

Text: Types of Text, Ways to Present Text, Aspects of Text Design, Character, Character Set, Codes, Unicode, Encryption;

Audio: Basic Sound Concepts, Types of Sound, Digitizing Sound, Computer Representation of Sound (Sampling Rate, Sampling Size, Quantization), Audio Formats, Audio tools, MIDI.

Module 2: Image and Video (8L)

Image: Formats, Image Color Scheme, Image Enhancement; Lossless Compression: Huffman Coding Arithmetic and Lempel-Ziv Coding, Lossy Image Compression Systems: Theory of Quantization, Delta Modulation and DPCM, Transform Coding & K-L Transforms, Discrete Cosine Transforms

Video: Analogue and Digital Video, Recording Formats and Standards (JPEG, MPEG, H.261)

Transmission of Video Signals, Video Capture, and Computer based Animation.

Module 3: Synchronization, Multi-Resolution Analysis, Storage models and Access Techniques [8L]

Temporal relationships, synchronization accuracy specification factors, quality of service.

Magnetic media, optical media, file systems (traditional, multimedia)

Multimedia devices – Output devices, CD-ROM, DVD, Scanner, CCD

Theory of Wavelets, Theory of Subband Coding (z-transform), Multi-resolution Analysis: Discrete Wavelet Transforms.

Module 4: Image and Video Database (7L)

Image representation, segmentation, and similarity based retrieval, image retrieval by color, shape and texture; indexing- kd trees, R-trees, quad trees; Case studies- QBIC, Virage. Video Content, querying, video segmentation, indexing

Module 5: Embedded Wavelet Coding and Multimedia Applications (7L)

Zerotree Approach, SPIHT algorithm and EBCOT Algorithm.

Interactive television, Video-on-demand, Video Conferencing, Educational Applications, Industrial Applications, Multimedia archives and digital libraries, media editors.

Books:

1. Ralf Steinmetz and Klara Nahrstedt , Multimedia: Computing, Communications & Applications , Pearson Ed.
2. Nalin K. Sharda , Multimedia Information System , PHI.
3. Fred Halsall , Multimedia Communications , Pearson Ed.
4. Koegel Buford , Multimedia Systems , Pearson Ed.
5. Fred Hoffstetter , Multimedia Literacy , McGraw Hill.
6. Ralf Steinmetz and Klara Nahrstedt , Multimedia Fundamentals: Vol. 1- Media Coding and Content Processing , PHI.
7. J. Jeffcoate , Multimedia in Practice: Technology and Application , PHI.
8. Prabhat K. Andleigh & Kiran Thakrar , Multimedia Systems Design , PHI.

CO/PO Mapping												
PO	Programme Outcomes(POs)											
CO	PO1	P02	P03	PO4	P05	P06	P07	P08	P09	P010	P011	P012
CS(IT)504B.1	2	3										
CS(IT)504B.2		2										
CS(IT)504B.3		2	1									
CS(IT)504B.4		2	2									
CS(IT)504B.5	2	2	1									

Subject Name: Communication Engineering

Subject Code: CS(ECE)504C

Contact Hours: 3l/Week

Credits: 3

Prerequisites:

- Knowledge in different types of signals
- Exponential Fourier series
- Fourier transform and its properties
- Energy and power signal
- Probability and statistics

Course Objective(s)

To present the fundamentals of analog and modern digital communication system design. Students should evaluate the performance of analog and digital signaling schemes on realistic communication channels. Emphasis is placed on physical layer digital communications and coding techniques, including waveform analysis, transmitter design and receiver design. The student will learn about theoretical bounds on the rates of digital data transportation systems.

Course Outcome(s)

CS(ECE)504C.1 Apply the fundamental concepts of engineering principles in design issues in various communication systems.

CS(ECE)504C.2 Inspect recent trend and performance issues for different digital modulation techniques.

CS(ECE)504C.3 Demonstrate the concepts of sampling, Pulse Modulation techniques and their comparison.

CS(ECE)504C.4 Design Matched filter, demonstrate the effects of Inter Symbol Interference (ISI) and compare Eye pattern analysis.

CS(ECE)504C.5 Illustrate various types of coherent and non-coherent digital modulation techniques, analyze immunity parameters and calculate their error probabilities.

CS(ECE)504C.6 Apply the basic concepts for analyzing the modulation techniques including amplitude modulation (AM), frequency modulation (FM) and phase modulation (PM) that are widely used in analogue communication systems in the time and frequency domains

Course Content:

Module - 1: Elements of Communication system, Analog Modulation & Demodulation, Noise, SNR. (Basic ideas in brief) [10]

Introduction to Base Band transmission & Modulation (basic concept) (1L); Elements of Communication systems (mention of transmitter, receiver and channel); origin of noise and its effect, Importance of SNR in system design (1L); Basic principles of Linear Modulation (Amplitude Modulation, DSB-SC, SSB-SC and VSB) (4L); Basic principles of Non-linear modulation (Angle Modulation - FM, PM) (1L); Sampling theorem, Sampling rate, Impulse sampling, Reconstruction from samples, Aliasing (1L); Analog Pulse Modulation - PAM (Natural & flat topped sampling), PWM, PPM (1L). Multiplexing - TDM, FDM (1L).

Module - 2: Digital Transmission: [9]

Concept of Quantisation & Quantisation error, Uniform Quantiser (1L); Non-uniform Quantiser, A-law & μ -law companding (mention only) (1L); concept of Pulse Code Modulation ; Delta modulation, Adaptive delta modulation, DPCM (basic concept and importance only, no details) (2L); Encoding, Coding efficiency (1L); Line coding & properties, NRZ & RZ, AMI, Manchester coding (1L); Baseband Pulse Transmission, Matched filter (mention of its importance and basic concept only), Error rate due to noise (2L); ISI, Raised cosine function, Nyquist criterion for distortion-less base-band binary transmission, Eye pattern, (1L).

Module - 3: Digital Carrier Modulation & Demodulation Techniques: [5]

Bit rate, Baud rate (1L); M-ary encoding, Introduction to the different digital modulation techniques - ASK, FSK, PSK, BPSK, QPSK, mention of 8 BPSK, 16 BPSK (2L); Introduction to QAM, mention of 8QAM, 16 QAM without elaboration (1L); Spread Spectrum Modulation - concept only (1L).

Module - 4: Information Theory & Coding: [8]

Introduction, News value & Information content (1L); Entropy (1L); Mutual information (1L); Information rate (1L); The Shannon limit, Shannon-Fano algorithm for encoding (1L); Shannon's

Theorem - Source Coding Theorem (1L); Channel Coding Theorem, Information Capacity Theorem (basic understanding only) (1L); Error Control & Coding – basic principle only (1L)

Text Books:

1. An Introduction to Analog and Digital Communications by Simon Haykin; Published by Wiley India.
2. Principles of Communication Systems, H. Taub and D .L.Schilling, TMH Publishing Co.

References:

1. Communication Systems 4th Edition by Simon Haykin; Published by Wiley India (Student Edition).
2. Communication Systems by A. B. Carlson, Published by McGraw-Hill.
3. Modern Digital and Analog Communication Systems, B.P.Lathi and Z.Ding, Oxford University Press.
4. Principles and Analog and Digital Communication by Jerry D Gibson, Published by MacMillan.
5. Communications System (Analog and Digital) by Dr. Sanjay Sharma S K Kataria and Sons.

CO-PO Mapping:

CO & PO Mapping												
CO \ PO	PO1	PO2	PO3	PO4	PO5	PO6	PO7	PO8	PO9	PO10	PO11	PO12
CS(ECE)504C .1	3	3	3		1	1			2			3
CS(ECE)504C .2	3	3		3	3		2			1	2	3
CS(ECE)504C .3	3	3	3	3	2	2			1			3
CS(ECE)504C .4	3	3	3	2	3		2			2	2	3
CS(ECE)504C .5	3	3		3	3	2						3
CS(ECE)504C .6	3	3	3			2	2	3	1	2		3

Text Books:

1. An Introduction to Analog and Digital Communications by Simon Haykin; Published by Wiley India.
2. Principles of Communication Systems, H. Taub and D .L.Schilling, TMH Publishing Co.

References:

1. Communication Systems 4th Edition by Simon Haykin; Published by Wiley India (Student Edition).
2. Communication Systems by A. B. Carlson, Published by McGraw-Hill.
3. Modern Digital and Analog Communication Systems, B.P.Lathi and Z.Ding, Oxford University Press.
4. Principles and Analog and Digital Communication by Jerry D Gibson, Published by MacMillan.
5. Communications System (Analog and Digital) by Dr. Sanjay Sharma S K Kataria and Sons.

Subject Name: Operations Research

Subject Code: CS 505A

Contact Hours: 3L/Week

Credits: 3

Prerequisite: Basic Knowledge of Function, plotting of Equation and inequations, Formulation of Mathematical Problem. Finding maximum and minimum from row or column or from Matrix.

Course Objective

Purpose of this course to develop models and then analyze the model using the techniques of Operations Research, Decision making under uncertainty and risk.

Course Outcome(s)

- On successful completion of the learning sessions of the course, the learner will be able to:
- Recall the distinctive characteristics of different types of decision-making problem to formulate and solve a real-world problem a prototype of mathematical problem.
- Understand the theoretical workings of appropriate decision making approaches and tools to identify the optimal strategy in competitive world.
- Apply the principles of different Methods/Model of Operations Research to solve practical problems.

Module I

Linear Programming Problem(LPP): Basics of Linear Programming Problem(LPP) and its Applications. General Mathematical Formulation of LPP; Definitions: Convex set, Solution, Feasible Solution, Basic and Non-Basic Variables, Basic Feasible Solution, Degenerate and Non-Degenerate solution, Optimum/Optimal Solution; Solution of LPP by Graphical Analysis/Method, Simplex Method, Charnes' Big M-Method; Duality Theory. **4L+2L+2L=8L**

Module II

Transportation Problem, Assignment Problem.

5L

Module III

CS 505A.2	3	2	-	-	-	-	-	-	-	-	-	1
CS 505A.3	3	2	2	-	-	-	-	-	-	-	-	1

Subject Name: Computational Geometry

Subject Code: CS505B

Contact Hours: 3L/Week

Credits: 3

Prerequisites:

1. Mathematics-II
2. Algorithms & Programming Concept

Course Objective(s)

1. The objectives of this course are as follows:
2. Introduce rigorous algorithmic analysis for problems in Computational Geometry.
3. Discuss applications of Computational Geometry to graphical rendering.
4. Introduce the notions of Voronoi diagrams and Delaunay Triangulations.
5. Develop expected case analyses for linear programming problems in small dimensions.

Course Outcome(s)

1. Upon successful completion of this course, students will be able to:
2. Analyze randomized algorithms for small domain problems.
3. Use line-point duality to develop efficient algorithms.
4. Apply geometric techniques to real-world problems in graphics.
5. Solve linear programs geometrically.

Module 1:

CONVEXHULLS ALGORITHMS: Orientation test; Degeneracy; Jarvis' march, Divide & conquer; Graham's scan, Chan's algorithm. [6 hours].

PLANE-SWEEP ALGORITHMS:Line segment intersections (Plane-sweep), Doubly linked edge list, Overlay subdivisions, **Polygon Triangulation** (Triangulating monotone polygons, Partitioning simple polygons), **Convex Partitioning**(Lower and upper bounds, A factor 4 approximation algorithm). [8 hours]

Module 2:

LINEAR PROGRAMMING:Manufacturing with Molds (Necessary and Sufficient condition, Half-Plane Intersections), **Linear Programming** (Feasible Region, Optimal solution; Incremental and randomized algorithms) [6 Hours]

Paper Name: Digital Signal Processing

Paper Code: CS505C

Contacts: 3L /Week

Credits: 3

Total Contact: 35

Course Objective(s)

- To introduce student with the concept of signal, systems and sampling theorem.
- To study of convolution-sum or response of LTI system.
- To study the z-transform, convolution, correlation and applications of z -transform.
- To introduce students with transforms for analysis of discrete time signals and systems.
- To understand the digital signal processing, sampling and aliasing.
- To use and understand implementation of digital filters.
- To study filter design techniques.
- To study Discrete Fourier Transforms.
- To study Fast Fourier Transforms and application of DSP.

Course Outcome(s)

- Determine the spectral coefficients and the Fourier series components of discrete-time signals. Determine the frequency response and the z-transform of discrete-time systems.
- Determine the discrete Fourier transform of discrete-time signals.
- Calculate the outputs of discrete-time systems in response to inputs and design Finite Impulse Response (FIR) and Infinite Impulse Response (IIR) filters, and evaluate the
- Performance to meet expected system specifications using MATLAB.
- Demonstrate an understanding of contemporary issues by reviewing recent technical articles and establishing between the course material and the content of the article.

Module I: Discrete-time signals & LTI Systems:

[10L]

Concept of discrete-time signal, basic idea of sampling and reconstruction of signal, sampling theorem. sequences – periodic, energy, power, unit sample, unit-step, unit-ramp, real & complex exponentials, arithmetic operations on sequences.

Definition, representation, impulse response, derivation for the output sequence, concept of convolution, graphical, analytical and overlap-add methods to compute convolution supported with examples and exercises. Properties of convolution, interconnections of LTI systems with physical interpretations, stability and causality conditions.

Practical

Computer Graphics Lab

Code: CS 591

Contact: 3P/Week

Credits: 2

Prerequisites: Knowledge of C programming language

Course Objective(s)

- To understand the need of developing graphics application
- To learn algorithmic development of graphics primitives like: line, circle, polygon etc.
- To learn the representation and transformation of graphical images and pictures.

Course Outcome(s)

CS591.1	To draw Geometric primitives
CS591.2	To execute scan line polygon filling
CS591.3	To implement basic transformations on objects
CS591.4	To implement clipping algorithm on lines

Experiments

1. Study of basic graphics functions defined in `-graphics.h`.
2. Study of graphics standards like CORE, GKS (Graphics Kernel System), GKS3D (Graphics Kernel System -3 Dimensions), PHIGS (Programmer's Hierarchical Interactive Graphics Systems), CGM (Computer Graphics Metafile), CGI (Computer Graphics Interface).
3. Program to implement basic graphics primitives in OpenGL.
4. Program for Line Drawing using DDA algorithm using C and OpenGL.
5. Program for Line Drawing using Bresenham's algorithm using C and OpenGL.
6. Programs using 2-D transformations in C.
7. Implement Polygon filling algorithms [Flood-Fill Algorithm] in C.
8. Programs to study window to viewport transformations in C.
9. Program for Cohen Sutherland Line clipping algorithm in C.
10. Programs to study 3-D transformations in C.

PO CO	PO1	PO2	PO3	PO4	PO5	PO6	PO7	PO8	PO9	PO10	PO11	PO12
CO1	3				3							
CO2	3				3							
CO3	3		2		3							
CO4	3		2		3							

Paper Name: Operating Systems Lab

Code: CS 592

Contacts: 3P/Week

Credits: 2

Prerequisites:

1. Computer organization
2. Computer Architecture
3. Data Structures
4. Algorithms & Programming Concept

Course Objective(s)

- To familiarize the students with the Operating System.
- To demonstrate the process, memory, file and directory management issues under the UNIX/ LINUX operating system
- To introduce LINUX basic commands
- To make students how to make simple programs in LINUX and administrative task of LINUX

Course Outcome(s)

CS 592.1 Analyze different aspects of Linux.

CS 592.2 Create or design different scripts using shell programming.

CS 592.3 Implement process, thread, semaphore concept of operating system.

CS 592.4 Create shared memory with the implementation of reading from, write into shared

CO2		3	2	2											2
CO3	3			3											
CO4		3	2												2

Database Management System Lab

CS593

Contact: 3P/Week

Credits: 2

Prerequisite:

1. Logic of programming language
2. Basic concepts of data structure and algorithms

Course Objectives

1. To learn the data models, conceptualize and depict a database system
2. To learn the fundamental concepts of SQL queries.
3. To understand the concept of designing a database with the necessary attributes.
4. To know the methodology of Accessing, Modifying and Updating data & information from the relational databases
5. To learn database design as well as to design user interface and how to connect with database.

Course Outcome(s)

On completion of the course students will be able to

CS593.1 Understand the basic concepts regarding database, know about query processing and techniques involved in query optimization and understand the concepts of database transaction and related database facilities including concurrency control, backup and recovery.

CS593.2 Understand the introductory concepts of some advanced topics in data management like distributed databases, data warehousing, deductive databases and be aware of some advanced databases like partial multimedia and mobile databases.

CS593.3 Differentiate between DBMS and advanced DBMS and use of advanced database concepts and become proficient in creating database queries.

CS593.4 Analyze database system concepts and apply normalization to the database.

CS593.5 Apply and create different transaction processing and concurrency control applications.

CO #	PO 1	PO 2	PO 3	PO 4	PO 5	PO 6	PO 7	PO 8	PO 9	PO 10	PO 11	PO 12	PS O1	PS O2	PS O3
CS59 3.1	2	2	2	2	3	2	1	1	2	2	3	3	2	2	1

CS59 3.2	2	3	3	3	3	1	1	1	2	2	3	3	2	2	2
CS59 3.3	3	3	2	3	3	2	2	2	3	3	3	3	3	2	2
CS59 3.4	3	3	2	2	2	1	1	1	1	1	2	3	2	1	3
CS59 3.5	3	3	3	3	3	2	2	2	3	3	3	3	3	2	2

Text Book:

- 1) -SQL, PL/SQL the Programming Language of Oracle^{ll} by Ivan Bayross, BPB Publications
- 2) —Oracle Applications Development^{ll}, by Ivan Bayross, BPB Publications
- 3) -SQL The Complete Reference 3rd Edition^{ll}, by James Groff and Paul Weinberg, McGrawHill

Object Oriented Programming Lab

Code: CS(IT)594A

ContactHours : 3P/Week

Credits: 2

Practical Class allotted: 12 no of labs X 3=36

Prerequisite: Knowledge of C programming language

Course Objective(s)

- Understand fundamentals of programming such as variables, conditional and iterative execution, methods, etc.
- Understand fundamentals of object-oriented programming in Java, including defining classes, invoking methods, using class libraries, etc.
- Be aware of the important topics and principles of software development.
- Have the ability to write a computer program to solve specified problems.
- Be able to use the Java SDK environment to create, debug and run simple Java programs.

Course Outcome(s)

- Implement the process of object orientation in java with the help of Class-object-Constructor relationship in Object Oriented Programming
- Implement basic knowledge of code reusability with the help of Java in Object Oriented Programming.
- Analyze the significance of various keywords w.r.t Encapsulation and polymorphism technique in OOPs.Implements exception handling in Java.
- Discuss basic Data abstraction concept w.r.t. Inheritance, Package and Interface
- Implement Exception handling, Multithreading and Applet (Web program in java) programming concept in Java

CO5 K=3			S(2)		M(3)				M	M		
------------	--	--	------	--	------	--	--	--	---	---	--	--

Multimedia Technology Lab

CS(IT)594B

Contracts: 3P/Week

Credits- 2

Prerequisite:

1. Knowledge of C programming language

Course Objective(s)

- To give an overall view of multimedia tools.
- To understand and differentiate text, image, video& audio

Course Outcome(s)

- CS(IT)594B.1** To understand about various latest interactive multimedia devices, the basic concepts about images and image formats.
- CS(IT)594B.2** To understand about data compression techniques, image compression techniques like JPEG, video compression techniques like MPEG, and the basic concepts about animation.
- CS(IT)594B.3** To develop an interactive multimedia presentation by using multimedia devices and identify theoretical and practical aspects in designing multimedia applications surrounding the emergence of multimedia technology.
- CS(IT)594B.4** plan experiments to test user perception of multimedia tools
- CS(IT)594B.5** analyse the effects of scale and use on both presentation and lower level requirements

Experiments

1. Perceptual and cognitive psychology related to visual and auditory perception. **(9L)**
2. Methods of data sampling and digitization relative to different formats of audio and video media: frequency- and spatial-based sampling., vector-based and sampling-based media representations, audio and video files including AVI and WAV, uses and application of XML, media data compression. **(9L)**
3. Sound capturing & editing using tools like SOUNDFORGE **(9L)**
4. Image editing using tools like Adobe Photoshop **(9L)**
5. Creating/editing motion video/animation clips (using tools like Flash / Adobe Premier) **(9L)**

Books

1. Adobe Photoshop CC Classroom in a Book (2018 release), Pearson Ed.,
2. Anushka Wirasinha , Flash in a Flash- Web Development , PHI
3. Macromedia Flash5 fast and easy Web Development, Design, PHI

4. Lozano, Multimedia- Sound & Video , PHI

Mapping for CS594B

CO	PO1	PO2	PO3	PO4	PO5	PO6	PO7	PO8	PO9	PO10	PO11	PO12
CS(IT)594B.1	3	3	3	3	3	2	1	1	2	2	1	1
CS(IT)594B.2	3	3	3	3	3	2	1	1	2	2	2	1
CS(IT)594B.3	3	3	3	3	3	2	2	1	2	2	2	2
CS(IT)594B.4	3	3	3	3	3	3	2	1	2	1	2	3
CS(IT)594B.5	3	3	3	3	3	3	2	1	2	1	2	2
CS(IT)594B	3	3	3	3	3	2	2	1	2	2	2	2

Communication Engineering Lab

Code:CS (ECE) 594C

Contact Hours: 3P/Week

Credits: 2

Prerequisites: Knowledge in basic electronics and communication.

Course Objective(s)

- To provide the basic skills required to understand, develop, and design of various engineering applications involving analog and digital communication theory.
- To provide basic laboratory exposures for communication principles and applications.

Course Outcome(s)

CS (ECE) 594C.1 Clearly distinguish between contemporary digital communication techniques.

CS (ECE) 594C.2 Demonstrate to the practical methods of the use of generating communication signals.

CS (ECE) 594C.3 Evaluate practical methods of the use of demodulation communication signals.

CS (ECE) 594C.4 Distinguish the significance of signal constellation and spectral width.

CS (ECE) 594C.5 Develop insight into the relations between the input and output signals in various stages of a transmitter and a receiver.

CS (ECE) 594C.6 Analyze the concept of analog and digital communication techniques and their applications

Experiments

1. Measurement of modulation index of an AM signal.
2. Generation of FM using VCO chip (to view the wave shapes).
3. Study of PAM and demodulation.
4. Study of PCM and demodulation.

5. Study of ASK modulator and demodulator.
6. Study of BPSK modulator and demodulator.
7. Study of BFSK modulator and demodulator.

Text Books:

1. An Introduction to Analog and Digital Communications by Simon Haykin; Published by Wiley India.
2. Principles of Communication Systems, H. Taub and D .L.Schilling, TMH Publishing Co.

Program Outcomes (POs)												
	PO1	PO2	PO3	PO4	PO5	PO6	PO7	PO8	PO9	PO10	PO11	PO12
CS(ECE)594C .1	3	3	3		1	1			2			3
CS(ECE)594C .2	3	3		3	3		2			1	2	3
CS(ECE)594C .3	3	3	3	3	2	2			1			3
CS(ECE)594C .4	3	3	3	2	3		2			3	2	3
CS(ECE)594C .5	3	3		3	3	2						3
CS(ECE)594C .6	3	3	3			2	2	3	1	2		3

Course Objectives:

1. To generate the elementary signals/ waveforms and perform the various operation on the signals.
2. To Compute the linear convolution and verify the properties of convolution.
3. To plot frequency response of a given LTI system.
4. To Implement DFT and FFT of a given sequence.
5. To determine the z-transform of different sequences.
6. To design and Plot of Magnitude and Phase of different types of filters.

**Department of Computer Science and
Engineering**

Curriculum Structure

&

Syllabus

2016-2017

(Autonomy)

of

6th Semester

6TH SEMESTER								
SL No	Type	Code	A. THEORY	Contact hours				Cr. Points
				L	T	P	Total	
1	PC	CS601	Computer Network	3	0	0	3	3
2	PC	CS602	Microprocessor and Microcontroller	3	0	0	3	3
3	PC	CS603	Software Engineering	3	0	0	3	3
4	PE	CS604A	Compiler Design	3	0	0	3	3
		CS604B	Robotics					
		CS604C	Simulation and modeling					
5	FE	IT(CSE)605A	Pattern Recognition	3	0	0	3	3
		IT(CSE)605B	Distributed Operating System					
		IT(CSE)605C	Distributed Database					
		IT(CSE)605D	Computer Vision					
6	FE	IT(CSE)606A	Data Warehousing and Data Mining	3	0	0	3	3
		IT(CSE)606B	Digital Image Processing					
		IT(CSE)606C	E-commerce and ERP					
Total Theory							18	18
B. PRACTICAL								
7	PC	CS691	Computer Network Lab	0	0	3	3	2
8	PC	CS692	Microprocessor and Microcontroller Lab	0	0	3	3	2
9	PC	CS693	Software Engineering Lab	0	0	3	3	2
10		CS682	Mini Project	0	0	3	3	2
Total Practical							9	8
C. SESSIONAL								
10		CS681	Group Discussion and Seminar	0	0	3	3	2
Total							30	28

Syllabus

Name of the Paper: COMPUTER NETWORKS

Paper Code: CS601

Contact (Periods/Week):=3L/Week

Credit Point: 3

No. of Lectures: 36

Prerequisite:

3. Familiarity and knowledge of Operating Systems and Computer Architecture
4. Also require little bit programming languages concepts like C, Java.

Course Objective(s)

1. To educate basic knowledge of networking technologies and network management concepts
2. To interpret the layering concepts in computer networks.
3. To analyze the functions of each layer and gain knowledge in different applications that use computer networks.
4. To emphasize the hand-on experience of network topology in a laboratory environment
5. To be familiar with contemporary issues in networking technologies.

Course Outcome(s)

CS601.1: Understand OSI and TCP/IP models.

CS601.2: Analyze MAC layer protocols and LAN technologies.

CS601.3: Design applications using internet protocols.

CS601.4: Implement routing and congestion control algorithms.

CS601.5: Develop application layer protocols and understand socket programming

Module I: Introduction [6L]

Introduction (3L):

Introduction: Computer Network, data communication, topology, OSI & TCP/IP Reference Models, layers and characteristics, Wireless Network, comparison to wired and wireless network.

Physical Layer: [3L]

Overview of data (analog & digital), signal (analog & digital), transmission (analog & digital) & transmission media (guided & unguided); Circuit switching: time division & space division switch, TDM bus; Telephone Network;

Module II: Data Link Layer [10L]

Framing, Error Control, Error Detection and Correction, Flow Control, Data Link Protocols, Simple Stop-and-Wait Protocol, ARQ mechanism, Sliding Window Protocols, One-Bit Sliding Window Protocol, Go-Back-N and Selective Repeat, HDLC, PPP Medium Access Control Sub-layer, The Channel Allocation. [5L]

Multiple Access Protocols : ALOHA, Carrier Sense Multiple Access Protocols, IEEE 802.x Ethernet, Switched Ethernet, Fast Ethernet, Gigabit Ethernet, 10 Gigabit Ethernet, Wireless LANs - IEEE 802.xx , Bluetooth, RFID, Bridges, Virtual LANs, Switching.[5L]

Module III: Network Layer [10L]

IP Addressing, IPv₄ and IPv₆. Difference IPv₄ and IPv₆, Conversion of IPv₄ and IPv₆, Subnetting, Supernetting, Design Issues, Store-and-Forward Packet Switching, Virtual-Circuit and Datagram Networks, ARP, IP, ICMP, IPV6, BOOTP and DHCP–Delivery protocols Other Protocols such as mobile IP in wireless Network.. [5L]

Routing: Shortest Path Algorithms, Flooding, Distance Vector Routing, Link State Routing, Hierarchical Routing, Broadcast Routing, Multicast Routing, Anycast Routing, : RIP, OSPF, BGP; Routing for Mobile Hosts. [5L]

Transport layer: [6L]

Process to Process delivery; UDP; TCP, SCTP, TCP RENO, TCP/IP in Wireless environment, Congestion control in TCP :Congestion Control: Open Loop, Closed Loop choke packets; Quality of service: techniques to improve QoS: Leaky bucket algorithm, Token bucket algorithm. [5L]

Advanced topic such as Remote Procedure Call, Delay Tolerant Networks. [1L]

Module IV: Application Layer [4L]

Introduction to DNS, SMTP, SNMP, FTP, HTTP & WWW: Cryptography (Public, Private Key based), Digital Signature, Firewalls

Socket Programming [2L]

Introduction to Socket Programming, UDP socket and TCP Socket

Text books:

1. B. A. Forouzan – —Data Communications and Networking (3rd Ed.) — –TMH
2. S. Tanenbaum – —Computer Networks (4th Ed.)|| – Pearson Education/PHI

Recommended books:

1. Kurose and Rose – — Computer Networking -A top down approach featuring the internet – Pearson Education
2. Leon, Garica, Widjaja – —Communication Networks – TMH

Substantial/ High	3
Medium	2
Low	1
No Correlation	

CO-PO Mapping

CO	PO1	PO2	PO3	PO4	PO5	PO6	PO7	PO8	PO9	PO10	PO11	PO12
CS602.1		2		2					2			
CS602.2		2							2			
CS602.3	2	2			2				2			
CS602.4	2	2			2	2			2			
CS602.5	3	3			3				2			
CS602												

Name of the Paper: Microprocessors & Microcontrollers**Paper Code: CS602****Contact (Periods/Week): 3L/Week****Credit Point: 3****No. of Lectures: 35****Prerequisite:**

1. Familiarity with the number system
2. A solid background in digital logic.

Course Objective(s)

- To learn the basics of a particular microprocessor.
- To learn the basics of a particular microcontroller.
- To learn the interfacing of microprocessor.

Course Outcomes

CS602.1 To acquire the knowledge of hardware details of 8085 and 8086 microprocessor with the related signals and their implications

CS602.2 To develop skill in assembly Language programming of 8085

CS602.3 To understand the concept and techniques of designing and implementing interfacing of microprocessor with memory and peripheral chips involving system design

CS602.4 To acquire the knowledge of the 8051 architecture and its programming

CS602.5 To analyze the performance of computers and its architecture to real-life applications

Module -1: [9L]

Introduction to Microcomputer based system. [1L]

History of evolution of Microprocessor and Microcontrollers and their advantages and disadvantages. [1L]

Architecture of 8085 Microprocessor, Pin description of 8085. [2L] Address/data bus De-multiplexing, Status Signals and the control signals. [1L]

Interrupts of 8085 processor (software and hardware) [2L]

I/O Device Interfacing - I/O Mapped I/O and Memory Mapped I/O,

Memory interfacing with 8085 [2L]

Module -2: [11L]

Instruction set of 8085 microprocessor, Addressing modes. [3L]

Assembly language programming with examples, Counter and Time Delays, Stack and Subroutine. [6L]

Timing diagram of the instructions (a few examples) [2L]

Module 3: [8L]

The 8086 microprocessor- Architecture, Pin Details, Addressing modes, Interrupts [3L]

Instruction set, Examples of Simple Assembly Language [3L]

Memory interfacing with 8086 [2L]

Module -4: [7L]

Introduction to 8051 Microcontroller – Architecture, Pin Details. [3L]

Addressing modes, Instruction set, Examples of Simple Assembly Language. [4L]

Text Books:

1. MICROPROCESSOR architecture, programming and Application with 8085 - R. Gaonkar (Penram international Publishing LTD.) [*For Module 1 and 2*]
2. Fundamentals of Microprocessor and Microcontrollers - B. Ram (Paperback) [*For Module 3*]
3. 8051 Microcontroller – K. Ayala (Cengage learning) [*For Module 4*]

Recommended books:

1. 8086 Microprocessor – K Ayala (Cengage learning)
2. The 8051 microcontroller and Embedded systems - Mazidi, Mazidi and McKinley (PEARSON)
3. Microprocessors – The 8086/8088, 80186/80386/80486 and the Pentium family – N. B. Bahadure (PHI).

CO-PO Mapping

CO	PO1	PO2	PO3	PO4	PO5	PO6	PO7	PO8	PO9	PO10	PO11	PO12
CS602.1	3		3								2	
CS602.2			2	1								
CS602.3	1		3	2		1	1				1	
CS602.4	2		1									
CS602.5				2		2	2				2	

PaperName:SoftwareEngineering

Code:CS603

Contacts:3L

Credits:3

Allottedhours:34L

Prerequisite:

1. An understanding of basic computer software
2. Object Oriented programming skills.

Course Objective(s)

1. To develop basic Knowledge in Software Engineering and its applications.
2. To understand software Engineering layered architecture and the process frame work.
3. To analyze software process models such as the waterfall, spiral, evolutionary models and agile method for software development.
4. To design software requirements and specifications of documents.
5. To understand project planning, scheduling, cost estimation, risk management.
6. To describe data models, object models, context models and behavioral models.
7. To learn coding style and testing issues.
8. To know about the quality checking mechanism for software process and product.

Course Outcomes

- CS 603.1** To identify, formulate, and solve software engineering problems, including the specification, design, implementation, and testing of software systems that meet specification, performance, maintenance and quality requirements
- CS 603.2** To analyze, elicit and specify software requirements through a productive working relationship with various stakeholders of the project
- CS 603.3** To design applicable solutions in one or more application domains using software engineering approaches that integrates ethical, social, legal and economic concerns.
- CS 603.4** To develop the code from the design and effectively apply relevant standards and perform testing, and quality management and practice.
- CS 603.5** To identify modern engineering tools necessary for software project management, time management and software reuse, and an ability to engage in life-long learning.

ModuleI(6L)

SoftwareEngineering—Characteristics,Components,Application,Definitions,SoftwareProcessmodels-WaterfallModel,Prototypemodel,RAD,EvolutionaryModels,Incremental,Spiral.,SoftwareProjectPlanning-FeasibilityAnalysis,TechnicalFeasibility,Cost-BenefitAnalysis,Basics of estimation : COCOMO (Basic, intermediate, Complete) model

ModuleII(6L)

SystemAnalysis:PrincipleofStructureAnalysis,RequirementAnalysis,DFD,EntityRelationshipDiagram,DataDictionary,DataModeling,SoftwareRequirementsSpecification

SoftwareDesignAspects:Objectives,Principles,Concepts,HLD and LLD,Top-DownandBottom-Updesign;Decision tree,decisiontableandstructuredEnglish,Structurechart,TransformanalysisFunctional Vs.Object-Orientedapproach.

ModuleIII(3L)

Introduction to Agile Methodology ,Agile Testing , Quality in agile software development

ModuleIV(4L)

UnifiedModelingLanguage:
 Clasdiagram,interactiondiagram:collaborationdiagram,sequencediagram,statechartdiagram,activity, diagram,implementationdiagram, Use Case diagram

ModuleV(10L)

Coding&Documentation–StructuredProgramming,ModularProgramming,ModuleRelationship-Coupling,Cohesion,OOProgramming,InformationHiding,Reuse,SystemDocumentation.

Testing–LevelsofTesting,IntegrationTesting,SystemTesting.

TestCases-

WhiteBoxandBlackBoxtestingSoftwareQuality,QualityAssurance,SoftwareMaintenance,SoftwareConfigurationManagement,SoftwareArchitecture.

ModuleVI (5L)

Software Project Management – Project Scheduling, Staffing, Quality Assurance, Risk Management: Reactive vs. Proactive Risk strategies, software risks, Risk identification, Risk projection, Risk refinement Project Monitoring.

Text Book

1. SoftwareEngineering:Apractitioner’sapproach–Pressman(TMh)

ReferenceBooks

1. SoftwareEngineering-PankajJalote(Wiley-India)
2. SoftwareEngineering-RajibMall(PHI)
4. SoftwareEngineering–AgarwalandAgarwal(PHI)

CO	PO1	PO2	PO3	PO4	PO5	PO6	PO7	PO8	PO9	PO10	PO11	PO12
CS 603.1	1	1	2	2	1							
CS 603.2	2	2	1									
CS 603.3						2		1		1		
CS 603.4										2		
CS 603.5									3		1	2

CS 603.6									2	1	2	2
----------	--	--	--	--	--	--	--	--	---	---	---	---

Name of the Paper: Compiler Design

Paper Code: CS604A

Contact (Periods/Week): 3L / Week

Credit Point: 3

No. of Lectures: 35

Prerequisite:

- ✓ Mathematics
- ✓ Concept of programming languages
- ✓ Data structures
- ✓ Computer architecture
- ✓ Formal languages and automata theory
- ✓ Some advanced math might be required if you adventure in code optimization

Course Objectives:

- To make the student understand the process involved in a compiler, create an overall view of various types of translators, linkers, loaders, and phases of a compiler,
- Understand what is syntax analysis, various types of parsers especially the top down approach, awareness among students the various types of bottom up parsers,
- Understand the syntax analysis and, intermediate code generation, type checking, the role of symbol table and its organization, Code generation, machine independent code optimization and instruction scheduling.

Course Outcomes:

- CS604A .1. To illustrate the basic concept of compilers and discuss on the components as well as the strengths and weaknesses of various phases of designing a compiler.
- CS604A .2. To formulate the theories of creating simple compilers using C programming languages.
- CS604A .3. To design and analyze algorithms for syntactic and semantic analysis of the process of designing compilers.
- CS604A .4. To explain the role of finite automata in compiler design.
- CS604A .5. Identify the similarities and differences among various parsing techniques and grammar transformation techniques

Syllabus:

Module I [7L]

Compilers, Cousins of the Compiler, Analysis-synthesis model, The phases of the compiler.

CS604A.3			3									
CS604A.4	3	2										
CS604A.5				3								

PaperName:ROBOTICS

Code:CS604B

Contacts:3L

Credits:3

Allottedhours:35L

Prerequisite:

1. Microprocessor & Microcontroller
2. Computer Organization & Architecture

Course Objective

1. To study microcontroller operations for robotics.
2. To study how different interfaces are actually implemented in a microcontroller.
3. To learn how Microchip PIC micro PIC16F627 can be erased and reprogrammed
4. To learn how different sensors, outputs, and peripherals can be wired to a microcontroller to work cooperatively and create a high-level control program.
5. To design robots in a real time environment.

Course Outcome: After the successful completion of this course, the student will be able to:

- CS 604B.1 To describe and explain the microcontrollers used the in robots
- CS 604B.2. To design the software and build the prototype of robots
- CS 604B.3. To apply localization and mapping aspects of mobile robotics.
- CS 604B.4. To demonstrate self-learning capability.

Syllabus:

MODULE I (5L)

Brief history, types, classification and usage, Science and Technology of robots, Some useful websites, textbooks and research journals.

Position and orientation of a rigid body, Homogeneous transformations, Representation of joints, link representation using D-H parameters, Examples of D-H parameters and link transforms, different kinds of actuators – stepper, DC servo and brushless motors, model of a DC servo motor, Types of transmissions, Purpose of sensors, internal and external sensors, common

sensors – encoders, tachometers, strain gauge based force-torque sensors, proximity and distance measuring sensors, and vision.

MODULE II (8L)

Introduction, Direct and inverse kinematics problems, Examples of kinematics of common serial manipulators, workspace of a serial robot, Inverse kinematics of constrained and redundant robots, Tractrix based approach for fixed and free robots and multi-body systems, simulations and experiments, Solution procedures using theory of elimination, Inverse kinematics solution for the general 6R serial manipulator.

Degrees-of-freedom of parallel mechanisms and manipulators, Active and passive joints, Constraint and loop-closure equations, Direct kinematics problem, Mobility of parallel manipulators, Closed-form and numerical solution, Inverse kinematics of parallel manipulators and mechanisms, Direct kinematics of Gough-Stewart platform.

MODULE III (8L)

Linear and angular velocity of links, Velocity propagation, Manipulator Jacobians for serial and parallel manipulators, Velocity ellipse and ellipsoids, Singularity analysis for serial and parallel manipulators, Loss and gain of degree of freedom, Statics of serial and parallel manipulators, Statics and force transformation matrix of a Gough-Stewart platform, Singularity analysis and statics.

Mass and inertia of links, Lagrangian formulation for equations of motion for serial and parallel manipulators, Generation of symbolic equations of motion using a computer, Simulation (direct and inverse) of dynamic equations of motion, Examples of a planar 2R and four-bar mechanism, Recursive dynamics, Commercially available multi-body simulation software (ADAMS) and Computer algebra software Maple.

MODULE IV (9L)

Joint and Cartesian space trajectory planning and generation, Classical control concepts using the example of control of a single link, Independent joint PID control, Control of a multi-link manipulator, Non-linear model based control schemes, Simulation and experimental case studies on serial and parallel manipulators, Control of constrained manipulators, Cartesian control, Force control and hybrid position/force control, Advanced topics in non-linear control of manipulators.

Models of flexible links and joints, Kinematic modeling of multi-link flexible robots, Dynamics and control of flexible link manipulators, Numerical simulations results, Experiments with a planar two-link flexible manipulator.

CS 604B.4	2	2											3
--------------	---	---	--	--	--	--	--	--	--	--	--	--	---

Name of the Paper: Simulation and Modeling

Paper Code: CS604C

Contact (Periods/Week):=3L/Week

Credit Point: 3

No. of Lectures: 36

Prerequisite:

1. Programming and Data Structures
2. Discrete Mathematics and Probability theory
3. Game theory
4. Numerical Analysis

Course Objective(s)

1. To understand the Models and Simulation of Continuous and Discrete Systems.
2. To enable students to analyze Continuous Uniformly Distributed Random Numbers
3. To assess the strengths and weaknesses of various methods and to analyze their behavior.

Course Outcome(s)

On completion of the course students will be able to

CS604C .1. Student will be able to summarize the issues in Modelling and Simulation.

CS604C.2. Student will be able to explain the System Dynamics & Probability concepts in Simulation.

CS604C.3. Student will be able to solve the Simulation of Queuing Systems

CS604C.4. Student will be able to analyze the Simulation output.

CS604C.5. Student will be able to identify the application area of Modelling and Simulation, and apply them.

Module-I: Introduction to Modelling and Simulation 6L

Nature of Simulation. Systems , Models and Simulation, Continuous and Discrete Systems, system modelling, Components of a simulation study, Introduction to Static and Dynamic System simulation , Application areas, Advantages ,Disadvantages and pitfalls of Simulation.

Module –II : System Dynamics & Probability concepts in Simulation 10L

Exponential growth and decay models, Generalization of growth models , Discrete and Continuous probability functions, Continuous Uniformly Distributed Random Numbers, Generation of a Random numbers, Generating Discrete distributions, Non-Uniform Continuously Distributed Random Numbers, Rejection Method.

Module-III : Simulation of Queuing Systems and Discrete System Simulation 14L

Poisson arrival patterns, Exponential distribution, Service times, Normal Distribution Queuing Disciplines, Simulation of single and two server queue. Application of queuing theory in computer system. Discrete Events ,Generation of arrival patterns ,Simulation programming tasks , Gathering statistics, Measuring occupancy and Utilization , Recording Distributions and Transit times .

Module-IV : Analysis of Simulation output 5L

Sensitivity Analysis, Validation of Model Results

Text Book

1. Jerry Banks, John Carson, B.L.Nelson and D.M.Nicol — Discrete Event System Simulation, Fifth Edition, Pearson.
2. Narsingh Deo, 1979, System Simulation with Digital Computers, PHI.
3. Geoffrey Gordon, -System Simulation, PHI.

References Book

1. Averill M. Law and W.David Kelton, -Simulation Modelling and Analysis, Third Edition, McGraw Hill 5. J. N. Kapoor.. Mathematical Modelling, Wiley eastern Limited

CO-PO Mapping

CO	PO1	PO2	PO3	PO4	PO5	PO6	PO7	PO8	PO9	PO10	PO11	PO12
CS604C.1	3					1						2
CS604C.2	3	2	1									2
CS604C.3	2	3	2	2	3	2	2	2				2
CS604C.4	2	2	3	1	3	1						2
CS604C.5	1	3	1	1	3	1		2				2
CS604C	2	3	2	1	3	1	2	2				2

Paper Name: Pattern Recognition

Code: IT(CSE)605A

Contacts: 3L

Credits: 3

Allotted hours: 35L

Prerequisites:

- Probability theory,
- Artificial Intelligence

Course Objectives

- Understand the concept of a pattern and the basic approach to the development of pattern recognition and machine intelligence algorithms
- Understand the basic methods of feature extraction, feature evaluation, and data mining
- Understand and apply both supervised and unsupervised classification methods to detect and characterize patterns in real-world data
- Develop prototype pattern recognition algorithms that can be used to study algorithm behavior and performance against real-world multivariate data

Course Outcome (CO)

After the completion of four years of B.Tech., students will be able to:

IT(CSE)605A.1 Explain and compare a variety of pattern classification methods.

IT(CSE)605A.2 Analyze different clustering and classification problem and solve using different pattern recognition technique.

IT(CSE)605A.3 Apply performance evaluation methods for pattern recognition, and can do comparisons of techniques

IT(CSE)605A.4 Apply pattern recognition techniques to real-world problems such as document analysis and recognition.

IT(CSE)605A.5 Implement simple pattern classifiers, classifier combinations, and structural pattern recognizers.

Syllabus

Module - I

Introduction[2]: The nature of statistical pattern recognition, Definitions, data sets for Pattern Recognition

Different Paradigms of Pattern Recognition [1]

Representations of Patterns and Classes [1]

Different learning paradigms, The basic structure of a pattern recognition system[1]

Module - II

Feature extraction [2]:

Feature Extraction , Feature subset selection, and classification stages

Dimensionality reduction[4]: Principal component analysis , Fisher discriminant analysis , Factor Analysis

Module - III

Different Approaches to Prototype Selection [2]

Nearest Neighbour Classifier and variants [2]

Bayes Classifier [3]

Decision Trees [3]

Linear Discriminant Function [3]

Module – IV

Support Vector Machines [2]

Clustering [3]

Clustering Large datasets [2]

Combination of Classifiers [2]

Applications - Document Recognition [2]

Text Books:

- R.O.Duda, P.E.Hart and D.G.Stork, Pattern Classification, John Wiley, 2001
- Devi V.S.; Murty, M.N. (2011) Pattern Recognition: An Introduction, Universities Press, Hyderabad.

Reference books:

- S.Theodoridis and K.Koutroumbas, Pattern Recognition, 4th Ed., Academic Press, 2009
- C.M.Bishop, Pattern Recognition and Machine Learning, Springer, 2006

CO-PO Mapping

CO	PO1	PO2	PO3	PO4	PO5	PO6	PO7	PO8	PO9	PO10	PO11	PO12
CO1	3			3								2
CO2	3	3										
CO3		3				2						

CO4	2			3			3				
CO5	3			2	3		1				3

Distributed Operating System

IT(CSE)605B

Contracts: 3L

Credits- 3

Total Lecture: [33L]

Prerequisites

Concept of Operating System

Objective(s)

This course covers general issues of design and implementation of distributed operating systems. The focus is on issues that are critical to the applications of distributed systems and computer networks, which include inter-process communication, distributed processing, sharing and replication of data and files.

Outcome(s)

On successful completion of the learning sessions of the course, the learner will be able to:

IT(CSE)605B.1 Define the distributed operating system, architecture, goal of DOS and its designing issues.

IT(CSE)605B.2 Explain the technique of inter-process communication.

IT(CSE)605B.3 Analyze the need of local clock instead of global clock and the different mutual exclusion and deadlock algorithms.

IT(CSE)605B.4 Explain the distributed file system and shared memory architecture.

IT(CSE)605B.5 Develop the idea about the designing policy of different distributed operating system like AMOEBA, MACH, DCE

Module 1:

Fundamentals of Distributed System [5]

Definition of distributed system, Examples of distributed system, Types of distributed system, Distributed Operating System, Issues in designing a distributed operation system.

System Architecture: Centralized architecture, decentralized architecture and hybrid architecture.

Communication [4]

Inter-process communication-Message Passing: features, issues, synchronization, mult Datagram message,

Remote Procedure Call, RPC message, Marshaling arguments and results, Server management.

Module 2:

Clock Synchronization: [2]

CO1	3	2	2	2								
CO2	3	3	2	3	2					2		
CO3	3		3	3								
CO4	3	3	2		2							
CO5	3	3	3		3					2		

Name of the Paper: Distributed Database

Paper Code: IT(CSE)605C

Contact (Periods/Week):=3L/Week

Credit Point: 3

No. of Lectures: 41

Prerequisite:

3. Good knowledge in Database Management System.
4. Determination to learn new and difficult things.

Course Objective(s)

- To learn the principal and foundation of distributed database.
- To learn the architecture, design issue and integrity control of distributed database.
- To learn the details of query processing and query optimization technique.
- To learn the concept of transaction management in distributed database.

Course Outcome(s)

On completion of the course students will be able to

IT(CSE)605C.1: Describe database management system internals, understand and describe internal algorithms in detail.

IT(CSE)605C.2: Identify and be able to use recent and advanced database techniques (e.g. in concurrency control, buffer management, and recovery

IT(CSE)605C.3: Decide on configuration issues related to database operation and performance. Identify which parameters are suitable and what are its implications

IT(CSE)605C.4: Analyze and optimize transactional code, identifying causes of possible anomalies and correct them.

IT(CSE)605C.5: Decide on optimization issues given a known database workload, by manipulating indexes, choosing more adequate data types, and modifying queries.

Syllabus

Module I: [9L]

Introductory concepts and design of (DDBMS)

Data Fragmentation; Replication; and allocation techniques for DDBMS; Methods for designing and implementing DDBMS, designing a distributed relational database; Architectures for DDBMS: cluster federated, parallel databases and client server architecture.

Module II:[9L]**Query Processing[4L]**

Overview of Query Processing: Query processing problem; Objectives of Query Processing; Complexity of Relational Algebra operations; characterization of Query processors; Layers of Query Processing; Translation of global queries.

Transaction**Management[5L]**

Introduction To Transaction Management: Definition of Transaction, Properties of Transaction, types of transaction ; Distributed Concurrency Control: Serializability theory; Taxonomy of concurrency control mechanisms; locking bases concurrency control algorithms.

Module III:[5L]

Partitioned network; check point and cold start; Management of distributed transaction; Architectural aspect; Node and link failure recoveries

Module IV:[6L]

Distributed data dictionary management. Distributed database administration. Heterogeneous databases-federateddatabase, reference architecture, loosely and tightly coupled.

Module V:[6L]**Distributed Object Database Management systems [6L]**

Fundamental Object concepts and Object models; Object distribution design; Architectural issues; Object management; Distributed object storage; Object query processing

Module IV:[6L]**Current trends & developments related to Distributed database applications technologies [6L]**

Distributed Object/component-based DBMS; Database Interoperability including CORBA; DCOM and Java RMI;Distributed document-based systems; XML and Workflow management.

Text books:

1. Distributed Databases - Principles and Systems; Stefano Ceri; Guiseppe Pelagatti; Tata McGraw Hill; 1985.
2. Fundamental of Database Systems; Elmasri & Navathe; Pearson Education; Asia

Reference books:

1. Database System Concepts; Korth & Sudarshan; TMH
2. Principles of Distributed Database Systems; M. Tamer Özsu; and Patrick Valduriez Prentice Hall

CO-PO Mapping

CO#	P O 1	PO 2	PO 3	PO 4	PO 5	PO 6	PO 7	PO 8	PO 9	PO10	PO11	PO1 2	PSO 1	PSO 2	PSO 3
IT(CSE)605C.1		2	2	3	1				2	2	3	2	3	2	2
IT(CSE)605C.2	1	2	3	2							2	2	2	2	2
IT(CSE)605C.3	2	3	2	2	1							1	2	1	2

IT(CSE)605C.4	2	3	2	2	2							1	2	2	2
IT(CSE)605C.5	2	3	2	2	2						2	2	2	2	1
IT(CSE)605C	2	3	2	2	2	-	-	-	2	2	2	2	2	2	2

Computer Vision

IT(CSE)605(D)

Contact: 3L

Credits: 3

Total Lectures: 36L

Course Objective:

Computer Vision focuses on development of algorithms and techniques to analyze and interpret the visible world around us. This requires understanding of the fundamental concepts related to multi-dimensional signal processing, feature extraction, pattern analysis visual geometric modeling, stochastic optimization etc. Knowledge of these concepts is necessary in this field, to explore and contribute to research and further developments in the field of computer vision. Applications range from Biometrics, Medical diagnosis, document processing, mining of visual content, to surveillance, advanced rendering etc.

Course Outcome:

On completion of the course students will be able to

IT(CSE)605D.1	Understand fundamental image processing techniques required for computer vision
IT(CSE)605D.2	Understand 3D vision techniques
IT(CSE)605D.3	Implement boundary tracking techniques
IT(CSE)605D.4	Apply chain codes and other region descriptors to perform shape analysis
IT(CSE)605D.5	Apply Hough Transform for line, circle, and ellipse detections and develop applications using computer vision techniques

Introduction [2L]

Impact of Computer Vision, Components and Its Applications.

Digital Image Formation and low-level processing [5L]

Overview and State-of-the-art, Fundamentals of Image Formation, Transformation: Orthogonal, Euclidean, Affine, Projective, etc; Fourier Transform, Convolution and Filtering, Image Enhancement, Restoration, Histogram Processing.

Depth estimation and Multi-camera views (5L)

Perspective, Binocular Stereopsis: Camera and Epipolar Geometry; Homography, Rectification, DLT, RANSAC, 3-D reconstruction framework; Auto-calibration. apparel

Feature Extraction [7L]

Edges - Canny, LOG, DOG; Line detectors (Hough Transform), Corners - Harris and Hessian Affine, Orientation Histogram, SIFT, SURF, HOG, GLOH, Scale-Space Analysis- Image Pyramids and Gaussian derivative filters, Gabor Filters and DWT.

Image Segmentation(4L)

Region Growing, Edge Based approaches to segmentation, Graph-Cut, Mean-Shift, MRFs, Texture Segmentation; Object detection.

Pattern Analysis (7L)

Clustering: K-Means, K-Medoids, Mixture of Gaussians, Classification: Discriminant Function, Supervised, Un-supervised, Semi-supervised; Classifiers: Bayes, KNN, ANN models; Dimensionality Reduction: PCA, LDA, ICA; Non-parametric methods.

Motion Analysis (3L)

Background Subtraction and Modeling, Optical Flow, KLT, Spatio-Temporal Analysis, Dynamic Stereo; Motion parameter estimation.

Shape from X (3L)

Light at Surfaces; Phong Model; Reflectance Map; Albedo estimation; Photometric Stereo; Use of Surface Smoothness Constraint; Shape from Texture, color, motion and edges.

Books:**Textbooks:**

Richard Szeliski, Computer Vision: Algorithms and Applications, Springer-Verlag London Limited 2011.
Computer Vision: A Modern Approach, D. A. Forsyth, J. Ponce, Pearson Education, 2003.

References:

Richard Hartley and Andrew Zisserman, Multiple View Geometry in Computer Vision, Second Edition, Cambridge University Press, March 2004.

K. Fukunaga; Introduction to Statistical Pattern Recognition, Second Edition, Academic Press, Morgan Kaufmann, 1990.

R.C. Gonzalez and R.E. Woods, Digital Image Processing, Addison- Wesley, 1992.

Journals:

IEEE-T-PAMI (IEEE Transactions on Pattern Analysis and Machine Intelligence).

IJCV (International Journal of Computer Vision) - Springer.

CO and PO Mapping Where 1 = Low, 2 = Medium, 3 = High.

CO	PO1	PO2	PO3	PO4	PO5	PO6	PO7	PO8	PO9	PO10	PO11	PO12
IT(CSE)605D. 1	3	3	1	1	2	3	-	-	-	-	1	3
IT(CSE)605D. 2	1	1	1	1	1	-	-	-	-	-	1	3
IT(CSE)605D.	3	1	2	3	3	-	2	-	2	-	-	2

3												
IT(CSE)605D. 4	3	1	2	3	3	3	2	-	2	-	-	2
IT(CSE)605D. 5	3	1	3	3	3	3	2	-	2	-	-	2

Name of the Paper: Data Warehousing & Data Mining

Paper Code: IT(CSE)606A

Contact (Periods/Week): = 3L/Week

Credit Point: 3

No. of Lectures: 36

Prerequisite:

- 5. Programming and Data Structures
- 6. Database Systems

Course Objective(s)

- 1. To understand classical models and algorithms in data warehousing and data mining.
- 2. To enable students to analyze the data, identify the problems, and choose the relevant models and algorithms to apply.
- 3. To assess the strengths and weaknesses of various methods and algorithms and to analyze their behavior.

Course Outcome(s)

On completion of the course students will be able to

- IT(CSE)606A .1. Student will be able to summarize the issues in Data mining.
- IT(CSE)606A.2. Student will be able to explain and give examples of Data warehousing.
- IT(CSE)606A.3. Student will be able to solve Business problems and can apply the Data mining in real applications in industry.
- IT(CSE)606A.4. Student will also be able to implement the classical algorithms in data mining and data warehousing.
- IT(CSE)606A.5. identify the application area of algorithms, and apply them

Module I: Introduction to Data Warehousing 08L

Data Warehousing: Data warehouse Architecture and Infrastructure , Data warehousing Components –Building a Data warehouse – Mapping the Data Warehouse to a Multiprocessor Architecture – DBMS Schemas for Decision Support –Data Extraction, Cleanup, and Transformation Tools –Metadata.

Module II: Business Analysis05 L

Business Analysis: Reporting and Query tools and Applications – Tool Categories – The Need for Applications – Cognos Impromptu – Online Analytical Processing (OLAP) – Need – Multidimensional Data Model – OLAP Guidelines – Multidimensional versus Multirelational OLAP – Categories of Tools – OLAP Tools and the Internet.

Module III: Data Mining and Classification12L

Data Mining: Introduction – Data – Types of Data – Data Mining Functionalities – Interestingness of Patterns – Classification of Data Mining Systems – Data Mining Task Primitives –Integration of a Data Mining System with a Data Warehouse – Issues –Data Preprocessing.

Association Rule Mining and Classification: Mining Frequent Patterns, Associations and Correlations – Mining Methods – Mining Various Kinds of Association Rules – Correlation Analysis – Constraint Based Association Mining – Classification and Prediction - Basic Concepts - Decision Tree Induction – Bayesian Classification – Rule Based Classification – Classification by Backpropagation – Support Vector Machines – Associative Classification – Lazy Learners – Other Classification Methods – Prediction.

Module IV: Clustering and Applications 11L

Clustering and Applications and Trends in Data Mining: Cluster Analysis - Types of Data – Categorization of Major Clustering Methods – Kmeans – Partitioning Methods – Hierarchical Methods - Density-Based Methods –Grid Based Methods – Model-Based Clustering Methods – Clustering High Dimensional Data - Constraint – Based Cluster Analysis – Outlier Analysis – Data Mining Applications.

Text Books

1. Jiawei Han and Micheline Kamber, -Data Mining Concepts and TechniquesI, SecondEdition, Elsevier, 2007.
2. Pang-Ning Tan, Michael Steinbach and Vipin Kumar, — Introduction To Data MiningII,Person Education, 2007.

Reference Book

1. Daniel T.Larose, -Data Mining Methods and ModelsI, Wile-Interscience, 2006.
2. Margaret H. Dunham, "Data Mining: Introductory and Advanced Topics", Prentice Hall, 2003.

CO-PO Mapping

CO	PO1	PO2	POP3	PO4	PO5	PO6	PO7	PO8	PO9	PO10	PO11	PO12
----	-----	-----	------	-----	-----	-----	-----	-----	-----	------	------	------

IT(CSE)606A.1	3					1						2
IT(CSE)606A.2	3	2	1									3
IT(CSE)606A.3	2	3	2	2		2	2	2				3
IT(CSE)606A.4	2	2	3	1	1	1						2
IT(CSE)606A.5	1	3	1	1		1		2				3
IT(CSE)606A	2	3	2	1	1	1	2	2				3

Name of the Paper: Digital Image Processing

Paper Code: IT(CSE)606B

Contact (Periods/Week): 3L/Week

Credit Point: 3

No. of Lectures: 35

Prerequisite:

- Fourier analysis

Course Objective(s)

- To learn discrete Fourier transform and its properties
- To study the monochrome and color image fundamentals
- To learn the analytical tools and methods which are currently used in digital image processing as applied to image information for human viewing.
- To learn image compression and segmentation techniques.

Course Outcomes

IT(CSE)606B.1 To acquire the knowledge of basic preprocessing techniques in monochrome and color images.

IT(CSE)606B.2 To develop skill in concepts of image enhancement like linear and non linear spatial filters using MATLAB.

IT(CSE)606B.3 To understand the concept and techniques of simple image processing projects using different methods of restoration.

IT(CSE)606B.4 To acquire the knowledge of the various segmentation algorithms for practical applications.

IT(CSE)606B.5 To analyze the performance of Lossless and Lossy compression techniques in images.

Module -1: Introduction:[5L]

Digital Image Fundamentals : Overview, Computer imaging systems , Digital Image Representation, Fundamental steps in Image Processing [1L], Elements of Digital Image Processing - Image Acquisition, Storage, Processing, Communication, Display [1L]. Digital Image Formation: A Simple Image Model, Use and Analysis of Color Models in Image Processing [2L], Sampling & Quantization - Uniform & Non-uniform [1L].

Module -2: Mathematical Preliminaries : [5L]

Neighbour of pixels, Connectivity, Relations, Equivalence & Transitive Closure [1L]; Distance Measures, Arithmetic/Logic Operations, Discrete Signals and Systems [1L]- A Review – Fourier Transformation, Properties of The Two Dimensional Fourier Transform [2L], Discrete Fourier Transform, Discrete Cosine & Sine Transform [1L].

Module 3: Image Enhancement : [6L]

Spatial Domain: Gray level transformations – Histogram processing [2L] Basics of Spatial Filtering–Smoothing and Sharpening Spatial Filtering – Frequency Domain [2L]– Smoothing and Sharpening frequency domain filters – Ideal, Butterworth and Gaussian filters [2L].

Module -4: Image Restoration, Segmentation and Filtering :[14L]

Image Restoration and Segmentation:Image restoration: noise removal: mean & adaptive filters, degradation model, inverse filter [2L]. Discrete Formulation, Algebraic Approach to Restoration - Unconstrained & Constrained [1L]; Constrained Least Square Restoration, Restoration by Homomorphic Filtering [1L], Geometric Transformation - Spatial Transformation, Gray Level Interpolation [1L]. Image Segmentation : Point Detection, Line Detection, Edge detection, Combined detection [2L],

Module -5: Edge Linking, Boundary Detection and Image compression : [5L]

Edge Linking & Boundary Detection- Local Processing, Global Processing via The Hough Transform [2L]; Thresholding - Foundation, Simple Global Thresholding, Optimal Thresholding [2L]; Region Oriented Segmentation - Basic Formulation, Region Growing by Pixel Aggregation, Region Splitting & Merging [2L].

Image compression: system model, lossless methods , lossy methods [2L]

Module -6: Image Representation and Recognition :[5L]

Image Representation and Recognition :Boundary representation – Chain Code – Polygonal approximation [1L], signature, boundary segments – Boundary description [1L] – Shape number – Fourier Descriptor [1L], moments- Regional Descriptors –Topological feature [1L], Texture – Patterns and Pattern classes – Recognition based on matching [1L].

Text Books:

1. Chanda & Majumder , Digital Image Processing & Analysis, PHI

Reference books:

1.Malay K. Pakhira, Digital Image Processing and Pattern Recognition, First Edition, PHI Learning Pvt. Ltd., 2011.

2. Rafael C. Gonzales and Richard E. Woods, Digital Image Processing, Third Edition, Pearson Education, 2010.

CO-PO Mapping

CO	PO1	PO2	PO3	PO4	PO5	PO6	PO7	PO8	PO9	PO10	PO11	PO12
IT(CSE)606B.1	3					1	1					
IT(CSE)606B.2		1	2	1								1
IT(CSE)606B.3	1	2		2	2				1			
IT(CSE)606B.4	2					2	2			1	1	
IT(CSE)606B.5		3		1		3		1				

Name of the Paper: E Commerce & ERP

Paper Code: IT(CSE)606C

Contact (Periods/Week):=3L/Week

Credit Point: 3

No. of Lectures: 39

Prerequisite: Knowledge of Software Engineering and Networking

Course Objective(s)

- To impart knowledge on E-Commerce & ERP and its various applications.
- To understand E-Commerce framework and business model applications of E-Commerce
- To understand e-payment mechanisms

Course Outcome(s)

On completion of the course students will be able to

IT(CSE)606C.1 **Define** and **differentiate** various types of Ecommerce.

IT(CSE)606C.2 **Define** and **describe** E-business and its Models.

IT(CSE)606C.3 **Describe** Hardware and Software Technologies for Ecommerce.

IT(CSE)606C.4 **Understand** the basic concepts of ERP and **identify** different technologies used in ERP.

IT(CSE)606C.5 **Apply** different tools used in ERP

Module 1: Overview of E-Commerce[10L]

Introduction to E-Commerce [4L]: Definition, Scope of E-Commerce, Hardware requirements, E-Commerce and Trade Cycle, Electronic Markets, Electronic Data Interchange and Internet Commerce.

Business to Business E-Commerce [6L]: Electronic Markets, Electronic Data Interchange (EDI): Technology, Standards (UN/EDIFACT), Communications, Implementations, Agreements, Security, EDI and Business, Inter-Organizational E-commerce.

Module 2: Security Issues in E-Commerce [10L]

Legal issues [4L]: Risks: Paper Document vs. Electronic document, Authentication of Electronic document, Laws, Legal issues for Internet Commerce: Trademarks and Domain names, Copyright, Jurisdiction issues, Service provider liability, Enforceable online contract.

Security Issues [6L]: Security Solutions: Symmetric and Asymmetric Cryptosystems, RSA, DES, and Digital Signature, Protocols for secure messaging, Secure Electronic Transaction (SET) Protocol, Electronic cash over internet, Internet Security.

Module 3: Applications [3L]

E-business [3L]: Internet bookshops, Software supplies and support, Electronic Newspapers, Internet Banking, Virtual Auctions, Online Share Dealing, Gambling on the net, E-Diversity, Case studies through internet.

Module 4: Overview of ERP (9L)

The evolution of ERP systems: A historical perspective [4L]

Evolution through Payroll system, Inventory Control system, Materials Requirement Planning (MRP I) system, Manufacturing Resource Planning (MRP II) system, their advantages and disadvantages. Definition and Concept of ERP, Business reasons for rise and popularity of ERP system - Benefits of an ERP system

Business processes supported by ERP systems [5L]

Various business functions in an Organization – Purchasing, Materials Management, Manufacturing, Sales & Distribution, Plant Maintenance, Quality Management, Finance & Accounting including Costing, Human Resources etc.

ERP market place – SAP, Oracle, PeopleSoft, JD Edwards, Baan, Microsoft's suit of products etc. Business modules in these ERP packages – a brief comparative description of business function modules and sub-modules.

Overview of key end-to-end business processes supported in two major ERP systems (preferably SAP and Oracle) – Order to Cash, Procure to Pay, Plan to Produce and Despatch.

Module 5 : Emerging Trends and Future of ERP systems (7L)

Emerging Technologies and ERP [5L]

Service-oriented Architecture (SOA): Enterprise SOA layers – Business processes, Business services, Components and Integration services, Advantages and Drawbacks of SOA, When to use SOA, Difference between multi-layered Client-server architecture and SOA, basic awareness of NetWeaver from SAP, Websphere from Oracle and .Net from Microsoft. Enterprise Application Integration (EAI): Basic understanding of the concept, Types of EAI (levels) – User Interface, Method (logic), Application Interface, Data. EAI architecture – Typical framework (Business Processes, Components & Services, Messaging service, and Transport service. Mention

of some of the leading EAI vendors – IBM, Microsoft, Oracle, SAP, TIBCO. Radio Frequency Identification (RFID) and ERP: awareness of RFID technology, Benefits of RFID integrated with ERPs. M-Commerce: basic concept and applications, difference with E-Commerce, benefits of integration with ERPs.

Future of ERP Technology[2L]

Transformation to SOA, more E-Commerce features, Growing mobile applications, Economical and Easy models of ERP deployment etc.

Text books:

1. E-Commerce-Strategy, Technologies & Applications by David Whitley, TMH
2. Enterprise Resource Planning – A Managerial Perspective by D P Goyal, Tata McGraw Hill Education

Recommended books:

1. E-Commerce- The cutting edge of business by Kamlesh K. Bajaj, TMH
2. Global Electronic Commerce- Theory and Case Studies by J. Christopher Westland and Theodore H. K Clark, University Press
3. Enterprise Resource Planning by Ashim Raj Singla, Cengage Learning

CO-PO Mapping

CO	PO1	PO2	PO3	PO4	PO5	PO6	PO7	PO8	PO9	PO10	PO11	PO12
IT(CSE)606C.1	2	2	3	1			1		3	3	3	1
IT(CSE)606C.2	2	2	3	3	2	2			3	3	1	3
IT(CSE)606C.3	3	3	2	2	2	1	1		3	3	1	3
IT(CSE)606C.4	3	2	2	2	2	3			3	3	2	1
IT(CSE)606C.5	3	2	1	3	2	3			3	3	3	3
IT(CSE)606C	3	2	2	2	2	2	1	-	3	3	2	3

Practical

Name of the Paper: COMPUTER NETWORKS Lab

Paper Code: CS691

Contact (Periods/Week):=3L/Week

Credit Point: 2

No. of Lectures: 36

Prerequisite:

5. Familiarity and knowledge of Computer Network and Computer Architecture
6. Also require strong knowledge of programming languages like C, Java and UNIX or Linux environment.

Course Objectives:

1. To provide students with an overview of the concepts and fundamentals of data communication and computer networks
2. To familiarize with the basic taxonomy and terminology of computer networking area. 3
3. To experience the designing and managing of communication protocols while getting a good exposure to the TCP/IP protocol suite

Course Outcome(s)

CO1: Demonstrate the socket program using TCP & UDP.

CO2: Develop simple applications using TCP & UDP.

CO3:Develop the code for Data link layer protocol simulation.

CO4:Examine the performances of Routing protocol.

CO5:Experiment with congestion control algorithm using network simulator

Syllabus

- Familiarization of UNIX or Linux environment, UNIX or Linux general Commands specially Network Commands. Familiarization of Internetworking - Network Cables - Color coding - Crimping. Internetworking Operating Systems - Configurations. [6L]
- Implementation of flow control mechanisms [3L]
- Socket Programming using TCP and UDP [15L]

- Implementing routing protocols such as RIP, OSPF. [2L]
- Familiarization of advanced simulators like Packet Tracer, NS2/NS3, OMNET++, TinyOS [4L]
- Server Configuration: only web server (If time permit..instructor can do more than that) [6L]

Text books:

1. TCP sockets in C programs-Practical guide for Programmers By Micheal J Donahoo and Kenneth L calvert.
2. Socket Programming by rajkumar Buyaa.

Substantial/ High	3
Medium	2
Low	1
No Correlation	

CO-PO Mapping

CO	PO1	PO2	POP3	PO4	PO5	PO6	PO7	PO8	PO9	PO10	PO11	PO12
CS692.1	3	3	3	2	3	2	1		3	2	2	3
CS692.2	3	3	3	2	3	3	2	3	3	2	2	3
CS692.3	3	3	3	2	2	1	2	1	3	2	2	3
CS692.4	3	3	3	1	2	2	1	3	3	2	2	3
CS692.5	3	3	3	2	2	2	1	2	3	2	2	3
CS692	3	3	3	2	3	2	1	1	3	2	2	3

Name of the Paper: Microprocessors & Microcontrollers Lab

Paper Code: CS692

Contact (Periods/Week): 3P/Week

Credit Point: 2

No. of Lectures: 30

Prerequisite:

7. Familiarity with the number system
8. A solid background in digital logic and implementation of digital circuit in a bread board.

Course Objective(s)

- To learn the assembly language programming of a microprocessor.
- To learn the assembly language programming of a microcontroller.
- To learn the interfacing of microprocessor.
- To be familiar with microprocessor and microcontroller based projects.

Course Outcomes

CS692.1 To understand and apply the fundamentals of assembly level programming of microprocessors and microcontroller

CS692.2 To work with standard microprocessor real time interfaces including GPIO, serial ports, digital-to-analog converters and analog-to-digital converters.

CS692.3 To troubleshoot interactions between software and hardware

CS692.4 To analyze abstract problems and apply a combination of hardware and software to address the problem

CS692.5 To use standard test and measurement equipment to evaluate digital interfaces

List of Experiments:

1. Write an assembly language program to transfer a data from one memory location to another memory location.
2. Write an assembly language program to add two numbers stored in memory locations 9140 and 9141. Store the sum at 9142 and carry at 9143.
3. Write an assembly language program to add a series of numbers. The length is given in the location 913F and the series itself starts from 9140. Store the result at 9160.
4. Write an assembly language program to find maximum of a series of numbers. The length is given in the location 913F and the series itself starts from 9140. Store the result at 9160.
5. Write an assembly language program to copy 16 data from 9140-914F to 9148-9157 (overlapping memory locations).
6. A set of eight data bytes is stored in the memory location starting at 9140. Check each data byte for bits D7 and D0. If D7 or D0 is 1, reject the data byte; otherwise, store the data bytes at memory locations starting at 9160.
7. Write an assembly language program to count number of 0's and number of 1's in the string (data byte) stored in the memory location 9140. Store the results in 9141 and 9142, respectively.
8. Write an assembly language program to find HCF of two numbers stored in memory locations 9140 and 9141. Store the result at 9142.
9. Write an assembly language program to convert a BCD number to its equivalent Binary form. The BCD number is within memory location 9140. Store the bits of equivalent binary number from 9141-9148. The LSB should be stored into 9141.
10. Write an assembly language program to find square value of a number using Look Up Table.
11. Write an assembly language program to add two numbers using subroutine.
12. Write an assembly language program to fill flag register by 5D.

Text Books:

1. MICROPROCESSOR architecture, programming and Application with 8085 - R. Gaonkar (Penram international Publishing LTD.)

Recommended books:

1. Fundamentals of Microprocessor and Microcontrollers - B. Ram (Paperback)
2. The 8051 microcontroller and Embedded systems - Mazidi, Mazidi and McKinley (PEARSON)

CO-PO Mapping

CO	PO1	PO2	PO3	PO4	PO5	PO6	PO7	PO8	PO9	PO10	PO11	PO12
CS692.1	2	2	2									
CS692.2		2	3	1							1	
CS692.3		1	2	1								
CS692.4		3	2	2							1	
CS692.5			1		1							

Name of the Paper: Software Engineering Lab

Paper Code: CS693

Contact (Periods/Week): 3L

Credit Point: 2

Prerequisite:

For Software Engineering Lab, design a project proposal which will be used throughout the lab for performing different experiments using CASE Tools.

Course Objective(s)

- To learn software development skill through various stages of software life cycle. .
- To ensure the quality of software through software development with various protocol based environment.

Course Outcomes

CS693.1 To handle software development models through rational method.

CS693.2 To prepare SRS document, design document, test cases and software configuration management and risk management related document.

CS693.3 To Develop function oriented and object oriented software design using tools like rational rose.

CS693.4 To perform unit testing and integration testing

CS 693.5 To apply various white box and black box testing techniques

Assignments to be given from the following

Department of Computer Science and
Engineering

Curriculum Structure

&

Syllabus

2016-2017

of

7th Semester

7TH SEMESTER								
<u>SL No</u>	<u>Type</u>	<u>Code</u>	<u>A. THEORY</u>	L	T	P	Total	
1	PC	CS701	Artificial Intelligence	3	0	0	3	3
2	HS	HU702	Values & Ethics in Profession	2	0	0	2	2
3	PE	CS702A	Soft Computing	3	0	0	3	3
		CS702B	Natural Language Processing					
		CS702C	Web technology					
4	PE	CS703A	Cloud Computing	3	0	0	3	3
		CS703B	Data Analytics					
		CS703C	Sensor Network and IOT					
5	PE	CS704A	Distributed Algorithms	3	0	0	3	3
		CS704B	Bio-informatics					
		CS704C	Cryptography and Network Security					
Total Theory							14	14
<u>B. PRACTICAL</u>								
6	PC	CS791	Artificial Intelligence Lab	0	0	3	3	2
7	PE	CS792A	Soft Computing Lab	0	0	3	3	2
		CS792B	Natural Language Processing Lab					
		CS792C	Web Technology Lab					
8		CS795	Project-1	0	0	3	3	2
Total Practical							9	6
<u>C. SESSIONAL</u>								
9		CS781	Industrial Training	0	0	0	0	2
Total Sessional								
<u>D. MANDATORY COURSES</u>								
10	MC	MC781	Technical Skill Development	0	0	3	3	2Unit

Total					26	22
--------------	--	--	--	--	----	----

Syllabus

Theory

Name of the Paper: Artificial Intelligence

Paper Code: CS701

Contact (Periods/Week):=3L/Week

Credit Point: 3

No. of Lectures: 37

Prerequisite:

- 9. Basics of Design and Analysis of Algorithm
- 10. A solid background in mathematics, including probability.

Course Objective(s)

- To learn the overview of artificial intelligence principles and approaches.
- To develop a basic understanding of the building blocks of AI as presented in terms of intelligent agents.
- This course also covers fundamental areas of Local Search Algorithms, Adversarial Searching and Neural Networks.

Course Outcome(s)

On completion of the course students will be able to

CS701.1 Understand the concepts of Artificial intelligence

CS701.2 Analyze the dimensions along which agents and environments vary, along with key functions that must be implemented in a general agent

CS701.3 Develop intelligent algorithms for constraint satisfaction problems and also design intelligent systems for Game Playing

CS701.4 Represent knowledge of the world using logic and **infer** new facts from that Knowledge.

CS701.5 Demonstrate working knowledge in PROLOG in order to write simple PROLOG programs and **explore** more sophisticated PROLOG code on their own.

Module 1: Basics of AI [7L]

Introduction [2]

Overview of Artificial intelligence- Problems of AI, AI technique, Tic - Tac - Toe problem.

Intelligent Agents [2]

Agents & environment, nature of environment, structure of agents, goal based agents, utility based agents, learning agents.

Learning [3]

Forms of learning, inductive learning, learning decision trees, explanation based learning, learning using relevance information, neural net learning & genetic learning.

Module 2: Different types of searching algorithms [14L]

Problem Solving [3]

Problems, Problem Space & search: Defining the problem as state space search, production system, constraint satisfaction problems, issues in the design of search programs.

Search techniques [4]

Solving problems by searching: Problem solving agents, searching for solutions; uniform search strategies: breadth first search, depth first search, depth limited search, bidirectional search, comparing uniform search strategies.

Heuristic search strategies [4]

Greedy best-first search, A* search, memory bounded heuristic search: local search algorithms & optimization problems: Hill climbing search, simulated annealing search, local beam search, genetic algorithms; constraint satisfaction problems, local search for constraint satisfaction problems.

Adversarial search [3]

Games, optimal decisions & strategies in games, the minimax search procedure, alpha-beta pruning, additional refinements, iterative deepening.

Module 3: Knowledge & Reasoning [12L]

Knowledge & Reasoning [3]

Knowledge representation issues, representation & mapping, approaches to knowledge representation, issues in knowledge representation.

Using predicate logic [4]

Representing simple fact in logic, representing instant & ISA relationship, computable functions & predicates, resolution, natural deduction.

Representing knowledge using rules [2]

Procedural verses declarative knowledge, logic programming, forward verses backward reasoning, matching, control knowledge.

Probabilistic reasoning [3]

Representing knowledge in an uncertain domain, the semantics of Bayesian networks, Dempster-Shafer theory, Fuzzy sets, and fuzzy logics.

Module 4: Different fields of AI [4L]

Natural Language Processing [2]

Introduction, Syntactic processing, semantic analysis, discourse, and pragmatic processing.

Expert Systems [2]

Representing and using domain knowledge, expert system shells, and knowledge acquisition. Basic knowledge of programming language like Prolog

Text books:

1. Artificial Intelligence, Ritch & Knight, TMH
2. Artificial Intelligence, A Modern Approach, Stuart Russel, Peter Norvig ,Pearson

Recommended books:

3. Introduction to Artificial Intelligence & Expert Systems, Patterson, PHI
4. Poole, Computational Intelligence, OUP
5. Logic & Prolog Programming, Saroj Kaushik, New Age International
6. Expert Systems, Giarranto, VIKAS

CO-PO Mapping

CO	PO1	PO2	PO3	PO4	PO5	PO6	PO7	PO8	PO9	PO10	PO11	PO12
CS701.1	3	3	3	3	2	2	2	2	1	2	3	2
CS701.2	3	3	3	3	2	2	2	2	1	2	3	2
CS701.3	3	3	3	3	2	2	2	2	1	2	3	2
CS701.4	3	3	3	3	2	2	2	2	1	2	3	2
CS701.5	3	3	3	3	2	1	1	1	1	2	3	2
CS701	3	3	3	3	2	2	2	2	1	2	3	2

Paper Name: Values and Ethics in Profession

Paper Code: HU702

Contact: L-T-P= 2-0-0

Credit: 2

Pre requisites: Basic knowledge of management, basics of communication, Knowledge about environment science

Course Objective: To create awareness on professional ethics and Human Values

Course Outcome: On Completion of this course student will be able to

CO.1	Understand the core values that shape the ethical behavior of an engineer and Exposed awareness on professional ethics and human values.
CO.2	Understand the basic perception of profession, professional ethics, various moral issues & uses of ethical theories
CO.3	Understand various social issues, industrial standards, code of ethics and role of professional ethics in engineering field
CO.4	Aware of responsibilities of an engineer for safety and risk benefit analysis, professional rights and responsibilities of an engineer.
CO.5	Acquire knowledge about various roles of engineers in variety of global issues and able to apply ethical principles to resolve situations that arise in their professional lives

Course contents:

Module: 1. Introduction: Definition of Ethics; Approaches to Ethics: Psychological, Philosophical, Social.

Module: 2. Psycho-social theories of moral development: View of Kohlberg;

Morality and Ideology, Culture and Morality, Morality in everyday Context.

Module: 3. Ethical Concerns: Work Ethics and Work Values, Business Ethics, Human values in organizations: Values Crisis in contemporary society
Nature of values: Value Spectrum of a good life.

Module: 4. Ethics of Profession:

Engineering profession: Ethical issues in Engineering practice, Conflicts between business demands and professional ideals.

Social and ethical responsibilities of Technologists. Codes of professional ethics. Whistle blowing and beyond, Case studies.

Module: 5. Self Development: Character strengths and virtues, Emotional Intelligence, Social intelligence, Positive cognitive states and processes (Self-efficacy, Empathy, Gratitude, Compassion, and Forgiveness).

Module: 6. Effects of Technological Growth:

Rapid Technological growth and depletion of resources, Reports of the Club of Rome. Limits of growth: sustainable development Energy Crisis: Renewable Energy Resources, Environmental degradation and pollution. Eco-friendly Technologies. Environmental Regulations, Environmental Ethics
Appropriate Technology, Movement of Schumacher; Problems of man, machine, interaction.

Text / Reference Books:

1. Stephen H Unger, Controlling Technology: Ethics and the Responsible Engineers, John Wiley & Sons, New York 1994 (2nd Ed)
2. Deborah Johnson, Ethical Issues in Engineering, Prentice Hall, Englewood Cliffs, New Jersey 1991.
3. A N Tripathi, Human values in the Engineering Profession, Monograph published by IIM, Calcutta 1996.

CO-PO MAPPING

CO	PO-1	PO-2	PO-3	PO-4	PO-5	PO-6	PO-7	PO-8	PO-9	PO-10	PO-11	PO-12
Co-1	—	—	—	—	—	1	1	1	1	2	—	—
Co-2	—	—	—	—	—	1	1	3	1	2	—	—
Co-3	—	—	—	—	—	3	2	3	—	1	—	—
Co-4	—	—	—	—	—	3	2	1	—	—	—	—
Co-5	—	—	—	—	—	3	2	2	—	1	3	—

Paper Name: Soft Computing

Code: CS 702A

Contacts: 3L

Credits: 3

Allotted hours: 38L

Prerequisite:

11. A solid background in mathematical and programming Knowledge

Course Objective(s)

CS702A.2			2									
CS702A.3	1		3									
CS702A.4	2											
CS702A.5		1				3						

Name of the Paper: Natural Language Processing

Paper Code: CS702B

Contact (Periods/Week):=3L/Week

Credit Point: 3

No. of Lectures: 41

Prerequisite:

- 12. A solid background in mathematics, including probability, set theory.
- 13. Determination to learn new and difficult things.

Course Objective(s)

- To learn the basics of NLP.
- To learn the principles and application of different NLP techniques.
- To learn the details of NLP algorithms, different tools and knowing their use.

Course Outcome(s)

On completion of the course students will be able to

CS702B.1 Understand the fundamental concept of NLP, Regular Expression, Finite State Automata along with the concept and application of word tokenization, normalization, sentence segmentation, word extraction, spell checking in the context of NLP.

CS702B.2 Understand the concept of Morphology such as Inflectional and Derivational Morphology and different morphological parsing techniques including FSTs.

CS702B.3 Understand the concepts related to language modeling with introduction to N-grams, chain rule, smoothing, Witten Bell discounting, backoff, deleted interpolation, spelling and word prediction and their evaluation along with the concept of Markov chain, HMM, Forward and Viterbi algorithm, POS tagging.

CS702B.4 Understand the concept of different text classification techniques, sentiment analysis, concepts related to CFG in the context of NLP.

CS702B.5 Understand the concept of lexical semantics, lexical dictionary such as WordNet, lexical computational semantics, distributional word similarity and concepts related to the field of Information Retrieval in the context of NLP.

Module I: [12L]

Introduction to NLP [2L]

Human languages, models, definition of NLP, text representation in computers, encoding schemes, issues and strategies, application domain, tools for NLP, Linguistic organisation of NLP, phase in natural language processing, applications

Regular Expression and Automata [2L]

Finite State Automata. Introduction to CFG and different parsing techniques.

Tokenization [4L]

Word Tokenization, Normalization, Sentence Segmentation, Named Entity Recognition, Multi Word Extraction, Spell Checking – Bayesian Approach, Minimum Edit Distance

Morphology [4L]

Morphology – Inflectional and Derivational Morphology, Finite State Morphological Parsing, The Lexicon and Morphotactics, Morphological Parsing with Finite State Transducers, Orthographic Rules and Finite State Transducers, Porter Stemmer.

Module II: [9L]

Language Modeling [4L]

Introduction to N-grams, Chain Rule, Smoothing – Add-One Smoothing, Witten-Bell Discounting; Backoff, Deleted. Interpolation, N-grams for Spelling and Word Prediction, Evaluation of language models. Spelling errors, detection and elimination using probabilistic models, pronunciation variation (lexical, allophonic, dialect), decision tree model, counting words in Corpora

Hidden Markov Models and POS Tagging [5L]

Markov Chain, Hidden Markov Models, Forward Algorithm, Viterbi Algorithm, Part of Speech Tagging – Rule based and Machine Learning based approaches, concept of HMM tagger Evaluation. Handling of unknown words, named entities, multi word expressions.

Module III: [9L]

Text Classification [4L]

Text Classification, Naïve Bayes' Text Classification, Evaluation, Sentiment Analysis – Opinion Mining and Emotion Analysis, Resources and Techniques.

Context Free Grammar [5L]

Context Free Grammar and Constituency, Some common CFG phenomena for English, Top-Down and Bottom-up parsing, Probabilistic Context Free Grammar, Dependency Parsing

Module IV: [11L]

Computational Lexical Semantics [5L]

Introduction to Lexical Semantics – Homonymy, Polysemy, Synonymy, Thesaurus – WordNet, VerbNet, Computational Lexical Semantics – Thesaurus based and Distributional Word Similarity, Lexemes (homonymy, polysemy, synonymy, hyponymy), word structure, metaphor, metonymy. Word sense disambiguation, machine learning approaches, dictionary based approaches.

Information Retrieval [6L]

Boolean Retrieval, Term-document incidence, The Inverted Index, Query Optimization, Phrase Queries, Ranked Retrieval, Term Frequency and Inverse Document Frequency based ranking, Zone Indexing, Query term proximity, Cosine ranking, Combining different features for ranking, Search Engine Evaluation, Relevance Feedback.

Resource management with XML, Management of linguistic data with the help of GATE, NLTK

Text books:

1. D. Jurafsky & J. H. Martin – —Speech and Language Processing – An introduction to Language processing, Computational Linguistics, and Speech Recognition, Pearson Education
2. Chris Manning and Hinrich Schütze, -Foundations of Statistical Natural Language Processing, MIT Press. Cambridge, MA: May 1999.

Reference books:

1. Allen, James. 1995. – —Natural Language Understanding. Benjamin/Cummings, 2ed.
2. Bharathi, A., Vineet Chaitanya and Rajeev Sangal. 1995. Natural Language Processing- —A Pananian Perspectivel. Prentice Hill India, Eastern Economy Edition.

CO-PO Mapping

CO	PO1	PO2	PO3	PO4	PO5	PO6	PO7	PO8	PO9	PO10	PO11	PO12	CO	PO1	PO2
CS702B.1		2	3	3	3						3	2	3	2	3
CS702B.2		2	2	2	1						3	2	3	2	2
CS702B.3		2	3	3	3	3					3	2	3	2	2
CS702B.4		2	2	2	1						3	2	3	2	2
CS702B.5	3				2	3	1						2	2	3
CS702B	3	2	3	3	2	3	1	-	-	-	3	2	3	2	2

Name of the Paper: Web Technology**Paper Code: CS702C****Contact (Periods/Week): 3L/Week****Credit Point: 3****No. of Lectures: 35****Prerequisites:**

1. Fundamentals of Programming
2. Concepts of Networking

Course Objective(s):

- To impart the design, development and implementation of Static and Dynamic Web Pages.
- To develop programs for Web using Scripting Languages and .net framework.
- To give an overview of Server Side Programming in Web

Course Outcome(s) (CO):

CS702C.1 To understand the notions of World Wide Web(www), Internet, HTTP Protocol, Web Browsers, Client-Server etc.

CS702C.2 To develop interactive web pages using HTML, DHTML and CSS.

CS702C.3 To procure the knowledge of different information interchange formats like XML.

CS702C.4 To design web applications using scripting languages like JavaScript, CGI, PHP.

CS702C.5 To acquire the server side programming concepts using servlet, JSP and .Net framework.

Module 1: [4L]

Introduction to Web[4L]: Concept of World Wide Web (www), Internet and the relation with www[1L];The Internet - Basic Internet Protocols, HTTP Protocol - Request and Response, Web browser [1L]; Web clients and Web servers, Dynamic IP[1L]; Clients, Servers, and Communication, Web site design principles, Planning the site and navigation[1L].

Module -2: [9L]

HTML, DHTML & CSS [6L]: Introduction, Elements, Attributes, Heading, Paragraph. Formatting[1L]; Link, Table, List, Block, Layout, Html Forms and input [1L]; Iframe, Colors, Image Maps and attributes of image area [2L];Introduction to CSS, basic syntax and structure of CSS, different types- internal, external and inline CSS[1L];Basic Introduction of DHTML, Difference between HTML and DHTML, Documentary Object Model (DOM) [1L].

Extended Markup Language (XML) [3L]: Introduction, Difference between HTML & XML, XML-Tree [1L]; Syntax, Elements, Attributes, Validation and parsing, DTD[2L].

Module 3: [8L]

Java Scripts[3L]:Basic Introduction, Statements, comments, variable, operators, data types[1L]; condition, switch, loop, break [1L]; Java script functions, objects and events[1L].

CGI Scripts [1L]: Introduction, Environment Variable, GET and POST Methods.

PHP Scripting [4L]: Introduction, Syntax, Variables, Output, Data types, String, Constants[1L]; Operator, Decision Control statements[1L]; switch-case, Loop, PHP function[1L]; array, Form Handling[1L].

Module-4: [14L]

Java Server Page (JSP) [8L]:

JSP Architecture [1L]; JSP Servers , JSP Life Cycle [1L]; Understanding the layout of JSP, JSP Scriptlet Tag[1L]; JSP implicit object (request and response) [1L]; Variable declaration, methods in JSP [1L];JSP directive (Taglib and Include), Javabean- inserting javabean in JSP [1L];JSP Action tags (Forward & Include) [1L]; Creating ODBC data source name, Introduction to JDBC, prepared statement and callable statement [1L].

Java Servlet [3L]: Servlet environment and role, Servlet life cycle [1L]; Servlet methods- Request, Response, Get and post [1L];Cookies and Session [1L].

.NET Framework [3L]: ASP.Net with MVC introduction, MVC Architecture, MVC routing, controller, Action method, Action Selector and Action verb, Model and View [1L];.net framework, C#.net introduction, environment variable, basic syntax of conditional statement, loop and function[2L].

Text Books:

1. -Web Technology: A Developer's Perspective, N.P. Gopalan and J. Akilandeswari, PHI Learning, Delhi, 2013. (Topics covered: html, CSS, imagemap, xml)
2. -Learning PHP, MySQL & JavaScript, Robin Nixon, O'Reilly Publication.(Topics covered: PHP, Java Script)
3. -Head First Servlet's & JSP, Bryan Basham, Kathy Sterra, Bert Bates, O'Reilly Publication.(Topics covered: Servlet, JSP)
4. ASP.NET Core 2.0 MVC And Razor Pages For Beginners, Jonas Frajerberg, O'Reilly Publication.(Topics covered: MVC, ASP.Net, C#)

Recommended books:

1. "Programming the World Wide Web", Robert. W. Sebesta, Fourth Edition, Pearson Education, 2007.
2. Core Web Programming- Second Edition-Volume I and II, Marty Hall and Larry Brown, Pearson Education, 2001.

	PO1	PO2	PO3	PO4	PO5	PO6	PO7	PO8	PO9	PO10	PO11	PO12
C01	1	-	2	-								
C02	-	2	3	2								
C03	-	2	2	-								
C04	1	2	3	2								
C05	1	-	3	2								

PaperName:CloudComputing

Code:CS703A

Contacts:3L ; Credits:3

Allottedhours:35L

PREREQUISITE

- Should have the basic knowledge of Operating Systems and Virtualization Technologies
- Should aware of the fundamental concepts of Networking
- Should have knowledge of heterogeneous systems and resource management.

COURSE OBJECTIVES

- To learn the work-flow of cloud business model and optimized resource allocation.
- To gain knowledge of cloud service and delivery models and develop an understanding of the risk and compliance responsibilities and Challenges for each Cloud type and service delivery model.
- To learn virtualization techniques, load balancing, and work strategy of different cloud infrastructure.
- To know the security and privacy issues in cloud infrastructure.

COURSE OUTCOMES

After completion of course, students would be able to:

CS703A.1 Articulate the business model concepts, architecture and infrastructure of cloud computing, including cloud service models and deployment models.

CS703A.2 Apply and design suitable Virtualization concept, Cloud Resource Management and design scheduling algorithms

CS703A.3 Explore some important cloud computing driven commercial systems such as Google Apps, Microsoft Azure and Amazon Web Services and other businesses cloud applications

CS703A.4 Analyze the core issues of cloud computing such as security, privacy, interoperability, and its impact on cloud application

Module 1: Definition of Cloud Computing and its Basics [8L]

1. Definition of Cloud Computing: Defining a Cloud, Cloud Types – NIST model, Cloud Cube model, Deployment models (Public , Private, Hybrid and Community Clouds), Service models – Infrastructure as a Service, Platform as a Service, Software as a Service with examples of services/ service providers, Cloud Reference model, Characteristics of Cloud Computing – a shift in paradigm Benefits and advantages of Cloud Computing **[3]**

2. Cloud Architecture: Cloud Infrastructure, Architecture of each components, Virtualization versus Traditional Approach, Virtualization Model for Cloud Computing. **[2]**

3. Services and Applications by Type**[3]**

IaaS – Basic concept, Workload, partitioning of virtual private server instances, Pods, aggregations, silos

PaaS – Basic concept, tools and development environment with examples
SaaS - Basic concept and characteristics, Open SaaS and SOA, examples of SaaS platform
Identity as a Service (IDaaS) Compliance as a Service (CaaS)

Module 2: Use of Platforms in Cloud Computing [6L]

1. Concepts of Abstraction and Virtualization [2]

Virtualization technologies: Types of virtualization, Load Balancing and Virtualization: Basic Concepts, Network resources for load balancing; Classification of Virtualization Environment: Scheduling-based Environment, Load-Distribution-Based Environment, Energy Aware-Based Environment, Operational-Based Environment, Distributed Pattern-Based Environment, Transactional-Based Environment

2. Mention of The Google Cloud as an example of use of load balancing Hypervisors: Virtual machine technology and types, VMware vSphere Machine imaging (including mention of Open Virtualization Format – OVF) [2]

Porting of applications in the Cloud: The simple Cloud API and AppZero Virtual Application appliance

3. Concepts of Platform as a Service [2]

Definition of services, Distinction between SaaS and PaaS (knowledge of Salesforce.com and Force.com), Application development. Use of PaaS Application frameworks

Module 3 : Cloud Service Models [6L]

1. Use of Google Web Services [2L]

Discussion of Google Applications Portfolio – Indexed search, Dark Web, Aggregation and disintermediation, Productivity applications and service, Adwords, Google Analytics, Google Translate, a brief discussion on Google Toolkit (including introduction of Google APIs in brief), major features of Google App Engine service.

2. Use of Amazon Web Services [2L]

Amazon Web Service components and services: Amazon Elastic Cloud, Amazon Simple Storage system, Amazon Elastic Block Store, Amazon SimpleDB and Relational Database Service

3. Use of Microsoft Cloud Services [2L]

Windows Azure platform: Microsoft's approach, architecture, and main elements, overview of Windows Azure AppFabric, Content Delivery Network, SQL Azure, and Windows Live services

Module 4 : Cloud Infrastructure [10L]

Types of services required in implementation – Consulting, Configuration, Customization and Support

1. Cloud Management [3L]

An overview of the features of network management systems and a brief introduction of related products from large cloud vendors, Monitoring of an entire cloud computing deployment stack – an overview with mention of some products, Lifecycle management of cloud services (six stages of lifecycle)

2. Live Migration of Virtual Machines: [2L]

Need of Live Migration of Virtual Machine, A Designing Process of Live Migration, and Security Issues during live migration

3. Concepts of Cloud Security [3L]

Infrastructure Security, Infrastructure Security: The Network Level, The Host Level, The Application Level, Data Security and Storage, Aspects of Data Security, Data Security Mitigation Provider Data and Its Security, Identity and Access Management

4. Auditing and Compliance in Cloud Environment: [2L]

Data Security in Cloud Computing Environment, Need for Auditing in Cloud Computing Environment, Third Party Service Provider, Cloud Auditing Outsourcing Lifecycle Phases, Auditing Classification.

Module 5 : Concepts of Services and Applications [5L]

1. Service Oriented Architecture: Basic concepts of message-based transactions, Protocol stack for an SOA architecture, Event-driven SOA, Enterprise Service Bus, Service catalogs [1]

2. Applications in the Cloud: Concepts of cloud transactions, functionality mapping, Application attributes, Cloud service attributes, System abstraction and Cloud Bursting, Applications and Cloud APIs [2]

3. Cloud-based Storage: Cloud storage definition – Manned and Unmanned. [1]

4. Webmail Services: Cloud mail services including Google Gmail, Mail2Web, Windows Live Hotmail, Yahoo mail, concepts of Syndication services [1]

Books Recommended:

1. *Mastering Cloud Computing* by Rajkumar Buyya, Christian Vecchiola, S. Thamarai Selvi, McGraw Hill Education (India) Private Limited, 2013

2. *Fundamentals of Cloud Computing* by P. K. Pattnaik, S. Pal, M. R. Kabat, Vikas Publications, 2014.

References:

1. *Cloud Computing Bible* by Barrie Sosinsky, Wiley India Pvt. Ltd, 2013

2. *Cloud computing: A practical approach*, Anthony T. Velte, Tata McGraw-Hill

CO-PO Mapping

CO	PO1	PO2	PO3	PO4	PO5	PO6	PO7	PO8	PO9	PO10	PO11	PO12
CS703A.1				2								
CS703A.2			1				1				3	
CS703A.3						2			2			
CS703A.4								2	1			

Name of the Paper: Data Analytics

Paper Code: CS703B

Contact (Periods/Week):=3L/Week

Credit Point: 3

No. of Lectures: 40

Prerequisite:

14. Familiarity and knowledge of Database Management Systems
15. Familiarity and knowledge of Database Management Systems Laboratory.

Course Objective(s)

1. Conceptualization and summarization of big data and trivial data versus big data
2. Big data computing technologies.
3. Help students learn, understand, and practice big data analytics with distributed approaches.
4. Learn and understand different programming model of big data.

Course Outcome(s)

CS703B.1: Identify the difference between structured, semi-structured and unstructured data.

CS703B.2: Summarize the challenges of big data and how to deal with the same.

CS703B.3: Explain the significance of NoSQL databases.

CS703B.4: Explain about Hadoop Ecosystem.

CS703B.5: Identify the difference between Pig and Hive

Module I: DATA AND BIG DATA ANALYTICS [6L]

Introduction (2L):

Types of digital data [1L]: Structured: Sources of structured data and Ease with Structured data Semi-Structured: sources of semi-structured data Unstructured: sources of unstructured data: Issues with terminology, dealing with unstructured data.

Big data analytics-1 [2L]: Characteristics of data-Definition of big data-Challenges of big data Traditional BI vs. Big data-A typical BI environment-A big data environment-Big data stack

Big data analytics-2 [1:]: Classification of analytics-Top challenges facing big data-Data science.

Terminologies used in big data environment [2L]: In memory analytics-In database processing. Massively parallel processing-Parallel vs distributed systems-Shared Memory architecture CAP

(Consistency, Availability, Partition Tolerance) theorem explained- BASE (Basically Available Soft State Eventual Consistency)-Few top Analytics tools.

Module II: BIG DATA TECHNOLOGY AND HADOOP [8L]

The big data technology landscape [1]: NoSQL-Types of NoSQL databases-Why NoSQL -Advantages of NoSQL- What we miss with NoSQL?- NoSQL Vendors SQL Vs. NoSQL. NewSQL - Comparison of SQL, NoSQL and NewSQL.

Hadoop [1] : Features of Hadoop- Key advantages of Hadoop- Versions of Hadoop-Hadoop 1.0 Hadoop 2.0- Overview of Hadoop Ecosystems- Hadoop Vs. SQL- Integrated Hadoop systems offered by leading market vendors-Cloud based Hadoop solutions.

Introducing Hadoop [2]: Why not RDBMS-Distributed Computing Challenges. Hadoop Overview: Hadoop Components-High Level Architecture of Hadoop. Hadoop Distributed File System: HDFS Architecture-Daemons Related to HDFS- Working with HDFS Command-Special Features of Hadoop.

Processing Data With Hadoop [2]: Introduction-How Map Reduce Works-Map Reduce Example. Word Count Example using Java.

Managing Resources and Applications with YARN [2] : Introduction-Limitation of Hadoop 1.0- Hadoop 2: HDFS-Hadoop 2: YARN-Business Intelligence on Hadoop

Module III: NOSQL – MONGODB AND CASSANDRA [9L]

NoSQL – MongoDB [4] : What is MongoDB? - Using JSON-Creating or generating a unique key Support for dynamic queries- Storing binary data-Replication-Sharding-Updating information in-place. Terms used in RDBMS and MongoDB-Data types in MongoDB-MongoDB - CRUD (Insert (), Update (), Save (), Remove (), find ())-MongoDB- Arrays, Java Scripts, Cursors, Map Reduce Programming, Aggregations.

NoSQL – Cassandra [4] : What is Cassandra?-Why Cassandra?- Peer to peer network-Gossip and Failure detection- Anti-Entropy & Read Repair- Writes in Cassandra- Hinted handoffsTunable consistency. Cassandra- CQLSH - CRUD, Counter, List, Set, Map, Tracing.
NoSQL – MongoDB Vs. NoSQL – Cassandra [1L]

Module IV: HADOOP HIVE [9L]

Introduction to Hive - The Problem Solution [3]: Hive Use Case- Data Growth- Schema Flexibility and Evolution- Extensibility. What is Hive: History of Hive and Recent Releases of Hive-Hive Features-Hive Integration and Work Flow- Hive Data Units.

Hive Architecture-Hive Primitive Data Types and Collection Types-Hive File Formats-Hive Query Language Statements: DDL-DML. Hive Partitions-Bucketing-Views-Sub Query-Joins Hive User Defined Function-Aggregations in Hive-Group by and Having-Serialization and Deserialization-Hive Analytic Functions. [6L]

Module V: HADOOP – PIG [8L]

Hadoop – Pig: Introducing Pig [2L] : History and Anatomy of Pig-Pig on Hadoop-Pig Features-Pig Philosophy-Word count example using Pig-Use Case for Pig-Pig Primitive Data Types , Collection Types and NULL.

Pig Latin Overview [2L]: Pig Latin Grammar - Comments, Keywords, Identifiers-Case sensitivity in Pig-Common Operators in Pig.

Pig Statements [1L]: LOAD-STORE-DUMP-Interactive Shell – GRUNT: FILTER- SORTGROUP BY-ORDER BY-JOIN-LIMIT.

Pig Latin Script [2L]: Local Mode-Map Reduce Mode-Running Pig Script. Working with: Field Tuple-Bag. User Defined Function-Parameters in Pig.

Jasper Report using Jasper soft studio: Introduction to Jasper Report using Jasper Soft Studio Reporting using MongoDB-Reporting using Cassandra [1L]

Text books:

1. Mark Dexter, Louis Landry, “Joomla Programming”, 2012 Pearson Education.
2. Seema Acharya and Subhashini C, “Big Data and Analytics”, Wiley Publication, 2015

Recommended books:

1. Judith Hurwitz, Alan Nugent, Fern Halper, Marcia Kaufman, “Big data for dummies”, Wiley Publication, 2013.
2. Tom White, “Hadoop: The Definitive Guide”, O’Rilly Publication, 2015.
3. Chuck Lam, “Hadoop in action”, Dreamtech Press, 2011.
4. Dirk Deroos, Paul C. Zikopoulos, Roman B. Melnyk, Bruce Brown, “Hadoop for dummies”, Wiley publication, 2015.

Other References:

1. <https://www.mongodb.org>
2. <http://cassandra.apache.org>
3. <http://apache.bytenet.in/hadoop/common/hadoop-2.6.0/>
4. <http://apache.bytenet.in/hive/>
5. <http://apache.bytenet.in/pig/>
6. <https://community.jaspersoft.com>

CO-PO Mapping

CO	PO1	PO2	POP3	PO4	PO5	PO6	PO7	PO8	PO9	PO10	PO11	PO12
CS703B.1		2		2								
CS703B.2					2							
CS703B.3					3							
CS703B.4												
CS703B.5		2			3							

Name of the Paper: Sensor Network and IOT

Paper Code: CS703C

Contact (Periods/Week):3L/Week

Credit Point: 3

No. of Lectures: 35

Prerequisite:

16. Familiar with basic Computer Networks concepts
17. Basic knowledge of Microcontroller fundamentals

Course Objective(s)

- To explore the interconnection and integration of the physical world and the cyberspace
- To understand building blocks of Internet of Things and characteristics
- To design and develop IoT Device

Course Outcomes

- CS703C.1** To analyze basic protocols in wireless sensor network
- CS703C.2** To understand the concepts of Internet of Things
- CS703C.3** To recognize the M2M communication protocols
- CS703C.4** To design IoT applications in different domain on embedded platform and be able to analyze their performance

Module -1: [11L]

Wireless Sensor Networks Fundamentals

Wireless medium access issues [1L]

MAC Protocols for Wireless Sensor Networks, Low Duty Cycle Protocols And Wakeup Concepts - S-MAC , The Mediation Device Protocol, Wakeup Radio Concepts, Contention based protocols(CSMA,PAMAS) [2L]

Schedule based protocols (LEACH, SMACS, TRAMA) Address and Name Management in WSNs, Assignment of MAC Addresses [2L]

Routing Protocols- Energy-Efficient Routing, Geographic Routing, Hierarchical networks by clustering. [2L]

Sensor deployment & Node discovery [2L]

Data aggregation & dissemination [2L]

Module -2: [6L]

Fundamentals on IoT

Definition of IoT and Characteristics of IoT [1L]

Physical and logical design of IoT [2L]

Functional blocks of IoT [1L]

Communication models & APIs: Internet connectivity, Internet-based communication, IPv4, IPv6, 6LoWPAN protocol, IP Addressing in the IoT, Application layer protocols: HTTP, HTTPS, FTP, TELNET and ports. [2L]

Module 3: [7L]

Message to Message Communication and IoT

M2M communication and Modified OSI Model for the IoT/M2M Systems [1L]

Data enrichment, data consolidation and device management at IoT/M2M Gateway [2L]

Web communication protocols used by connected IoT/M2M devices [2L]

Message communication protocols (CoAP-SMS, CoAP-MQ, MQTT, XMPP) for IoT/M2M devices [2L]

Module -4: [11L]

IoT Prototyping and Security

Introduction to Prototyping Embedded device software [1L]

Programming Embedded Device Arduino Platform using IDE [1L]

Reading data from sensors and devices, Devices, Gateways [2L]

Internet and Web/Cloud services software development [1L]

Programming MQTT clients and MQTT server [2L]

Introduction to IoT privacy and security [2L]

Vulnerabilities, security requirements and threat analysis [1L]

Domain specific applications of IoT [1L]

Text Books:

1. Vijay Madiseti, Arshdeep Bahga, -Internet of Things: A Hands-On Approach, Orient BlackSwan
2. Walteneus Dargie, Christian Poellabauer, "Fundamentals of Wireless Sensor Networks: Theory and Practice", Wiley

Recommended books:

1. David Hanes, Gonzalo Salgueiro, Patrick Grossetete, Rob Barton, Jerome Henry, Rowan Trollope, -IoT Fundamentals : Networking Technologies, Protocols and Use Cases for the Internet of Things, Pearson
2. C. Siva Ram Murthy, B. S. Manoj, -Ad Hoc Wireless Networks: Architectures and Protocols, Prentice Hall

CO-PO Mapping

CO	PO1	PO2	PO3	PO4	PO5	PO6	PO7	PO8	PO9	PO10	PO11	PO12
CS703C.1	3	2	3	3	3							
CS703C.2	3	2			3							
CS703C.3	3	2	2									
CS703C.4	3	3	3	3	3	3	3					

Name of the Paper: Distributed Algorithms

Paper Code: CS 704(A)

Contact (Periods/Week):=3L/Week

Credit Point: 2

No. of Lectures: 35

Prerequisite:

18. Familiarity with the basic concept of Algorithm and protocols
19. A solid background in mathematics, including probability, connective arithmetic.

Course Objective(s)

- To learn the basic concept of different models of distributed algorithm.
- To learn the principles of Analyze of synchronous, asynchronous and shared allocation techniques.
- To build concepts of shared storage, data links and agreement mechanisms for algorithms.

Course Outcome(s)

On completion of the course students will be able to

CS-704(A).1: Acquire a basic concept of different models and organizational structure of distributed algorithm

CS-704(A).2: Analyze basic idealization of synchronous, asynchronous and shared allocation techniques

CS-704(A).3: Understand different models of synchronous, asynchronous allocation techniques in the light of implementation in network and memories.

CS-704(A).4: Explain the concepts of shared storage, data links and agreement mechanisms along with its failure detection technique for algorithms.

CS-704(A).5: Concept of advance application and development of partial and distributed algorithms in timed based proof, protocols and methods along with its perspective in modern computing era.

MODULE– I [TOTAL – 7L]

Introduction to Distributed Algorithms, Kinds of Distributed Algorithm (**1L**);

Timing Models (**1L**),

Synchronous Network Algorithms: Synchronous Network Model, (**1L**);

Leader Election in a synchronous Ring (**1L**);

Algorithms in General Synchronous Networks (**1L**);

Distributed Consensus with Link Failures, Distributed Consensus with Process failures (1L);
More Consensus problems (1L)

MODULE – II [TOTAL – 5L]

Asynchronous System and network Model (2L);
Shared Memory Algorithms and Model (1L);
Mutual Exclusion, Resource Allocation (1L);
Consensus; Atomic Objects (1L)

MODULE – III [TOTAL – 5L]

Basic Network Algorithms (2L);
Synchronizers, Shared Memory versus Networks (2L);
Logical Time, Global Snapshots and Stable properties (1L)

MODULE – IV [TOTAL – 11L]

Network Resource Allocation: Mutual Exclusion, General Resource Allocation (2L);
Process Failures: Network methodology (1L);
Impossibility of Agreement in the presence of Faults, A Randomized Algorithm (2L);
Failure Detectors, Approximate Agreement (2L);
Data Link Protocols: The Problem, Stenning's Protocol (2L);
Alternating Bit Protocol (1L);
Bounded Tag protocols tolerating Reordering, Tolerating Crashes (1L)

MODULE – V [TOTAL – 7L]

Partially Synchronous Algorithms: Partially Synchronous System Models: MMT and General
Timed Automata (2L);
Properties and Proof methods, Modeling Shared Memory and Network Systems (2L);
Mutual Exclusion with Partial Synchrony: A single-register algorithm (1L);
Resilience to Timing Failures, Consensus with partial Synchrony: An Efficient algorithm (2L).

Text Book:

1. Joseph Jaja, -**An Introduction to Parallel Algorithms**||, Addison Wesley
2. Nancy A. Lynch, -**Distributed Algorithms**||, Morgan Kaufmann Publishers, 2000
3. A.D. Kshemkalyani, M. Singhal, -**Distributed Computing: Principles, Algorithms, and Systems**||, Cambridge University Press, March 2011.

References

1. Gerald Tel, -**Introduction to Distributed algorithms**||, 2nd Edition, Cambridge, 2004
2. Nicola Santoro, -**Design and Analysis of Distributed Algorithms**||, Wiley Inter-science, John Wiley & Sons, Inc., Publication, 2007.

CO-PO Mapping

CO/PO Mapping Table (S/M/W indicates strength of correlation) S-Strong, M-Medium, W-Weak)												
COs	Program Outcomes (POs)											
	PO1	PO2	PO3	PO4	PO5	PO6	PO7	PO8	PO9	PO10	PO11	PO12
CO1		3		3								
CO2		3	2					3				
CO3	2			1						1		
CO4		2	1									1
CO5		1		3	2							

Name of the Paper: Bio-informatics

Paper Code: CS704B

Contact (Periods/Week): L-T-P=3-0-0

Credit Point: 3

No. of Lectures: 35

OBJECTIVES: The student should be made to:

- Be familiar with the modeling techniques.
- Learn microarray analysis.
- Exposed to Pattern Matching and Visualization.

OUTCOMES: The students will be able to upon completion of the course,

- Develop models for biological data
- Apply pattern matching techniques to bioinformatics data – protein data genomic data.
- Apply micro array technology for genomic expression study

Course Outcomes

CS704B.1 To acquire the knowledge of Bioinformatics technologies with the related concept of DNA, RNA and their implications

CS704B.2 To develop idea in MOLECULAR BIOLOGY

CS704B.3 To understand the concept and techniques of different types of Data Organization and Sequence Databases with different types of Analysis Tools for Sequence Data Banks

CS704B.4 To acquire the knowledge of the DNA SEQUENCE ANALYSIS

CS704B.5 To analyze the performance of different types of Probabilistic models used in Computational Biology

Module -1: [7L]

INTRODUCTION TO MOLECULAR BIOLOGY:

Concepts of Cell, tissue, types of cell, components of cell, organelle. Functions of different organelles.

Concepts of DNA: Basic Structure of DNA; Double Helix structure; Watson and crick model. Exons and Introns and Gene Concept.

Concepts of RNA : Basic structure, Difference between RNA and DNA. Types of RNA.

Concept of Protein: Basic components and structure. Introduction to Central Dogma:

Transcription and Translation, Introduction to Metabolic Pathways.

Introduction to Bioinformatics. Recent challenges in Bioinformatics.

Module -2: [10L]

Introduction to Genomic data, Data Organization and Sequence Databases: Sequence Data Banks - Introduction to sequence data banks - protein sequence data bank. Signal peptide data bank, Nucleic acid sequence data bank - GenBank, AIDS virus sequencedata bank. RRNA data bank, structural data banks - protein Data Bank (PDB), The Cambridge Structural Database (CSD) : Genome data bank - Metabolic pathway data : Microbial and Cellular Data Banks.

Introduction to MSDN (Microbial Strain Data Network): Numerical Coding Systems of Microbes, Hibridoma Data Bank Structure, Virus Information System Cell line information system; Protein Sequence Databases, DNA sequence databases. sequence database search programs like BLAST and FASTA. NCBI different modules: GenBank; OMIM, Taxonomy browser, PubMed;

Module 3: [8L]

DNA SEQUENCE ANALYSIS

DNA Mapping and Assembly : Size of Human DNA ,Copying DNA: Polymerase Chain Reaction (PCR), Hybridization and Microarrays, Cutting DNA into Fragments, Sequencing Secondary Structure predictions;

prediction algorithms; Chao-Fasman algorithm, Hidden-Markov model, Neural Networking.

Tertiary Structure predictions;

prediction algorithms; Chao-Fasman algorithm, Hidden-Markov model, Neural Networking

Module -4: [10L]

Introduction Probabilistic models used in Computational Biology:

Probabilistic Models;

Gene Regulatory Method Application of HMM in Bioinformatics : Genefinding, profile searches, multiple sequence alignment and regulatory site identification.

Applications in Biotechnology

: Protein classifications, Fold libraries, Protein structure prediction: Fold recognition

(threading), Protein structure predictions : Comparative modeling (Homology), Advanced topics:

Protein folding, Protein-ligand interactions, Molecular Modeling & Dynamics, Drug Designing.

TEXT BOOK:

- Yi-Ping Phoebe Chen (Ed), -BioInformatics Technologiesl, First Indian Reprint, Springer Verlag, 2007.

REFERENCES:

- Bryan Bergeron, -Bio Informatics Computingll, Second Edition, Pearson Education, 2003.
- Arthur M Lesk, -Introduction to Bioinformaticsll, Second Edition, Oxford University Press, 2005

CO-PO Mapping

CO	PO1	PO2	PO3	PO4	PO5	PO6	PO7	PO8	PO9	PO10	PO11	PO12
CS704B.1	3					1	1					
CS704B.2		1	2	1								1
CS704B.3	1	2		2	2				1			
CS704B.4	2					2	2			1	1	
CS704B.5		3		1		3		1				

Name of the Paper: Cryptography and Network Security

Paper Code: CS704C

Contact (Periods/Week):3L/Week

Credit Point: 3

No. of Lectures: 35

Prerequisite:

20. Knowledge of Computer Networksand Operating Systems fundamentals

21. Understanding of Discreet Mathematics concepts

Course Objective(s)

- To impart concepts on cryptography and Network security
- To gain knowledge ofthe standard algorithms used to provide confidentiality, integrity, and authenticity
- To recognize the various key distribution and management systems for security of a cryptosystem

Course Outcomes

- **CS704C.1** To understand the basic concepts in cryptography

- **CS704C.2** To apply the deployment of different encryption techniques to secure messages in transit across data networks
- **CS704C.3** To discuss various techniques used to assure Integrity and Authentication
- **CS704C.4** To analyze diverse security measures and issues in practice

Module -1: [6L]

INTRODUCTION AND NUMBER THEORY

Introduction - Services, Mechanisms, and Attacks, OSI security architecture, Network security model [1L]

Classical Encryption techniques (Symmetric cipher model, substitution techniques, transposition techniques, steganography) [1L]

Finite Fields and Number Theory: Groups, Rings, Fields, Modular arithmetic, Euclid's algorithm [2L]

Finite fields, Polynomial Arithmetic, Prime numbers, Fermat's and Euler's theorem [1L]

Testing for primality - The Chinese remainder theorem - Discrete logarithms [1L]

Module -2: [8L]

BLOCK CIPHERS AND PUBLIC KEY CRYPTOGRAPHY

Data Encryption Standard- Block cipher principles, block cipher modes of operation [2L]

Advanced Encryption Standard (AES), Triple DES, Blowfish, RC5 algorithm [2L]

Public key cryptography: Principles of public key cryptosystems, The RSA algorithm [2L]

Key management - Diffie Hellman Key exchange, Elliptic curve arithmetic, Elliptic curve cryptography [2L]

Module 3: [6L]

HASH FUNCTIONS AND DIGITAL SIGNATURES

Authentication requirement, Authentication function, MAC, Hash function [2L]

Security of hash function and MAC, MD5, SHA, HMAC, CMAC [2L]

Digital signature and authentication protocols, DSS, ElGamal, Schnorr [2L]

Module -4: [9L]

SECURITY PRACTICE AND SYSTEM SECURITY

Authentication applications, Kerberos, X.509 [1L]

Authentication services, Internet Firewalls for Trusted System: Roles of Firewalls [1L]

Firewall related terminology- Types of Firewalls [1L]

Firewall designs principles, SET for E-Commerce Transactions [2L]

Intruder, Intrusion detection system [1L]

Virus and related threats, Countermeasures [1L]

Trusted systems, Practical implementation of cryptography and security [2L]

Module -5: [6L]

E-MAIL, IP, AND WEB SECURITY

E-mail Security: Security Services for E-mail-attacks possible through E-mail, Establishing key privacy, authentication of the source [1L]

Message Integrity, Non-repudiation, Pretty Good Privacy, S/MIME [1L]

IP Security: Overview of IPSec, IPv4 and IPv6-Authentication Header, Encapsulation Security Payload (ESP) [1L]

Internet Key Exchange (Phases of IKE, ISAKMP/IKE Encoding)[1L]
 Web Security: SSL/TLS Basic Protocol, computing the keys, client authentication[1L]
 PKI as deployed by SSL Attacks fixed in v3, Exportability, Encoding, Secure Electronic Transaction[1L]

Text Books:

3. Atul Kahate, -Cryptography and Network Security, Third edition, McGraw Hill Education

Recommended books:

3. William Stallings, -Cryptography and Network Security: Principles and Practice, Sixth edition, Pearson
4. Behrouz A. Forouzan, Debdeep Mukhopadhyay, -Cryptography and Network Security, Second edition, McGraw Hill Education

CO-PO Mapping

CO	PO1	PO2	PO3	PO4	PO5	PO6	PO7	PO8	PO9	PO10	PO11	PO12
CS704C.1	3		2			3						
CS704C.2	3	2	3	2	3							
CS704C.3		3	2	3								
CS704C.4	2	3		3		3						

Practical

CourseCode:CS791

Course Name: Artificial Intelligence Lab

Objective(s):

- To learn the fundamentals of PROLOG Programming.
- To impart adequate knowledge on the need of PROLOG programming languages and problem solving techniques.

Course Outcome(s):

On completion of the course students will be able to

CS793C.1	Learn the concept of simple programming using PROLOG.
CS793C.2	Understand the concept of AI based programs using PROLOG.
CS793C.3	Develop the capability to represent various real life problem domains using logic based techniques

Syllabus:

Programming Languages such as PROLOG or LISP covering the sample following topics (but not limited to):-

1. Basic computational related programs, e.g., factorial, Fibonacci, GCD etc.
2. Mini program to express the flavour of intelligence, e.g. if any symptoms are given, the disease should be identified using the program
3. Family tree related problem to understand how to apply logic to solve complex problems
4. Programs related to list/array

Mapping with Program Outcomes (POs) and Program Specific Outcomes (PSOs)

CO #	PO1	PO2	PO3	PO4	PO5	PO6	PO7	PO8	PO9	PO10	PO11	PO12
CS791.1	3	3	3	3	3	1	1	1	1	2	3	2
CS791.2	3	3	3	3	3	1	1	1	1	2	3	2
CS791.3	3	3	3	3	3	1	1	1	1	2	3	2
CS791	3	3	3	3	3	1	1	1	1	2	3	2

Paper Name: Soft Computing Lab

Code: CS 792A

Contacts: 3P

Credits: 2

Prerequisite:

22. Familiarity with the Matlab command
23. A solid background in mathematical and programming Knowledge

Course Objective(s)

- To learn the to implement soft computing methods.
- To learn to solve the real world problem through program of Matlab/Python
- To learn to solve and optimize the real world problem using Matlab/Python
- **Course Outcomes**
 - **CS792A.1** To understand the concept and techniques of designing and implementing of soft computing methods in real world problem
 - **CS792A.2** To acquire the knowledge of the fuzzy Neural network and Genetic Language
 - **CS792A.3** To analyze and optimized the problem of real-life applications

Lab

1. Python/Matlab programming introduction.
2. Matlab programming fundamental./Python programming fundamental.
3. Matlab tool box implementation. / Python introduction to numerical calculation programming(scitificpython,Numericalpython,Imageprocessing).
4. Python/Matlab programming to simulate a single layer neural network designs.
5. Python/Matlab programming to simulate multiple layer neural network designs.
6. Python/Matlab programming to observe the perceptron learning algorithm performances for a single layer network. In this experiment consider the XOR dataset.
7. Write a Matlab/python code for maximizing $F(x)=x^2$, where x ranges from say 0 to 31 using Genetic Algorithm.
8. Use of Genetic Algorithm toolbox in matlab for optimization problem solving. Implantation Simple Genetic Algorithm in python for solving optimization problem.
9. Write a Matlab/python program to implement the different Fuzzy Membership functions.
10. Write a Matlab/python program to implement Fuzzy set operations and its properties.

CO-PO Mapping

CO	PO1	PO2	PO3	PO4	PO5	PO6	PO7	PO8	PO9	PO10	PO11	PO12
CS792A.1	1		3									
CS792A.2	2											
CS792A.3		0				3						

Name of the Paper: Natural Language Processing Lab

Paper Code: CS792B

Contact (Periods/Week):=3L/Week

Credit Point: 2

Prerequisite:

24. Familiarity with the programming concepts in any language
25. A solid background in mathematics, including probability, statistics.

Course Objective(s)

- To learn the basics of NLTK toolkit.
- To learn the principles of NLP through programming.
- To build an application using different algorithms and natural language processing techniques.

Course Outcome(s)

On completion of the course students will be able to

CS792B.1 Access text corpora and lexical resources and process of raw text.

CS792B.2 Write structured programs for categorizing and tagging of words, segmentation of sentences.

CS792B.3 Classify text and extract information from it.

CS792B.4Analyze sentence structure and build feature based grammar.

CS792B.5Analyze meaning of sentences and to manage linguistic data.

Module I:

Fundamentals of Python languages, introduction to list, dictionaries etc., input and output handling, saving data to files, retrieving data from files. Writing functions and code reusing. Introduction to working knowledge of matplotlib, SciKit, NumPy and other necessary tools and libraries as per the need.

Module II:

Language processing with python. Manipulating texts and words by writing programs programs. Accessing text corpora, lexical resources,using WordNet through NLTK tool kit. Processing raw text, normalizing, segmenting, applying regular expressions.

Module III:

Writing programs to categorize texts, words, tagging words using tagger, generating tagged tokens, N-Gram tagging, text classification. Writing programs to extract information from texts.

Module IV:

Writing programs to analyze sentence, its meaning etc. Managing linguistic data through programs.

Text books:

1. Steven Bird, Ewan Klein, and Edward Loper. —Natural Language Processing– Analyzing Text with the Natural Language Toolkitl. 2009, O'Reilly, 1ed.

Reference books:

1. Learning Python: Powerful Object-Oriented Programming: 5th Edition by Mark Lutz, 2013, O'Reilly.
2. Natural Language Toolkit documentation (<https://www.nltk.org/>)

CO-PO Mapping

CO	PO1	PO2	POP3	PO4	PO5	PO6	PO7	PO8	PO9	PO10	PO11	PO12	CO	PO1	PO2
CS792B.1	2	1	2	2	2	1	1	1	1	2	2	2	2	1	2
CS792B.2	2	2	2	2	2	2	2	1	1	2	2	2	2	1	2
CS792B.3	2	2	3	3	3	1	1	1	2	2	1	2	2	2	2
CS792B.4	2	2	2	2	2	2	1	1	1	2	1	3	2	2	3
CS792B.5	2	2	3	3	3	2	1	1	1	2	1	3	2	2	3
CS792B	2	2	2	2	2	2	1	1	1	2	1	2	2	2	2

Name of the Paper: Web Technology Lab

Paper Code: CS792C

Contact (Periods/Week): 3P/Week

Credit Point: 2

No. of Lectures: 30

Prerequisite:

1. Fundamentals of Programming.

Course Objective(s)

- To impart the design, development and implementation of Static and Dynamic Web Pages.
- To develop programs for Web using Scripting Languages as well as .net framework.
- To give an overview of Server Side Programming in Web

Course Outcomes

CS792C.1 To develop interactive web pages using HTML, DHTML, CSS and image map.

CS792C.2 To procure the knowledge of information interchange formats like XML.

CS792C.3 To validate fields of web pages using scripting languages like JavaScript.

CS792C.4 To develop web applications using PHP and ASP.net.

CS792C.5 To acquire the server side programming concepts using servlet, JSP.

List of Experiments:

1. Write a single html program through which you can explain a) anchor tag, b)'img' tag with `_src` attribute, c)paragraph d) heading.
2. Write a single html program through which you can draw a table which consists of 3 row and 4 columns where 1st row contains 4 different column fields of a student's information with red text color and Calibri font style with font 12. Rest cells of whole table contain values with blue text colors and Times new roman font style with font 10.
3. Write a single html program where 1st paragraph can collect its specified style from internal stylesheet describes inside that html program and 2nd paragraph can collect its specified style from another file (external stylesheet).
4. Write a single html program which implements image map concept using `_usemap` and `<map>`.

5. Write a html program to find out Celsius temperature of a given Fahrenheit temperature using JavaScript.
6. Write a html program to find out m to the power n (m, n valid integer no) using a function using javascript.
7. Write a xml parsing technique through which parse a text string into an XML DOM object, and extracts the info from it with JavaScript.
8. Write a simple php program through which you can find out maximum and minimum among three no's specified by the user.
9. Write a simple php program through which you can implement the concept of GET & POST method w.r.t PHP Form handling.
10. Write a simple program in ASP.net through which you can create a login page of your own website.
11. Write a simple JSP program through which you can print even and odd no separately within a given range.
12. Create a Online Registration form for individual user of an website using Servlet.

Text Books:

- 1.-Web Technology: A Developer's Perspectivell, N.P. Gopalan and J. Akilandeswari, PHI Learning, Delhi, 2013. **(Topics covered: html, CSS, imagemap, xml)**
- 2.-Learning PHP, MySQL & JavaScriptll, Robin Nixon, O'Reilly Publication.**(Topics covered: PHP, Java Script)**
- 3.-Head First Servlet's & JSPll, Bryan Basham, Kathy Sterra, Bert Bates, O'Reilly Publication.**(Topics covered: Servlet, JSP)**
- 4.ASP.NET Core 2.0 MVC And Razor Pages For Beginners:l, Jonas Frajerberg, O'Reilly Publication.**(Topics covered: ASP.Net, C#)**

Recommended books:

- l. -Web Technologiesll, Black Book, Dreamtech Press
- Core Web Programmingll Second Edition, Marty Hall and Larry Brown, llVolume Iand II, Pearson Education, 2001.

	PO1	PO2	PO3	PO4	PO5	PO6	PO7	PO8	PO9	PO10	PO11	PO12
C01	1	-	2									
C02	2	1	1									
C03	-	2	-	2	-							
C04	-	2	3	-	1							

C05	-	-	3	2	-							
-----	---	---	---	---	---	--	--	--	--	--	--	--

**Department of Computer Science and
Engineering**

Curriculum Structure

&

Syllabus

2016-2017

(Autonomy)

of

8th Semester

8TH SEMESTER								
				Contact hours				Cr. Points
8th Semester				L	T	P	Total	
SL No	Type	Code	A. THEORY					
1	HS	HU805	Principle of Management	2	0	0	2	2
2	PE	CS801A	Mobile Computing	3	0	0	3	3
		CS801B	Human computer Interaction					
		CS801C	Cyber Law and Security Policy					
		CS801D	VLSI Design					
3	PE	CS802A	Parallel Computing	3	0	0	3	3
		CS802B	Machine Learning					
		CS802C	Real Time Operating System and Embedded System					
		CS802D	Advanced Computer Architecture					
Total Theory							8	8
B. PRACTICAL								
4	PC	CS891	Design lab	0	0	3	3	2
5		CS892	Project 2	0	0	12	9	6
6		CS893	Seminar Presentation	0	0	3	3	2
Total Practical							15	10
C. SESSIONAL								
7		CS881	Grand Viva	0	0	0	0	4
Total							26	22
Grand Total								198

Syllabus

Theory

Paper Name: Principles of Management

Paper Code: HU 804

Contact: L-T-P= 2-1-0

Credits: 3

Course Objectives:

1. To develop ability to critically analyze and evaluate a variety of management practices in the contemporary context
2. To understand and apply a variety of management and organizational theories in practice
3. To be able to mirror existing practices or to generate their own innovative management competencies required for today's complex and global workplace
4. To be able to critically reflect on ethical theories and social responsibility ideologies to create sustainable organizations

Course Content:

Unit	Details	Hour
01	Introduction to Management: definitions, managerial roles and functions; Science or Art perspectives- External environment-global, innovative and entrepreneurial perspectives of Management (3 Hrs.)– Managing people and organizations in the context of New Era- Managing for competitive advantage - the Challenges of Management	4
02	Early Contributions and Ethics in Management: Scientific Management- contributions of Taylor, Gilbreths, Human Relations approach–contributions of Mayo, McGregor's Theory, Ouchi's Theory Z .Systems Approach, the Contingency Approach, the Mckinsey 7-S Framework Corporate Social responsibility- Managerial Ethics.	6
03	Planning: Nature and importance of planning, -types of plans (3 Hrs.)- Steps in planning, Levels of planning - The Planning Process. – MBO Organising for decision making: Nature of organizing, organization levels and span of control in management Organisational design and structure –departmentation, line and staff concepts Leading and Controlling: Leading Vs Managing – Trait approach and Contingency approaches to leadership - Dimensions of Leadership (3 Hrs.) - Leadership Behavior and styles – Transactional and Transformational Leadership Basic control processcontrol as a feedback system – Feed Forward Control – Requirements for effective control – control techniques – Overall controls and preventive controls – Global controlling	6
3	Management of Physical Resources Plant: site selection procedures, factors affecting	6

	<p>selection. Layout-types and relative merits and demerits,</p> <p>Maintenance-Objectives, different types of associated decisions, strategies for effective maintenance, computer applications.</p> <p>Material : Functions, objectives, planning and control including inventory models with or without storage costs, price break (excluding dynamic and probabilistic considerations). Different classes of inventory. Material Requirement Planning (MRP)</p>	
4	Quality management: Quality definition, quality planning, quality control and quality management, Total quality management, ISO 9000 systems, simple quality control techniques like control charts and acceptance sampling, Kaizen & Six Sigma	4
5.	Marketing management consumer behavior, market research, product design and development pricing and promotion.	4
	<p>References</p> <p>1. Harold Kooritz & Heinz Weihrich -Essentials of Managementll, Tata McGraw-Hill.</p> <p>2. L.M. Prasad, Principles of Management , Sultan Chand & sons, New Delhi.</p> <p>3. Sherlekar & sherlekar, Principles of Management, Himalaya Publishing House, New Delhi.</p> <p>4. Stephen Robbins, Organizational Behavior, Pearson Education, New Delhi</p> <p>5. Production And Operations Management--K. ASWATHAPPA K. Shridhara Bhat ,Himalayan publishing House</p>	

CO-PO mapping for HU 804

CO	PO-1	PO-2	PO-3	PO-4	PO-5	PO-6	PO-7	PO-8	PO-9	PO-10	PO-11	PO-12
CO-1	-	-	-	-	-	1	1	1	1	2	-	-
CO-2	-	-	-	-	-	1	1	3	1	2	-	-
CO-3	-	-	-	-	-	3	2	-	-	1	-	3
CO-4	-	-	-	-	-		2	1	3	-	-	-

Name of the Paper: Mobile Computing

Paper Code: CS801A

Contact (Periods/Week):=3L/Week

Credit Point: 3

No. of Lectures: 35

Prerequisite:

- 1.Basic concept of computer network and communication engineering
- 2.Basic programming knowledge

Course Objective(s)

- Describe the basic concepts and principles in mobile computing
- To introduce wireless communication and networking principles, that support connectivity to cellular networks, wireless internet and sensor devices.
- Understand positioning techniques and location-based services and security issues

Course Outcome(s)

On completion of the course students will be able to

CS801A.1Analyze the working of modern communication technologies.

CS801A.2Demonstrate the various routing algorithms for both infrastructure based and ad hoc networks.

CS801A.3Develop mobility and bandwidth management in cellular network

CS801A.4Design and build an energy efficient and secure mobile computing environment using heterogeneous wireless technologies

CS801A.5Identify the technical issues related to recent mobile computing environment.

Module I: Introduction [6L]:

Evolution of different types of wireless communication devices; Effects of mobility of devices; Cellular mobile networks – mobility management (call setup, handoff, interoperability and internetworking), bandwidth management, energy management, security; Brief introduction about different generations of wireless communication technology – 1G, 2G, 3G, 4G, 5G.

Module II: Mobile Data Communication [5L]

Mobile Data Communication, WLANs (Wireless LANs) IEEE 802.11 standard, Bluetooth technology, Bluetooth Protocols, Ad hoc networks initialization, leader election, location identification, communication protocols, energy and security.

Module III: Mobility Management in Cellular Networks [4L]

Call setup in PLMN (location update, paging), GPRS, Call setup in mobile IP networks; Handoff management; Mobility models- random walk, random waypoint, map-based, group-based.

Module IV: Bandwidth Management in Cellular Mobile networks [3L]

Mathematical formulation of the channel assignment problem (CAP); CAP and generalized graph coloring; Benchmark instances; Lower bound on bandwidth.

Module V: Localization of Nodes in a Mobile Network [4L]

Different approaches, Indoor and outdoor localizations, LOS and NLOS signals, Outdoor localization techniques – triangulation (TOA-based, AOA- based), errors due to inaccuracies in coordinates of beacon nodes and in measurements.

Module VI: Message Communication in Ad Hoc Networks [6L]

Collision avoidance mechanism (different schemes for a deterministic transmission schedule), collision resolution mechanism – successive partitioning approach; Time slot assignment based on location information, Point-to-point routing in ad hoc networks – proactive, reactive and hybrid approaches, different protocols - DSDV, DSR, AODV, TORA, ZRP

Module VII: Energy-efficient Communication [3L]

Energy efficiency at various layers - Physical layer, MAC layer, Network layer, Application layer, performance analysis in noisy channel environment.

Module VIII: Secure Wireless Communication [4L]

Introduction-different types of attacks, internal attacks, external attacks; measures against attacks (authentication, intrusion detection, encryption); RC4 algorithm

Text books:

- 1) K. Sinha, S.Ghosh and B. P. Sinha, Wireless Networks and Mobile Computing. CRC Press : New York, 2015.

Recommended books:

- 1) Research articles published on secure wireless communication (authentication, mitigation of DoS, DDoS, eavesdropping) published in leading journals.
- 2) Mark Ciampa, Guide to Designing and Implementing wireless LANs, Thomson learning, Vikas Publishing House, 2001.

CO-PO Mapping

CO #	PO1	PO2	PO3	PO4	PO5	PO6	PO7	PO8	PO9	PO10	PO11	PO12	PSO1	PSO2	PSO3
CS801A.1	2	2	2	2	3	2	1	1	2	2	3	3	2	2	1
CS801A.2	2	3	3	3	3	1	1	1	2	2	3	3	2	2	2
CS801A.3	3	3	2	3	3	2	2	2	3	3	3	3	3	2	2
CS801A.4	3	3	2	2	2	1	1	1	1	1	2	3	2	1	1

CS801A. 5	3	3	3	3	3	2	2	2	3	3	3	3	3	2	2
--------------	---	---	---	---	---	---	---	---	---	---	---	---	---	---	---

Name of the Paper: Human computer Interaction

Paper Code: CS801B

Contact (Periods/Week):3L/Week

Credit Point: 3

No. of Lectures: 35

Prerequisite:

- Basic understanding of relevant psychological theories and approaches

Course Objective(s): The Student Should Be Made To:

- Learn The Foundations Of Human Computer Interaction
- Be Familiar With The Design Technologies For Individuals And Persons With Disabilities
- Be Aware Of Mobile HCI
- Learn The Guidelines For User Interface

Course Outcomes: Upon Completion Of The Course, The Student Should Be Able To:

CS801B.1Design Effective Dialog For HCI.

CS801B.2Design Effective HCI For Individuals And Persons With Disabilities.

CS801B.3Assess The Importance Of User Feedback.

CS801B.4Explain The HCI Implications For Designing Multimedia/ Ecommerce/ E-Learning Web Sites.

CS801B.5Develop Meaningful User Interface.

Module I : FOUNDATIONS OF HCI [7L]

The Human: I/O Channels – Memory – Reasoning And Problem Solving; The Computer: Devices – Memory – Processing And Networks; Interaction: Models – Frameworks – Ergonomics – Styles – Elements – Interactivity- Paradigms.

Module II : DESIGN & SOFTWARE PROCESS [7L]

Interactive Design Basics – Process – Scenarios – Navigation – Screen Design – Iteration And Prototyping. HCI In Software Process – Software Life Cycle – Usability Engineering – Prototyping In Practice – Design Rationale. Design Rules – Principles, Standards, Guidelines, Rules. Evaluation Techniques – Universal Design.

Name of the Paper: Cyber law and Security Policy

Paper Code: CS801C

Contact (Periods/Week): 3L/Week

Credit Point: 3

No. of Lectures: 35

Prerequisite:

- 26. Familiarity in computer Networking.
- 27. Basic concepts about network security.

Course Objective(s)

- To Enable Learner To Understand, Explore, And Acquire A Critical Understanding Cyber Law.
- To learn the basics of a Cyber security.
- To Develop Competencies For Dealing With Frauds And Deceptions (Confidence Tricks, Scams)

Course Outcomes

CS801C.1 Make Learner Conversant With the Social and Intellectual Property Issues Emerging From _Cyberspace.

CS801C.2 Give Learners In Depth Knowledge of Information Technology Act And Legal Frame Work of Right to Privacy, Data Security and Data Protection.

CS801C.3 Develop the understanding of relationship between commerce and cyberspace

CS801C.4 To be familiar with network security threats and countermeasures.

CS801C.5 To be familiar with advanced security issues and technologies.

Module – 1A: Introduction of Cybercrime: [7]

Cybercrime, Forgery, Hacking, Software Piracy, Computer Network intrusion
Jurisdiction to prescribe/Legislative Jurisdiction; Jurisdiction to adjudicate to enforce; Cyber
Jurisdiction in Civil, Criminal & International Cases.

Module – 1B: Category of Cybercrime: [5]

Criminals plan attacks, passive attack, Active attacks, cyberstalking. Unicitral Model Law,
Information Technology Act.

Module – 2: Cybercrime Mobile & Wireless devices: [8]

CS801C.5	3	2		3								1
-----------------	---	---	--	---	--	--	--	--	--	--	--	---

Name of the Paper: Parallel Computing

Paper Code: CS802A

Contact (Periods/Week):=3L/Week

Credit Point: 3

No. of Lectures: 35

Prerequisite:

- 31. Familiarity with Operating Systems
- 32. A solid background in Computer Organization and Architecture & Algorithm

Course Objective(s)

The objectives of this course are:

- To learn the basics of parallel system and how parallel computers work.
- To learn how to analyze the correct designs of parallel architectures, especially within the technological constraints.
- To prepare students for a career in designing the computer systems of the future.

Course Outcome(s)

On completion of the course students will be able to

CS802A.1:	Explain the range of requirements that modern parallel systems have to address.
CS802A 2:	Define the functionality that parallel systems must deliver to meet some need.
CS802A.3:	Articulate design tradeoffs inherent in large-scale parallel system design.
CS802A.4:	Demonstrate the potential run-time problems arising from the concurrent operation of many (possibly a dynamic number of) tasks in a parallel system.
CS802A.5:	Justify the presence of concurrency within the framework of a parallel system.

Module I (Introduction) (7L)

Concepts of pipelining and parallelism, Temporal vs. spatial parallelism, differences between distributed computing and parallel computing, loosely coupled vs. tightly coupled systems, Types of parallel architectures – Instruction vs. data (SIMD, MISD, MIMD) (Flynn’s

classification), Series vs. parallel (Feng's classification), Pipelining vs. parallelism (Haendler's classification). Performance measures – Speed-up factor, AT and AT^2 measures, Amdahl's law, Models of parallel computation – Parallel RAM (PRAM) model, (EREW, CREW, CRCW models), Interconnection network based model, Interrelationship among the performances under EREW, CREW and CRCW models.

Memory interleaving - S-access and C-access organization.

Concept of reservation table in multifunction static pipeline and minimum average latency.

Elementary concepts of data flow architecture.

Module II (Interconnection Networks) (9L)

Static interconnection networks – concept of network graph and the desirable features of a network graph in terms of node degree, diameter, fault-tolerance and bisection width, Different types of interconnection network - Crossbar, Clos, loop, star, wheel, double-loop, tree, mesh, torus, multi-mesh, mesh of trees, multi-mesh of trees, shuffle-exchange, pyramid, hypercube, butterfly, cube-connected cycles, Moebius network, De Bruijn network, OTIS architecture.

Dynamic interconnection networks – concept of blocking, non-blocking and re-arrangeable networks, Baseline, Omega and Benes networks.

Module III (Parallel Arithmetic) (10L)

Addition/Subtraction - Addition of two n-bit numbers in $O(\log n)$ time with $O(n \log n)$ logic gates using precarry addition, carry-propagation free addition in redundant binary number system.

Multiplication – Dadda's generalized multiplier, column compression technique, parallel algorithm for multiplying two n-bit signed integers in $O(\log n)$ time, parallel multiplication in redundant binary and quaternary number systems.

Division : $O(\log^2 n)$ division algorithm using repeated multiplications and additions.

Parallel algorithm for prefix sum computation on different architectures.

Matrix transpose : $O(n)$ algorithm on a mesh architecture, $O(\log n)$ algorithm on a shuffle-exchange network.

Matrix multiplication : parallel algorithms for multiplying two $n \times n$ matrices in $O(n^2)$, time, $O(n \log n)$ time, $O(n)$ time, $O(\log n)$ time and $O(1)$ time on appropriate parallel architectures, matrix by vector computation.

Module IV (Numerical Problems) (4L)

Solution of simultaneous linear equations: parallel algorithm based on Gauss-Jordan elimination, parallel algorithm based on Gauss-Seidel iteration.

Finding roots of a polynomial equation : parallel algorithms based on bisection method and Newton-Raphson method.

Module V (Sorting and Searching) (5L)

Odd-even transposition sort, sorting networks, 0-1 principle, Batcher's odd-even merge sort, Batcher's bitonic sort, sorting n^2 elements in $O(n)$ time on a 2-D mesh, brief discussion on sorting n^4 elements in $O(n)$ time on a multi-mesh. Parallel algorithms for searching.

Text books:

1. Design and Analysis of Parallel Algorithms- Selim G. Akl, Prentice Hall.

2. Computer Architecture and Parallel Processing – Kai Hwang and F. A. Briggs, McGraw-Hill.

Recommended books:

1. Parallel Computing –Theory and Practice -Michael J. Quinn. McGraw-Hill.
2. The Art of Computer Programming Vol. 3 (Sorting and Searching) – Donald E. Knuth, Addison-Wesley.

CO-PO Mapping:

CO #	PO1	PO2	PO3	PO4	PO5	PO6	PO7	PO8	PO9	PO10	PO11	PO12
CS802A.1	2	3	3	2	3		1		1	1		2
CS802A.2	3	2	3	3	2		1		1	1		2
CS802A.3	3	3	3	3	2		1		1	1		2
CS802A.4	2	3	3	3	3		1		1	1		2
CS802A.5	2	3	2	3	2		1		1	1		2
CS802A	3	3	3	3	3		1		1	1		2

Name of the Paper: Machine Learning

Paper Code: CS802B

Contact (Periods/Week): 3L/Week

Credit Point: 3

No. of Lectures: 35

Prerequisite:

1. Basic programming skills, Algorithm design.
2. Probability, Axioms of Probability, Conditional Probability, Bernoulli Distribution, Binomial Distribution, Multinomial Distribution, Uniform Distribution, Normal (Gaussian) Distribution, Chi-Square Distribution, t Distribution, F Distribution. Probability Distribution and Density Functions, Joint Distribution and Density Functions, Conditional Distributions, Bayes' Rule, Expectation, Variance, Weak Law of Large Numbers.
3. Linear Algebra; Convex Optimization ; Statistics; Calculus.

Course Objective(s)

CS802B.1 Be able to formulate machine learning problems corresponding to different applications.

CS802B.1 Understand a range of machine learning algorithms along with their strengths and weaknesses.

CS802B.1 Understand the basic theory underlying machine learning.

CS802B.1 Be able to apply machine learning algorithms to solve problems of moderate complexity.

CS802B.1 Be able to read current research papers and understand the issues raised by current research.

Course Outcomes

CS802B.1 Have a good understanding of the fundamental issues and challenges of machine learning: data, model selection, model complexity, etc.

CS802B.2 Have an understanding of the strengths and weaknesses of many popular machine learning approaches.

CS802B.3 Appreciate the underlying mathematical relationships within and across Machine Learning algorithms and the paradigms of supervised, un-supervised learning and reinforcement learning.

CS802B.4 Be able to design and implement various machine learning algorithms in a range of real-world applications.

Module – 1: Introduction [3L]

Applications and problems, learning scenarios, concepts of tasks (problems to be solved by machine learning), models (output of machine learning) and features (workhorses of machine learning).
geometric models, probabilistic models, logical models. [3L]

Module – 2 Classification Schemes [5L]

Binary classification, assessing and visualizing performance of classification, scoring and ranking, turning rankers into classifiers, class probability estimation. [3L]

Multiclass classification, multiclass scores and probabilities, regression, unsupervised and descriptive learning, predictive and descriptive clustering. [2L]

Module - 3: Various Models[15L]

Tree Models [3L]

Decision trees, ranking and probability estimation trees, tree learning as variance reduction, regression trees. [3L]

Rule Models [2L]

Learning ordered rule lists, learning unordered rule sets, descriptive rule learning, rule learning for subgroup discovery, association rule mining, first-order rule learning. [2L]

Linear Models [4L]

Least squares method, multivariate linear regression, regularized regression. [1L]

Perceptron, support vector machine, soft margin SVM, probabilities from linear classifiers, beyond linearity with kernel methods. [3L]

Distance-based Models [3L]

Nearest neighbour classification, distance[-based clustering, K-means algorithm, clustering around medoids. Hierarchical clustering. [3L]

Probabilistic Models [3L]

Normal distribution, probabilistic models for categorical data, naïve Bayes model for classification, probabilistic models with hidden variables, Gaussian mixture model, compression-based model. [3L]

Module - 4 : Features [4L]

Types of features, calculation on features, categorical, ordinal and quantitative features, structured features, thresholding and discretization, normalization and calibration, incomplete features, feature selection - matrix transformations and decompositions. [4L]

Module - 5 : Model Ensembles and Machine Learning Experiments [4L]

Model Ensembles [2L]

Bagging and random forests, boosted rule learning, mapping the ensemble landscape – bias, variance and margins, meta learning. [2L]

Machine Learning Experiments [2L]

What to measure, how to measure, how to interpret, interpretation of results over multiple data sets. [2L]

Module - 6 : More Selected Topics in Machine Learning [4L]

Support vector machines – separable and unseparable cases, primal optimization and dual optimization problems, kernel methods – positive definite symmetric kernels and negative definite symmetric kernels, kernel-based algorithms. [4L]

Text Book

- Peter Flach, Machine Learning. Cambridge University Press, 2012.

Reference Books

- M. Mohri, A. Rostamizadeh and A. Talwalkar, Foundations of Machine Learning, MIT Press, 2012.
- Kevin P. Murphy, Machine Learning : A Probabilistic Perspective. MIT Press, 2012.

CO-PO Mapping

CO	PO1	PO2	PO3	PO4	PO5	PO6	PO7	PO8	PO9	PO10	PO11	PO12
CS802B.1	3	2	3	2	3							2
CS802B.2		3	3	2								1
CS802B.3	3	3	2									2
CS802B.4			2	2	3							1

Name of the Paper: Real Time Operating System

Paper Code: CS802C

Contact (Periods/Week):=3L/Week

Credit Point: 3

No. of Lectures: 36

Prerequisite:

7. Programming and Data Structures
8. Operating Systems
9. Computer Architecture and Organization
10. Computer Communication
11. Database Systems

Course Objective(s)

1. Syllabus deals with issues in real time operating systems, importance of deadlines and concept of task scheduling.
2. Student will be able to understand and design real time operating systems which are backbone of embedded industry.

Course Outcome(s)

On completion of the course students will be able to

CS802C .1. Student will be able to summarize the issues in real time computing.

CS802C.2. Student will be able to explain and give examples of real time operating systems.

CS802C.3. Student will be able to solve scheduling problems and can apply them in real time applications in industry.

CS802C.4. Student will also be able to design an RTOS and will be able to interpret the feasibility of a task set to accomplish or not.

CS802C.5. Analyze the situation of fault occurrence and will be able to apply solutions accordingly.

Module I: Introduction to Real time systems 08L

Issues in real time computing (1L)

Structure of real time system (1L)

Need for RTOS (1L)

Task classes, Performance measures for real time system: Properties, traditional performance measures, performability, cost functions and hard deadlines, and Estimating program run times. (2L)

Introduction LINUX/ UNIX OS.(1L)

Module II: Embedded software and Task Scheduling 12L

Examples of embedded system (1L)

Characteristics and their typical hardware components, embedded software architectures (1L)

Scheduling algorithms: round robin, round robin with interrupts, function queue scheduling real time operating system selection (3L)

CPU scheduling algorithms: Rate monotonic, EDF, MLF.(2L)

Priority Scheduling, Priority Ceiling and Priority inheritance (2L)

Real time operating system: Tasks and task states, shared data and reentrancy semaphores and shared data, use of semaphores (2L)

Protecting shared data. (1L)

Module III: Features of Real Time Operating System 5L

Messages, queues , mailboxes , pipes , timer function , events, memory management

Interrupt basic system design using an RT (OS design principles, interrupt routines, task structures and priority.) (4L)

Case Studies: Vx Works and Micro OS-II.(1L)

Module IV: Real Time Databases 6L

Real time v/s general purpose databases, main memory databases, transaction priorities transaction aborts, concurrency control issues: pessimistic concurrency control and optimistic concurrency control, Disk scheduling algorithms.(6L)

Module V: Fault Tolerance Techniques 5 L

Causes of failure, Fault types(1L)

Fault detection , Fault and error containment (1L)

Redundancy: hardware redundancy, software redundancy, Time redundancy, information redundancy (1L)

Data diversity (1L)

Integrated failure handling (1L).

Text Books

3. Rajib Mall, "Real-Time Systems: Theory and Practice," Pearson, 2008.
4. Jane W. Liu, "Real-Time Systems" Pearson Education, 2001.

References

3. Alan C. Shaw, Real-Time Systems and Software, Wiley, 2001.
4. Philip Laplante, Real-Time Systems Design and Analysis, 2nd Edition, Prentice Hall of India.

CO-PO Mapping

CO	PO1	PO2	POP3	PO4	PO5	PO6	PO7	PO8	PO9	PO10	PO11	PO12
CS802C.1	3					1						2
CS802C.2	3	2	1									3
CS802C.3	2	3	2	2		2	2	2				3
CS802C.4	2	2	3	1	1	1						2
CS802C.5	1	3	1	1		1		2				3
CS802C	2	3	2	1	1	1	2	2				3

Name of the Paper: Advanced Computer Architecture

Paper Code: CS802D

Contact (Periods/Week):3L/Week

Credit Point: 3

No. of Lectures: 35

Prerequisite:

33. Familiarity with the functionalities of basic digital computer system
34. Fundamentals of Computer Architecture

Course Objective(s)

CS802D.1 To acquire the knowledge of parallelism and pipelining

CS802D.2 To develop knowledge of parallel processing

CS802D.3 To combine the concept and design techniques of interconnection network

CS802D.4 To acquire the knowledge of shared memory architecture

CS802D.5 To describe the fundamentals of embedded system architecture

Total :35 Lectures

Module – 1: Introduction to Advanced Computer Architectures [5L]

Different types of architectural classifications – instruction vs. data (SISD, SIMD, MISD, MIMD), serial vs. parallel, pipelining vs. parallelism; Pipelining: Definition, different types of pipelining, hazards in pipelining.

Concept of reservation tables, issue of multiple instructions with minimum average latency (MAL).

Module –2: Parallel Processing & ILP[8L]

RISC architecture, characteristics of RISC instruction set & RISC pipeline, its comparisons with CISC, necessity of using optimizing compilers with RISC architecture, Review of instruction-level parallelism-Super pipelining, Superscalar architecture, Diversified pipelines and out of order execution, VLIW architecture, Dataflow and Control Flow Architectures, Loop Parallelization

Module – 3: Interconnection Networks[13L]

Desirable properties of interconnection networks, static interconnection networks – path, cycle, double-loop, star, wheel, 2D mesh and its variants, multi-mesh, tree, shuffle-exchange, cube, cube-connected cycles

Dynamic interconnection networks: concepts of blocking, rearrangeable and blocking but rearrangeable networks, various types of multistage interconnection networks (MIN)- crossbar, clos, baseline, omega, Benes.

Module -4: Shared Memory Architecture [4L]

Fundamentals of UMA, NUMA, NORMA, COMA architectures, Performance measurement for parallel architectures –Amadahl's law, Gustafson's law

Module – 5: Embedded System Architecture [5L]

Definition, Example, Classification of Embedded system, Embedded System Design Issues: Hardware issues (Processor, Memory, Peripherals) ,Software issues (Programming Languages, Time Criticality, RTOS)

Recommended Books

Text Books

- J. L. Hennessey and D. A. Patterson: Computer Architecture: A Quantitative Approach, 5th edition, Morgan Kaufmann, 2012.
- K. Hwang and F. A. Briggs: Computer Architecture and Parallel Processing, Tata McGraw Hill, New Delhi.

Reference Books

- Tse-yun Feng, A Survey of Interconnection Networks, IEEE, 1981.
- Selim G. Akl, The Design and Analysis of Parallel Algorithms, Prentice-Hall, 1989.
- Raj Kamal, Embedded Systems Architectures Programming and Design, Second Edition The MacGraw-Hill(for Embedded System)

CO-PO Mapping

CO	PO1	PO2	PO3	PO4	PO5	PO6	PO7	PO8	PO9	PO10	PO11	PO12
CS802D.1	3											
CS802D.2	3	3	1									
CS802D.3	3	3	3	2	3							
CS802D.4	3	3	3	2	3							
CS802D.5	3	2	2	2	2							
CS802D	3	3	2	2	3							